

DIEMAKING  
AND DIE DESIGN



Class \_\_\_\_\_

Book \_\_\_\_\_

Copyright N<sup>o</sup> \_\_\_\_\_

**COPYRIGHT DEPOSIT**









DIEMAKING AND  
DIE DESIGN





# DIEMAKING AND DIE DESIGN

A TREATISE ON THE DESIGN AND PRACTICAL APPLICATION OF DIFFERENT CLASSES OF DIES FOR BLANKING, BENDING, FORMING AND DRAWING SHEET-METAL PARTS, INCLUDING MODERN DIEMAKING PRACTICE AND FUNDAMENTAL PRINCIPLES OF DIE CONSTRUCTION

COMPILED AND EDITED  
By FRANKLIN D. JONES

ASSOCIATE EDITOR OF MACHINERY  
AUTHOR OF "TURNING AND BORING," "PLANING  
AND MILLING," "GAGING TOOLS AND  
METHODS," ETC.

---

*FIRST EDITION*

---

NEW YORK  
THE INDUSTRIAL PRESS  
LONDON: THE MACHINERY PUBLISHING CO., LTD.

1915

1-253  
-20

COPYRIGHT, 1915  
BY  
THE INDUSTRIAL PRESS  
NEW YORK

*Composition and Electrotyping by  
F. H. Gilson Company, Boston, U.S.A.*

10950  
© CIA-10964

no. 1

15-30034

## PREFACE

---

Dies are now used so extensively and have made possible such wonderful results in the rapid production of sheet-metal parts, that die construction has become a subject of great importance to everyone interested in modern manufacturing methods. This treatise deals with the two essential elements in the production of dies; namely, the designing of various types, and the methods of constructing them. It also includes a great deal of information on the practical application of different classes of dies.

In any kind of machine or tool manufacture there is always some variation in the methods employed in different machine shops and tool-rooms for doing the same general class of work, and diemakers are not an exception to this universal rule. In fact, there is probably a greater difference in the methods of diemakers than is found in any other single branch of tool or machine manufacture, because of the almost endless variety of dies which has often made it necessary for diemakers to devise their own methods of procedure. Therefore, this treatise contains information which, to some extent, represents the practice and experience of different diemakers, and while, in some cases, there may be other and, perhaps, better methods for accomplishing the same results, an effort has been made to deal with fundamental principles and present information that is not only reliable, but of practical value to those engaged in this kind of work.

Throughout the book various types of dies are described to illustrate practical designs. All of these designs are special in the sense that they are intended for producing some particular part, and, at first thought, it might seem useless to study the details of a die which in all probability will not exactly be duplicated within the experience of any one toolmaker or diemaker.

It should be remembered, however, that the best way to obtain a broad, general knowledge of die construction is by studying as many different designs as possible in order to become familiar with those features which have proved successful in actual practice. Incidentally, many of the tools illustrated are ingenious types and represent, in a general way, what has been accomplished in the art of constructing dies.

Readers of mechanical literature are familiar with MACHINERY'S twenty-five cent Reference Books, of which one hundred and forty-one different titles have been published during the past seven years. As many subjects cannot be covered adequately in all their phases in books of this size, and in response to a demand for more comprehensive and detailed treatments of the more important mechanical subjects, it has been deemed advisable to publish a number of larger volumes, of which this is one. This treatise includes part of MACHINERY'S Reference Books Nos. 126, 131 and 132, and it is believed to be unusually complete in its treatment of the more important branches of die work.

F. D. J.

NEW YORK, *August*, 1915.

# CONTENTS

## CHAPTER I

### CLASSES OF DIES FOR SHEET-METAL WORK

	PAGES
Plain Blanking Dies — Follow or Progressive Dies — Gang or Multiple Dies — Compound Dies — Perforating Dies — Shaving or Trimming Dies — Burnishing Dies — Embossing Dies — Drawing Dies, including the Combination, Double-action, and Triple-action Types — Redrawing Dies — Forming Dies — Bending Dies — Curling Dies — The Sub-press Type of Die — Swaging Dies. . . . .	1-24

## CHAPTER II

### DIEMAKING METHODS AND BLANKING DIE CONSTRUCTION

Kinds of Steel Used for Die Work — Value of Annealing — Laying Out Blanking Dies — Laying Out Dies for Washers — Templets for Blanking Dies — How a Templet is Used — Methods of Machining Blanking Dies — Die Shaping, Slotting and Milling Machines — Filing Dies by Hand — Die-filing Machine — Clearance between Punches and Dies for Different Thicknesses of Stock — Angular Die Clearance — Fitting the Punch to the Die — Methods of Holding Punches — Types of Piercing Punches — Locating Punches in Punchholder — Shear of Punches and Dies — Hardening Punches and Dies — Reworking Worn Dies — Stripping Stock from Punch — Cam-actuated Strippers — Pilots or Guide Pins for Punches — Punch Troubles and Remedies — Various Types of Stop-pins for Controlling Feeding Movement of Stock — Position of Stop-pin Relative to Hole in Die — Various Types of Die-beds or Bolsters — Examples of Blanking Dies	25-108
--	--------

## CHAPTER III

## DRAWING AND FORMING DIES

PAGES

Selecting Type of Drawing Die — Depth of First Drawing Operation — Diameter of First Drawing Die — Diameter Reductions for Redrawing — Formation of Wrinkles — Shapes of Drawing Edges — Ironing or Thinning the Stock — How to Determine the Blank Diameter — Blank Diameter Formulas for Various Shapes of Drawn Shells — Formation of Air Pockets in Dies — Lubricants for Drawing — Examples of Drawing Die Design — Drawing Cartridge Cases — Drawing Brass Shrapnel Cases — Multiple Drawing Die of Indexing Type — Dies for Rectangular Drawing — Blank-holder Pressure Compensating Attachment — Laying Out Rectangular Dies — Shape of Blanks for Rectangular Work — Blanks for Drawing Elliptic Shapes — Trimming Drawn Rectangular Parts — Miscellaneous Points on Drawing and Forming Die Construction.....	109-187
---	---------

## CHAPTER IV

## BENDING AND CURLING DIES

Simple Types of Bending Dies — Die for Making Four Bends — Die for Making Five Bends — Staple Bending Die — Combination Bending and Twisting Die — Compound Bending Die — Curling Dies for Hinges — Curling Dies for Tin Buckets — Special Curling Die — Wiring Dies for Small Brass Covers.....	188-211
--	---------

## CHAPTER V

## CONSTRUCTION AND USE OF SUB-PRESS DIES

Advantages of the Sub-press — Typical Sub-press Die Construction — Sub-press Die for Blanking and Forming Copper Cups — Large Sub-press Dies — Sectional Sub-press Die — Making Sub-press Dies — Sub-press Die of the Four-post Type — Stripping Blanks that Adhere to Punches and Ejectors — Separating Sub-press Die Blanks from Scrap...	212-243
---	---------

## CHAPTER VI

## SECTIONAL PUNCH AND DIE CONSTRUCTION

	PAGES
Advantages of the Sectional Type — Examples of Sectional Die Construction — Sectional Die for Square Washers — Sectional Die for Linotype Type-bar Plates — Making Sectional Die Parts — Grinding Die Sections — Special Chucks for Holding Die and Punch Sections — Milling Segments for Pole-piece Sectional Punches . . . . .	244-264

## CHAPTER VII

AUTOMATIC FEEDING AND EJECTING MECHANISMS  
FOR PRESSES

The Single-roll Feed — Automatic Release for Feed-rolls — Rack and Pinion Double-roll Feed — Push Feed — Slide Feed — Ratchet Dial Feed — Friction Dial Feed — Friction Dial and Push Feed — Friction Dial and Reciprocating Feed — Chute and Hopper Feed — Feed Chute for Drawing Press — Mechanically-operated Knockout — Ejecting Press Work with Air Blast . . . . .	265-286
--	---------

## CHAPTER VIII

TOOLS FOR PERFORATING CYLINDRICAL AND  
CONICAL WORK

Construction of Perforating Dies — Perforating Shells of Tapered and Irregular Shapes — Methods of Rotating Shell to be Perforated — Lay-out of a Perforating Die — Making the Punch for a Perforating Die — The Stripper of a Perforating Die — Spiral Perforating — Tools for Perforating Brass Shells . . . . .	287-313
--	---------

## CHAPTER IX

## MULTIPLE PLUNGER PRESS AND ITS TOOLS

	PAGES
Arrangement of a Typical Multiple Plunger Press — Transfer Slide and Auxiliary Mechanism — Operation of the Transfer Slide — Methods of Holding the Punches and Dies — Tools for Multiple Plunger Presses — Examples of Shell Work Done on Multiple Plunger Press — Strippers for Mul- tiple Plunger Press Work — Examples of Flanged Shell Work — Drawing Operation on Eight-plunger Press. . . . .	314-329



# DIEMAKING AND DIE DESIGN

---

## CHAPTER I

### CLASSES OF DIES FOR SHEET-METAL WORK

It is rather difficult to classify and give proper definitions of the many designs and types of dies used on power presses for the production of sheet-metal work. While there are, of course, some general classes into which all dies may be divided, the various types overlap in many cases, so that one is often in doubt as to the proper classification of dies which combine the features of different types. All dies may, in the first place, be divided into two general classes, *viz.*, cutting dies, and shaping dies. Cutting dies include all designs which simply cut or punch flat blanks or pieces of the required outline from the stock fed into the press. On the other hand, shaping dies include all those which change the form of the material from its original flat condition. This second main division, however, often includes features which are common to the first; that is, some dies are a combination of cutting and shaping dies, the blank to be shaped or formed being first cut out to the required outline from the stock and then shaped to the desired form.

The main classes of dies, as will be seen, are based on the *use* of the die. The first of the classes mentioned, cutting dies, may, however, be further sub-divided according to the construction of the various types of dies in this class. We then distinguish between four distinct types, *viz.*, plain blanking dies, follow dies, multiple or gang dies, and compound dies. The second main division of shaping dies cannot be sub-divided according to the construction of the dies in the same manner as the cutting dies. Owing to the great variety of work performed in shaping dies, the designs vary too greatly for a classification on the basis of

constructional features. They may, however, be divided into sub-classes arranged according to the general uses to which they are put; thus, there are bending dies, embossing and forming dies, drawing dies, and curling dies.

These different classes of cutting and shaping dies are briefly described in the following to indicate, in a general way, the constructional features and practical application of each type. In succeeding chapters more detailed descriptions are given, and a variety of the more important classes of dies are illustrated.

**Plain Blanking Dies.** — Plain blanking dies are the simplest of all types of dies and are used to cut out plain, flat pieces of

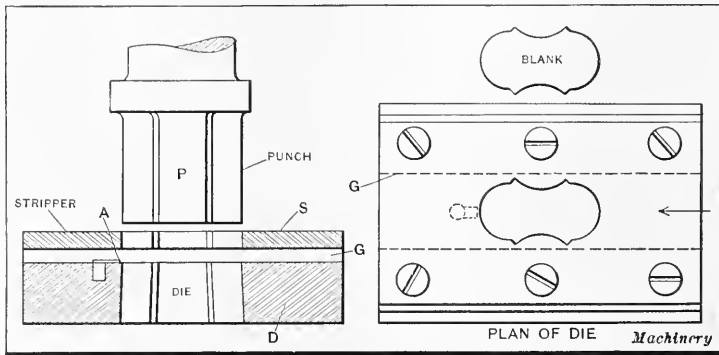

Fig. 1. Plain Blanking Punch and Die

stock having, in general, no perforations. This type of die consists of a die-block *D* (see Fig. 1), which has an opening that conforms to the shape of the part to be cut or blanked out; a punch block *P*, which accurately fits the opening in the die-block and, by a shearing action, does the cutting as it descends into the die-block opening; and a stripper plate *S*, which strips the stock off of the punch block as the latter ascends. The opening in the stripper plate conforms to the shape of the punch and is either slightly larger to provide a little clearance, or close fitting to steady the punch. Between the stripper plate and die-block there is a guide *G*, which serves to keep the stock in alignment with the die opening as it is fed along. This guide (which may be formed by planing a channel on the under side of the stripper) is made so that the space between the die and strip-

per will be somewhat greater than the thickness of the stock used; in fact, this space must be sufficient to allow the stock to move along easily even when the surface is made somewhat irregular by the operation of the punch. In a simple die of this kind, the spacing of the holes punched in the stock is commonly controlled by some form of stop-pin *A*, which engages the edge of each successive opening; for instance, after a blank is cut out, the operator feeds the stock along until the opening thus made comes against the stop, thus locating the stock for cutting out the next blank.

**Follow Dies.** — Follow dies are used for work which must be cut from the stock to the required shape and, at the same time,

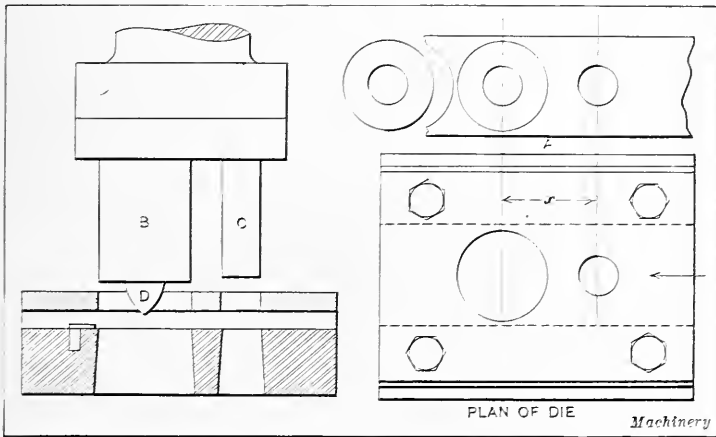

Fig. 2. Follow Die for Piercing and Blanking Washer

be provided with holes or perforations. The principle of the follow die is that while one part of the die punches the hole in the stock, another part blanks out the work at a place where, at a former stroke, a hole or opening was punched, so that a completed article results from each stroke of the press; in reality, however, two separate operations have been performed, the operation being a progressive one in which the holes are first pierced after which the stock moves along until the pierced section is in line with the blanking punch. A simple form of follow die designed for cutting washers is shown in Fig. 2. The

blanking punch is located at *B* and the piercing punch at *C*. As the stock is fed along in the direction indicated by the arrow (see plan view of die) the hole in the washer is first made by the piercing punch; then, on the next stroke of the press, the stock is fed a distance  $x$  so that the pierced hole is directly under the blanking punch, which cuts out the completed washer. The action of the two punches relative to the stock is indicated at *A* which illustrates a small section of the stock. As both punches operate at the same time, obviously, a completed washer is cut out at each stroke of the press. Of course, if the washers were required in large quantities, the die would be designed to cut out two or more washers at each stroke of the press.

Many dies of this type have a pilot *D* on the end of the blanking punch which engages the pierced hole after the stock has been approximately located by a stop-pin, or otherwise. In this way, the stock is located so that the outside is cut concentric with the hole, within a small limit of variation. When the blanking punch is without a pilot, the accuracy of the work is dependent upon the accuracy with which the stock is fed through the die. For instance, if an operator should fail to push the stock against the stop-pin, the cut made by the blanking punch would not be correctly located relative to the pierced hole. Hence, pilots are commonly used, although they have one objectionable feature: If the punch should descend when the pierced hole was not under the pilot, a broken punch might result, unless a spring-supported pilot, which could recede, were employed. Even when a pilot is used, extremely accurate work cannot be produced in a follow die because there must be a slight clearance between the pilot and the pierced hole and this causes more or less error; moreover, when using a die of the design illustrated in Fig. 2, the stock is distorted or wrinkled to some extent by the action of the punches because the stock lies loosely between the stripper and the die. To avoid this trouble, some blanking dies have a spring-supported stripper which is attached to the punch and presses against the stock while the punches are at work. Some punch presses are also equipped with a cam-actuated stripper.

Follow dies are also called "progressive" or "tandem" dies. They are also frequently termed "gang" dies, although it is doubtful if the latter name is correct. (See Gang or Multiple Dies.) By referring to Fig. 2, it will be seen that the blanking punch is slightly longer than the piercing punch. This is done in order that the pilot may engage the hole in the stock and locate it before the piercing punch comes into action.

**Gang or Multiple Dies.** — When large numbers of blanks are required, multiple or gang dies are sometimes used. These dies have a number of duplicate punches with similar openings in the die-block and cut as many blanks as there are punches, at each stroke of the press. Fig. 3 illustrates a simple form of

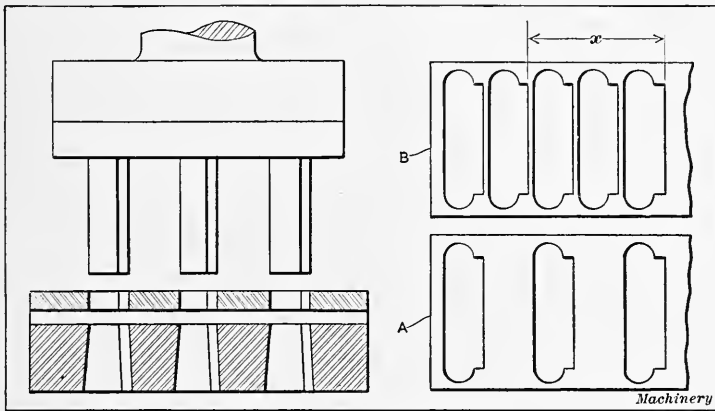

Fig. 3. Gang or Multiple Die

gang or multiple die. As will be seen, there are, in this case, three blanking punches. At the first stroke of the press, the stock is blanked out as at *A*; then, by feeding it a distance  $x$  for each stroke, the blank will be cut as at *B*. As will be noted, the punches in this case are located twice the center-to-center distance between the openings cut in the stock, instead of being close together. This is done because it would not be practicable to have the openings in the die-block as close as they should be in order to blank out the stock economically, since there would not be metal enough between the die openings to insure sufficient strength. The term "gang die" is often applied

to a follow die; this usage is generally conceded to be incorrect, however, as the word "gang," as used in mechanics, ordinarily means a combination of similar tools so arranged as to act simultaneously for producing duplicate parts.

**Compound Dies.** — Compound dies differ from plain blanking and follow dies in that the simple punch and die elements are not separated but are combined so that both the upper and the low members contain what corresponds to a punch and die, as well as suitable stripper plates or ejectors. The faces of

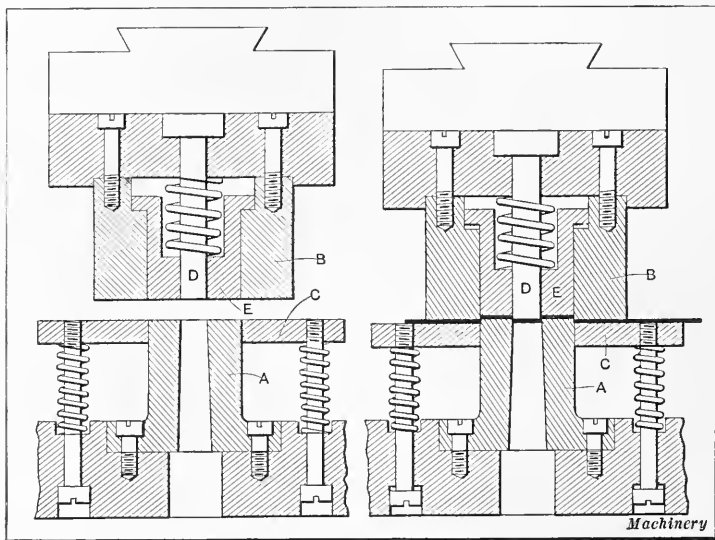

Fig. 4. Compound Die which Pierces and Blanks Simultaneously

the punches, dies, and stripper plates are normally held at about the same level and the strippers are spring supported so as to recede when the stock is being cut. A compound die produces more accurate work than the types previously referred to for the reason that all operations are carried out simultaneously at one stroke, while the stock is firmly held between the spring supported stripper plates and opposing die-faces. A compound die is shown in Fig. 4. The operation of this die is as follows: The upper die descends and depresses stripper plate C. As the downward movement continues, the blank is cut from the stock

by members *A* and *B* and, at the same time, a central hole is pierced by punch *D*, as indicated by the right-hand view. The blank is forced out of the upper die *B* by ejector *E* as the ram ascends, and the stripper plate *C* also pushes the stock up off of the die-block *A*. The scrap punched from the hole falls through the opening in die-block *A*, which has clearance to provide a free passage-way. The blank is returned to the strip of stock, from which it can easily be removed.

Inasmuch as the piercing and blanking operations are performed at the same time, very accurate work can be obtained in a die of the compound type. Such delicate parts as armed wheels or gear punchings for clocks, meters, etc., are examples of the work that can be done in this form of die. Such parts are made complete, including the arm spaces, center hole, and holes in the arms or rim if desired, with one stroke of the press. The stock from the arm spaces and other holes is forced down through the die while the blank is returned to the strip from which it was punched. The punchings obtained in a compound die are flat, accurate as to size, shape, and position of holes, and can be made very rapidly. One method of using a die of the compound type is to fit the punch into the socket of the slide of the press, and, after aligning, to clamp the die-block to the bolster plate. This method is fairly satisfactory for simple punches and dies, but, with more complicated designs, the aligning is more difficult and it is also more necessary that it should be as perfect as possible; hence a better arrangement is needed and this has been found in the sub-press method (see The Sub-press).

**Perforating Dies.** — The dies used for punching large numbers of holes or perforations in sheet metal, for producing strainers, sifting devices, etc., and also the dies used for cutting ornamental shapes around the edges of lamp-burner shells, etc., are commonly known as perforating dies. The type of die used for perforating sheet stock is in reality a multiple or gang die, but as a general rule the work of a perforating die differs from a gang die in that it is used to punch a large number of holes, whereas a gang or multiple die, as these names are ordinarily

applied, means the type that is used to blank out a number of duplicate parts. There may be exceptions, however, to this general classification. Some perforating dies, such as are used for perforating sheet metal or other materials, have hundreds of punches which are arranged in rows and operate simultaneously.

**Shaving Dies.**—Dies of this class are sometimes used for finishing the edges of comparatively thick blanks which have been cut out in a regular blanking die. A blanking die used for cutting heavy stock must have a certain amount of clearance between the punch and die opening, the amount depending

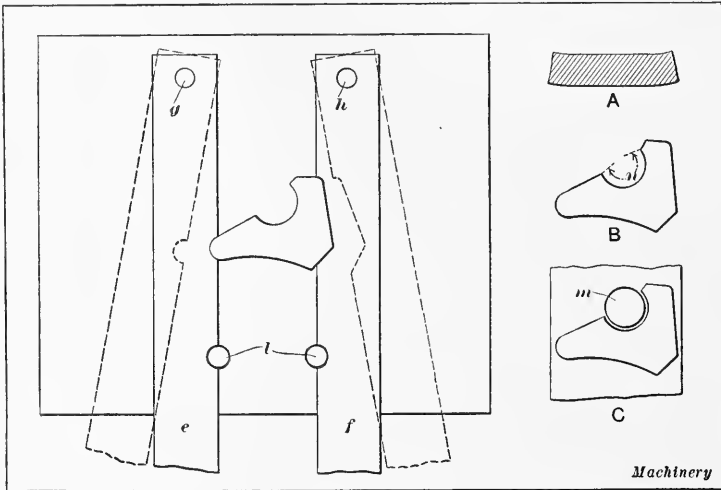

Fig. 5. Simple Design of Shaving or Trimming Die

upon the thickness and kind of material. As the result of this clearance (which lessens the danger of breaking the punch and reduces the pressure required for the punching operation), the edges of thick blanks are somewhat rough and also tapering, as shown at *A*, Fig. 5. To secure smooth square edges, shaving dies are used in some cases. The plan view to the left illustrates a simple form of shaving die designed for finishing the blank, shown at *B*. This die has an opening which conforms to the shape required for the finished blank and it is equipped with two arms *e* and *f* which are pivoted at *g* and *h*, respectively.



These arms are notched to receive and locate the rough blank directly over the die opening. In the operation of the die, the arms are swung outward as indicated by the dotted lines, and are then closed in on the blank and against the locating pins *l*. The press is then tripped and the punch (which fits the hole in the die) descends and pushes the blank through the die, thus shaving and finishing the rough edges.

Shaving dies do not always have pivoted arms to locate or form a "nest" for the blank, but are sometimes provided with movable plates which are held in position by springs and have beveled edges so that they are forced outward slightly each time a blank is pushed downward through the die. Spring pins are also used to form a nest in shaving dies. The advantage of movable arms or a nest supported laterally by springs is that they not only facilitate inserting and removing the blank, but prevent the chips from jamming between the blank and the nest, as they tend to do with a nest of the fixed type. The pivoted arms or movable plates also facilitate cleaning away the chips from the top of the die face. Incidentally, it is very important, when making a blanking die for parts which are to be pushed through a shaving die afterwards, to have the right amount of play or clearance between the blanking punch and die. When there is not the right amount of clearance, the edges of the blank will be too ragged and irregular or, as the diemaker would express it, the blank is not cut with a "clean break"; the result is that these irregularities make it impossible to secure a smooth edge by means of the shaving die.

Sometimes the entire edge or contour of a blank does not need to be finished but it is necessary to have part of the surface smooth. In such a case, the effect of shaving may be obtained in the blanking die, and without a separate shaving operation, by piercing a hole adjacent to the edge where a good finish is required. The principle of this method is illustrated at *C*, Fig. 5. Assuming that it is only necessary to have the curved edge *n* (see sketch *B*) smooth, hole *m* should be pierced in the stock adjacent to edge *n*, prior to the blanking operation, by means of a piercing punch. The result is that, when the

part is blanked, edge  $n$  is subjected to a shaving action, owing to the thin strip of metal at this point. The amount of metal left for shaving should be equal to about 10 per cent of the stock thickness for mild steel. Dies designed on this principle are described in Chapter II.

**Burnishing Dies.** — When an exceptionally good finish or polish is required, blanks which have been trimmed in a shaving die are pushed through what is known as a burnishing die. Such a die has an opening which tapers slightly inward toward the bottom, and it is finished very smooth, so that, when the blank is forced through by the punch, the metal around the

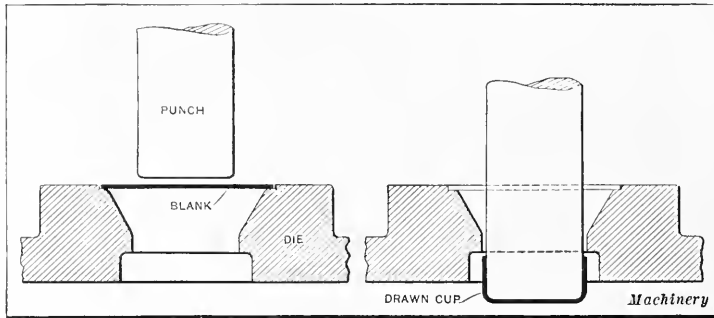

Fig. 6. Simple Type of Drawing Die

edges is compressed and polished. Naturally, the degree of finish on the blanks will depend largely upon the finish of the burnishing surface of the die.

**Embossing Dies.** — An embossing die is used to form raised letters or an ornamental design, in relief, upon the surface of the work. An embossing die differs from a forming die in that the projections or designs made by it are comparatively small or shallow, and usually in the nature of relief work upon a surface, whereas a forming die gives the required shape to the work. The formation of lettered inscriptions, symbols, and decorative designs on all kinds of sheet-metal boxes and cans is done by embossing dies. A simple form of embossing die is one used for producing the circular ridges on the heads of tin cans, etc. Such a die would have one or more annular grooves and the punch would have annular ridges of corresponding size for

forcing the metal into the die grooves. Embossing is commonly done in a die designed to cut, draw, and emboss the blank in one operation. An embossing die of this kind may be either a combination, a double-action, or a triple-action type, depending upon the nature of the work and the kind of press available.

**Drawing Dies.** — Dies of this class are used for drawing parts from flat stock into cylindrical and various other shapes. There are several different classes of drawing dies, including plain drawing dies, combination dies, double-action dies, and triple-action dies. A very simple design of plain drawing die is shown in Fig. 6. The blank to be drawn is first cut in an ordinary blanking die; it is then laid in the drawing die, being located centrally with the die opening by an annular recess in the die face. After the clutch of the press is engaged, the punch descends and forces the flat blank through the die opening (as indicated by the right-hand view), thus forming it into a cup or shell of cylindrical shape. As the punch ascends, the drawn part is stripped from its end. This stripping may be caused by the contact of the upper edge of the cup with the lower edge of the die; some dies are also equipped with pivoted dogs or fingers which tilt downward as the punch descends and then swing in above the edge of the cup, thus stripping it off of the ascending punch. This form of die (commonly known as a "push-through die") is inexpensive as compared with some other designs and is often used for drawing operations, especially when the stock or metal is quite thick. Such dies are not adapted to drawing stock thinner than, say,  $\frac{3}{8}$  or  $\frac{1}{16}$  inch.

Most first-operation dies, or those for drawing parts from flat blanks, are equipped with a blank-holder which presses against the outer part of the blank while the punch forces it through the die opening. The advantage of using a blank-holder is that when the blank is being drawn radially inward, if it is confined between the top surface of the die in a blank-holder or "pressure pad," wrinkles cannot readily form.

The method of confining the blank and drawing it, or, in other words, the design of the die, depends upon the conditions,

such as the number of parts to be drawn, the amount or depth of the draw, type of drawing press available, etc. A simple and inexpensive form of drawing die of the type having a blank-holder is shown in Fig. 7. This die also draws a blank which has been cut out in another die. The blank to be drawn is placed in a recess in the die face, and when the press ram descends (after the clutch has been tripped by the operator) the blank-holder *D* first engages the blank; then, as the downward movement continues, the rubber pressure-pad *F* is compressed so that the blank is held firmly by the blank-holder while the

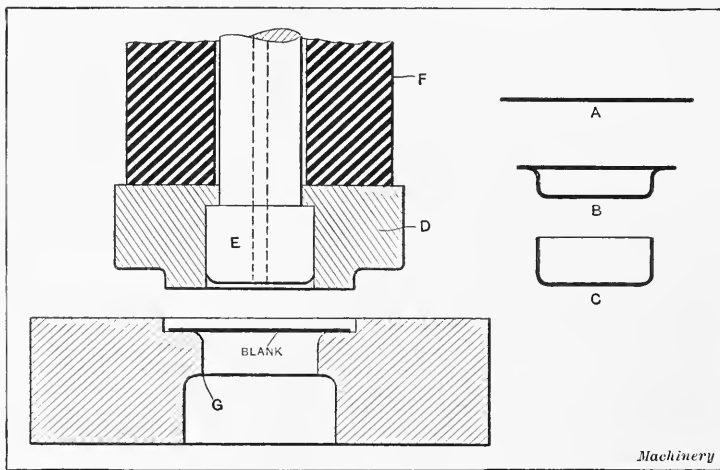

Fig. 7. Plain Drawing Die equipped with Blank-holder

drawing punch *E* forces it through the cylindrical opening in the die. In this way, a cylindrical cup is formed from the flat blank, as indicated at *A*, *B*, and *C*, which show the blank, the half-drawn cup, and the finished cup. The cup is stripped from the ascending drawing punch by coming into contact with the lower edge *G* of the die opening. If a smaller and deeper cup is required, additional drawing operations in separate redrawing dies are necessary. Some dies of the type shown in Fig. 7, instead of having a rubber buffer, are equipped with a strong spring for operating the blank-holder; rubber, however, is preferable.

**Combination Drawing Dies.** — The combination type of die is one in which a blanking die and either a drawing or forming die are combined so that the blank is cut out and drawn or formed to shape in one stroke of the press. Owing to the construction, a combination die can be used in a single-action press, or one having a single slide. A typical combination die of the blanking and drawing type is illustrated in Fig. 8. Its operation is as follows: When punch *F* descends and enters die *E*,

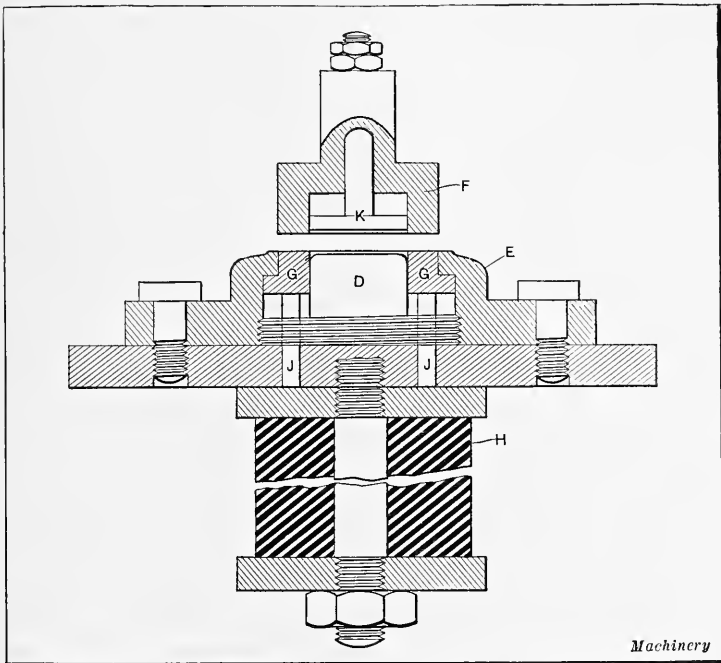

Fig. 8. Combination Drawing Die for Use in Single-action Press

it cuts out the blank and forces the blank-holder *G* downward against the tension of the rubber pressure attachment *H*, the blank-holder being supported upon the connecting pins *J*. As the downward movement continues, the blank is drawn to a cylindrical shape between the bore of the blanking punch *F* and the drawing punch *D*.

When the ram of the press ascends, the shell is stripped from punch *D* by the blank-holder *G*; the shell is also ejected from

the blanking-punch *F* by the "knockout" *K*. The stem of this knockout extends up through the punch and has either a cross-pin or nuts at its upper end to hold it in place. The usual method of operating the knockout is to force it down positively. This may be done by means of a stationary arm or bar which extends through an elongated slot in the slide. When the punch ascends the upper end of the knockout stem strikes this stationary arm and in this way the knockout is forced down, thus ejecting the drawn cup from the inside of the punch. Another arrangement is as follows: A bar of rectangular section extends laterally through an elongated slot in the slide and engages the top of the knockout stem. When the punch ascends, the outer ends of this cross-bar strike set-screws so that the knockout is forced down. These set-screws are adjusted according to the stroke of the press. A rubber pressure attachment is generally applied to dies of this type instead of a spring, because the rubber is more durable and gives a more uniform pressure.

In most cases, articles made in combination dies are in the form of shallow cups, etc., such as can tops and bottoms, pail bottoms and a variety of similar parts which frequently are not over  $\frac{1}{4}$  inch in depth. Dies of this class are also used for deeper articles, such as boxes and covers for blacking, salve, tobacco, etc., with depths up to about one inch. Most combination dies are so arranged that the finished article is automatically pushed out from the dies by the action of a stripper, as previously described; with a press set on an incline, the finished work will, therefore, slide back by gravity.

Combination dies that are to be used for blanking and forming parts of either conical or irregular shapes are frequently made on the same principle as the one just described. Punch *D*, however, is shaped to conform to the shape to which the cup is to be drawn and on the under side of knockout *K* there is a cavity or pocket which fits over the punch and forms a seat into which the work is forced. When the die is in use, the blank, after being cut, is drawn and formed between the face of knockout *K* and the punch. If the part is not too deep, it can be

blanked and drawn in one operation in a die designed in this way.

**Double-action Dies.**— These dies are known as a double-action type because the blanking and drawing punches have independent movements which are derived from the two slides of a double-action press; hence, the name of the die, in this case, indicates the type of press in which it is used. A double-action die of the “push-through” type is illustrated at *A* in Fig. 9. The combined blanking punch and blank-holder *c* is operated by the outer slide of the double-action press and moves slightly in advance of the drawing punch *d*, which is actuated by the inner slide. The outer slide is so arranged that, after making its stroke, it stops during about one-quarter of a revolution of the

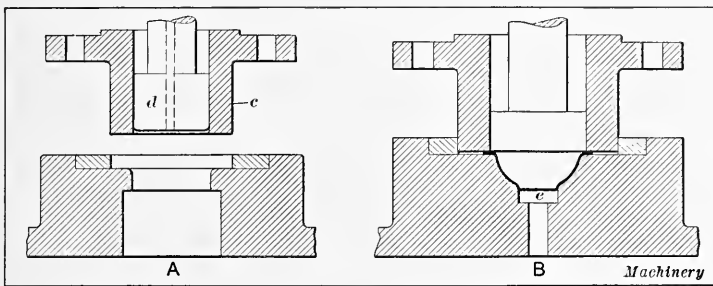

Fig. 9. Double-action Drawing Dies of “Push-through” and “Solid-bottom” Types

crankshaft. The blank, after having been sheared from the sheet by the outer edge of punch *c*, is held between the end of punch *c* and the seat in the die, during the dwell of the outer slide. While the blank is thus held under a pressure which can be regulated to suit the special requirements of each case, the drawing punch *d* continues its downward movement, thus drawing the metal from between *c* and the die, into the form of a cylindrical cup. The drawing punch is so timed or adjusted that it will not reach the blank until the latter is subjected to sufficient pressure by the blank-holder for the drawing operation.

While this type of die requires a double-action press, it is very much simpler in construction than the combination die illustrated in Fig. 8, which, as previously mentioned, is used in

a press of the single-action type. The design of die shown at *A*, Fig. 9, is suitable for cylindrical articles which can be pushed through the die; hence, it is sometimes called a "push-through" cutting and drawing die, to distinguish it from the solid bottom type shown at *B*, which may be used for producing a cup of the shape illustrated. As will be seen, both the drawing punch and die conform to the shape of the part to be drawn. This type of die is equipped with knockout or "push-out plate" *e* at the bottom of the die, which rises on the upstroke of the press and lifts the drawn part from its seat in the die. This push-out plate, which is also called a "knockout," may be either spring

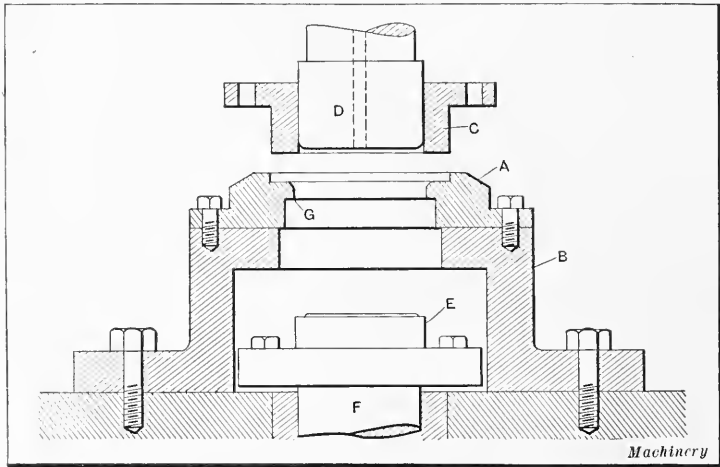

Fig. 10. Triple-action Die for Blanking, Drawing, and Embossing

actuated or positively operated from beneath (as in the case of the die illustrated) by connection with the press.

**Triple-action Die.** — A triple-action die, as the name implies, is one having three independent movements. This class of dies is used to produce articles requiring three operations, such as cutting or blanking, drawing, and stamping or embossing. They are frequently used in preference to a solid bottom, double-action die of the type shown at *B*, Fig. 8, because they deliver the finished part *below* the drawing die instead of pushing it up, thus enabling the operator to feed continuously and without waiting for each piece to be ejected before blanking for another



operation. A triple-action die is illustrated in Fig. 10. The cutting and drawing die *A* is mounted on a raised bolster *B*; *C* is the blank-holder and cutting punch; *D*, the drawing and embossing punch; and *E*, the embossing die.

In the operation of this die, the blank is cut by punch *C*, which acts as a blank-holder, while the cup is drawn by punch *D*. As the drawing punch continues to descend, it carries the drawn cup downward until its lower surface engages the embossing die *E*. The latter is mounted on plunger *F*, and on its up-stroke imparts to the work the required impression, which may be a fancy design, lettering, etc. On the up-stroke of the punch,

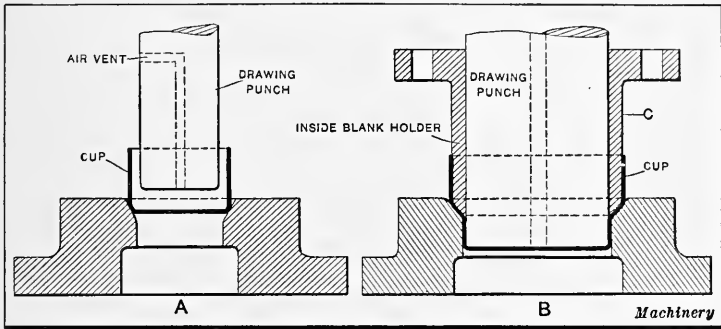

Fig. 11. (A) Plain Redrawing Die. (B) Redrawing Die with Inside Blank-holder

the finished article is stripped by edge *G*, and, if the press is set on an incline, the work slides back by gravity beneath the raised bolster *B* into a box. With a die of this type, drawn and embossed articles can be produced as rapidly as plain covers in "push-through" dies. Triple-action dies are especially adapted for such work as drawing and embossing lettered covers for blacking boxes, baking powder cans, covers for lard pails and also for articles such as seamless sardine boxes, etc.

**Redrawing Dies.** — After cups have been drawn in either a plain or double-acting drawing die, what are known as redrawing dies are often used to reduce the diameters of these comparatively shallow cups and at the same time increase the depth or length, thus forming a shell. Some redrawing dies do not differ essentially from an ordinary plain drawing die, as will

be seen by referring to sketch *A*, Fig. 11. In this particular design, the cup is located in the die by an annular recess above the drawing surface and it is reduced in diameter and lengthened by simply being pushed through the die. There is, of course, a limit to the amount of reduction which can be obtained in a single drawing operation, and when a long shell is required, a series of redrawing dies are necessary, the steps or reductions in diameter being varied according to the thickness and quality of the metal being drawn. This subject is treated more fully in Chapter III.

Sketch *B*, Fig. 11, shows another type of redrawing die, which is especially adapted for drawing large, cylindrical parts when considerable reduction is required and when the stock is thin and liable to wrinkle. In this case, the cup to be redrawn is held by an inside blank-holder *C* as it passes between the lower beveled edge of the holder and the die, as the drawing punch descends. A double-action press must be used for a die of this kind, one slide operating the blank-holder and the other the drawing punch. The blank-holder presses against the cup and prevents the formation of wrinkles while the punch draws it into a deeper shape of less diameter. These dies, especially when used for large work, are frequently made of cast iron, treated in such a manner as to give a very dense and uniform texture to the metal at the working surfaces. Sometimes a steel ring is set into a cast-iron holder to form the drawing part of the die, and the blank-holder is made of a steel casting, which adds considerable to the durability of the tools. For articles which have to be very accurate in diameter, a hard steel sizing punch and die are sometimes used after the last redrawing operation.

**Forming Dies.** — Forming dies are a type in which a blank is formed into a hollow shape by simply being pushed into a cavity of the required shape in the die, or a previously drawn cup is given a different shape by compressing it between a punch and die which conform to the shape desired. Drawing dies are also used for the formation of cup-shaped articles, but the drawing process differs from forming in that the stock is usually

confined between two surfaces so that when drawn radially inward from between them, no wrinkles can form. To define the difference between the two types in another way, forming dies shape the metal by compressing and bending it, whereas, drawing dies so act upon a flat blank or a previously drawn cup, that the shape is changed by drawing the metal as the punch moves relative to the die or *vice versa*.

**Bending Dies.** — Dies of this class are designed for bending sheet metal or wire parts into various shapes which are usually irregular and are produced either by pushing the stock into cavities or depressions of corresponding shape in the die or by

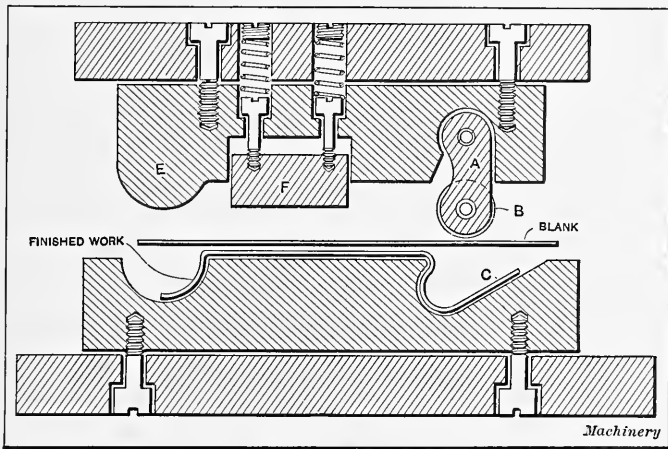

Fig. 12. Bending Die

the action of auxiliary attachments such as slides, etc., which are operated as the punch descends. A simple form of bending die would be one having an upper part or punch shaped to correspond with a depression in the die face; such a bending die is sometimes employed for bending flat, sheet-metal plates into an irregular shape. When the material to be bent is elastic or springy, the die must be made to allow for this, or so that the part is bent slightly beyond the required shape or angle to compensate for the backward spring when the pressure is released. Determining this allowance is, of course, a matter of experiment.

An interesting design of bending die is shown in Fig. 12. As

will be seen, a swinging arm is pivoted at one end of the punch; this arm carries a steel roller *B*. When the punch descends, this roller bends the stock down into the die at *C*. When the downward travel of the roller is checked by the die, the arm *A* swings to the left and continues to move in this direction until the roller has formed the work into the die, as shown by the lower finished part. The left-hand end of the work is formed between the die and the extension *E* of the punch. Before the punch has reached the end of its downward travel, the gripper *F* engages the work and holds it in position through the tension of the two springs shown in the illustration. This prevents any move-

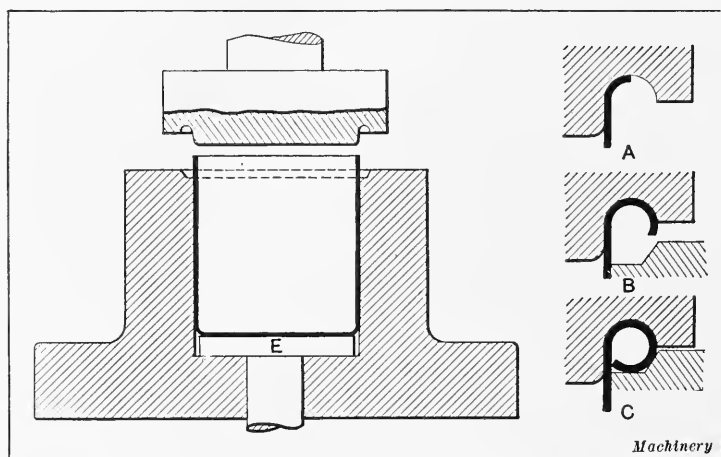

Fig. 13. Die for Curling Edges of Cylindrical Parts

ment of the blank during the final stages of the bending operation.

**Curling Dies.** — The dies used to form circular beads around the edge of drawn cylindrical parts, and for such work as forming cylindrical tubes or other shapes from flat stock, are commonly known as curling dies. A curling die for beading the upper edge of a drawn cup is shown in Fig. 13. The curling punch has a central projection which fits into the work, and it is provided with a semi-circular groove which engages the edge of the cup as the punch descends. This causes the edge to curl over as indicated by the detailed sectional views, *A*, *B*, and *C*. The curling process is usually applied to thin metals less than

$\frac{1}{32}$  inch thick, such as sheet tin, sheet iron, and sometimes brass or copper. Some curling dies are equipped with an ejector or "knockout" *E*, especially if the work is of such a shape that it cannot readily be removed by hand.

The diameter of the bead that can be formed in a curling die must not be too large in proportion to the diameter of the work, and is ordinarily not over  $\frac{3}{16}$  inch for tin plate and sheet iron. This limitation as to diameter is due to the fact that, as the edge is forced outward by the curling punch, the circumference increases and the metal is stretched; hence, if the diameter of the bead is too large, this excessive stretching of the material causes it to crack in a radial direction at numerous points around the edge. If the metal is well annealed, naturally a comparatively large bead can be formed. Curling dies, especially when used for forming a bead or curl around a wire at the edge of tin-ware, etc., are commonly referred to as wiring dies. Some wiring dies are practically the same as the one just described, excepting that the die has a floating spring-supported ring upon which the wire ring rests. As the punch descends, the curl is formed around the wire, enclosing it. Curling or wiring dies for tapering parts such as milk pans, etc., have a curling punch which is composed of six or eight segments instead of being solid, so that it can contract when entering the tapered part.

**The Sub-press.** — A sub-press cannot be defined as a special class of die, but merely as a principle on which different kinds of dies may be worked. The sub-press principle is simply that the upper and lower portions of the die are combined into one self-contained unit so arranged as to always hold the upper and lower members in exact alignment with each other. A common form of sub-press construction is shown in Fig. 14. It consists of a base *B* which is clamped to the press, a frame or "barrel" *A* fitted to the base, and a plunger *C* which slides vertically in an adjustable babbitt bearing. The plunger head or "button" *D* is connected to the press slide by what is known as a "hook." The latter is merely a slotted member which engages the annular groove seen at the upper end of the plunger.

The compound type of die is commonly used in a sub-press.

The upper die is located in the plunger and the lower die in the base. This sub-press construction permits of a high degree of accuracy as it insures an accurate alignment of the various members of the die. Sub-presses are largely used for producing such parts as small wheels and gears and other delicate parts for clocks, watches, meters, time recorders, and other similar pieces which must be made with great accuracy and uniformity. Although, in some cases, one sub-press can be made to take

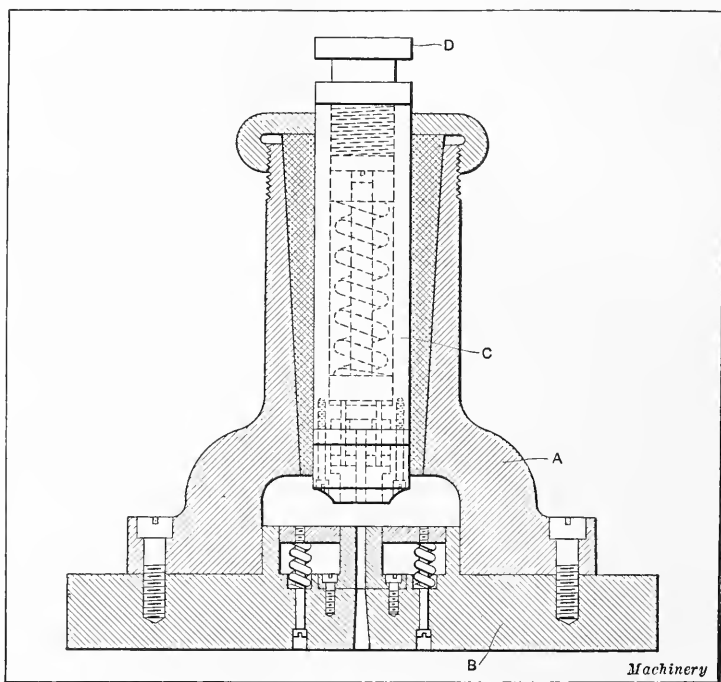

Fig. 14. Sub-press for Aligning and Guiding Upper and Lower Members of Compound Dies

several sets of punches and dies, it is customary, and generally advisable, to have a separate sub-press for each set, as one of the advantages gained in using the sub-press is in being able to quickly change from one die to another; when separate sub-presses are used this can be done by simply loosening the clamps, changing the presses and re-clamping. In addition to this advantage, there is no time wasted in aligning the punches and

dies; moreover, the danger of shearing the punch or die, as a result of careless alignment, is entirely eliminated.

Another advantage of the sub-press, dependent in part on the accuracy of alignment provided, and the corresponding accuracy in fitting which can be given to the cutting edges, is that the work is remarkably free from fins and burrs. A consideration of the action of the press will show that there is practically no chance for burrs to form in a piece even where they would in an ordinary blanking die. It is, of course, necessary for the die to descend until the punch has all but entered it, if clean work is to be produced. There is a slight difference in the practice of

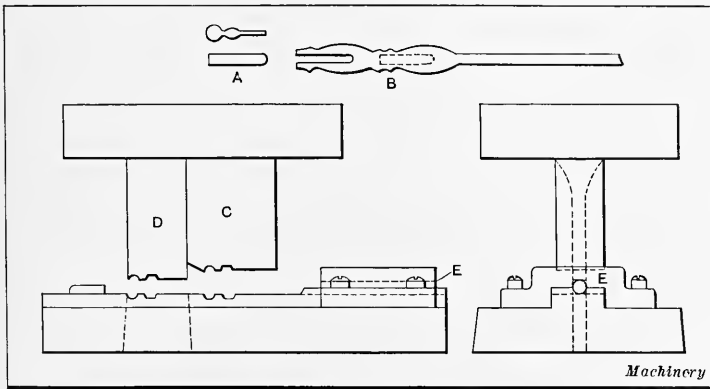

Fig. 15. Swaging and Blanking Die

different operators in this respect, although this difference in practice would be expressed in the dimensions of only 0.002 or 0.003 inch, perhaps. Some of them adjust the stroke so that the die does not quite meet the punch. Others prefer to have them meet and even enter by very slight amount. The only objection to the use of sub-presses is the extra cost, and this is often more apparent than real. The difference in cost is more noticeable in a simple, low-priced die than in a compound die, and, in fact, in the latter case it often occurs that a complicated die can be made with less expense by using a sub-press than by any other method.

Some dies which operate on the sub-press principle differ from the construction shown in Fig. 14, in that the upper and lower

die members are held in alignment by guide-rods which are fastened to the lower die and extend through holes in the upper die. This construction is common for large dies, the usual method being to have four of these guide-rods, one at each corner of the die. Dies of this kind are sometimes called "pillar dies."

**Swaging Dies.** — Swaging dies are a type in which parts are formed to the required shape by compressing the metal so that the impressions in the punch and die faces are reproduced upon the work; in other words, instead of shaping the metal by cutting, bending, or drawing, it is formed by compression. The pressure required for swaging is relatively high because it must be sufficient to cause the metal to flow into the punch and die cavities or depressions. A combined swaging and blanking die of simple form is shown in Fig. 15, which is used for making the small part illustrated at *A*. These parts are formed by feeding an annealed brass wire through the die, swaging to the required form, and then blanking it. At *B* is shown the end of the wire after the swaging and blanking punches have done their work. The swaging punch is illustrated at *C*, while *D* is the punch which cuts and forces the blank through the die. The wire is fed through a hole in guide *E* which keeps it in proper alignment with the working faces of both die and punch. The dotted lines shown on the swaged end at *B* indicate where the next piece *A* will be cut from the stock by the blanking punch *D*. A stripper (not shown) removes the scrap from the blanking punch. The pieces after coming from the die are tumbled to remove all fins, and then drilled.



## CHAPTER II

### DIEMAKING METHODS AND BLANKING DIE CONSTRUCTION

When constructing a die, the degree of accuracy with which it is made and the general finish will depend somewhat upon the amount of work that it will be required to do or the number of pieces to be produced. When this number is comparatively small, the most inexpensive die that will do the work properly should be made. Dies of this class are known as "emergency dies," as they are quickly made and are not constructed to withstand long and continuous usage. When, however, a die is to be used incessantly for a long period, or, perhaps, until it is worn out through use, the materials used and the quality of the workmanship should be of the highest possible grade and every detail brought as near perfection as possible. Of the many different kinds of dies in use, the blanking die is the most common type. The reason for this is that almost all work that requires the use of various other kinds of dies either has its beginning with the blanking die, or is cut from the flat stock after it is completed by other dies which may or may not be combined with the blanking die. In making a blanking die, there are a few essential points to be taken into consideration, among which are the following:

1. Use good tool steel of a sufficient length, width, and thickness to enable the die to withstand the work for which it is intended.

2. In laying out the die, care should be taken that as little of the stock as possible is left over, as waste, in cutting out the blanks.

3. Be sure not only that the die has the proper amount of clearance but also that the clearance is filed or machined *straight*, so as to enable the blanks to drop through readily.

4. In working out the die, machine out as much as possible to avoid excessive filing.

**Kind of Steel Used for Die Work.** — For most work the stock used in making punches and dies should be a good quality of tool steel. A die that has cost from ten to a hundred dollars for labor is as liable to crack when hardening as though the same steel had been made into any other form of tool; and in fact its shape and irregular thickness of stock at various points, together with numerous sharp corners that are liable to be present, make a tool that requires extreme care in handling when hardening. A good grade of tool steel, free from harmful impurities, is less liable to crack than an inferior grade, and the slight difference in cost is offset many times by the cost of labor in the die construction. This does not necessarily mean that a *high-priced* steel must be used for this class of work; simply a *good* quality of steel, low in percentage of those impurities which cause trouble when the steel is hardened. When we speak of good, reliable steel, we do not necessarily mean high-priced steel.

In all shop operations true economy should always be practiced, and many times this may be done by a saving of tool steel. In the construction of some dies a saving may be effected by making the body of cast iron and inserting bushings of tool steel; then if at any time the dies become worn they can be replaced by simply making new bushings, and if ordinary care is taken, the holes will be concentric and consequently the proper distance apart, so there will be no necessity of altering the location of the punches, as might be the case if a die made of a solid piece was hardened.

Some diemakers, when making irregular-shaped punches that are to cut thin stock, make them of machine steel and case-harden them. Soft steel, casehardened, does not change its form as much as tool steel, and even if the punch does change a trifle, the interior is soft and can be readily forced back to position. The outside being hard, the punch will wear nearly as long as one made from tool steel, for practically the only wear on a punch is when passing through the stock. For thin brass the punch works well when made of tool steel and left soft, and

when worn badly the punch can be peened on the face enough to upset it and then be sheared into the die.

**Value of Annealing.** — Many diemakers overlook the importance of first roughing a die nearly to size and then carefully annealing it. There are internal strains set up in the bar of steel during its manufacture which are sure to cause distortion of the die or tool unless these strains are removed before the work is brought to its finished size. Some steel may be free from strains, but there is no way of determining beforehand whether the steel has “settled” or not; therefore, to guard against distortion, the careful diemaker will not take chances, but will anneal the piece after it has been roughed out, because annealing relieves these internal strains.

The following test illustrates the value of annealing before finishing: Four pieces of tool steel were cut from the same bar and the same amount of stock was removed from each piece, finishing them all over to exactly the same dimensions. They were then marked *A*, *B*, *C*, and *D*. Pieces *A* and *B* were annealed after roughing, but pieces *C* and *D* were machined to size. The pyrometer was used to insure heating all the pieces to the same temperature of 1400 degrees F. The bath was clean water with a temperature of 68 degrees F. The pieces were heated separately in a muffle furnace and were allowed to remain in the bath exactly one minute, in each case. The result of this comparative test was as follows: The pieces *A* and *B* were slightly distorted, but the pieces *C* and *D* were distorted to such an extent that they were useless.

**Laying Out Blanking Dies.** — A most important point for the diemaker to bear in mind in making blanking dies for odd shapes is to lay them out so that the minimum amount of metal will be converted into scrap. In fact, hardly too much stress can be laid upon this one point alone, as it is an easy matter to waste a considerable percentage of the stock by lay-outs which may appear to be fairly economical. In the following, the object will be to point out by actual examples how stock can be saved which may be converted into scrap, if the diemaker is not constantly watching out for possible economies.

Beginning with a simple illustration, it sometimes happens that by laying out the dies so that the blanks are cut from the strip at an angle instead of at right angles to the edge of the stock, a considerable economy of metal can be effected. As will be seen by referring to Fig. 1, the angular location permits the use of narrower stock and materially reduces the amount of scrap metal. By comparing the upper and lower views, the saving in metal by diagonal blanking is apparent, as it is not only possible to use a much narrower strip of stock, but more

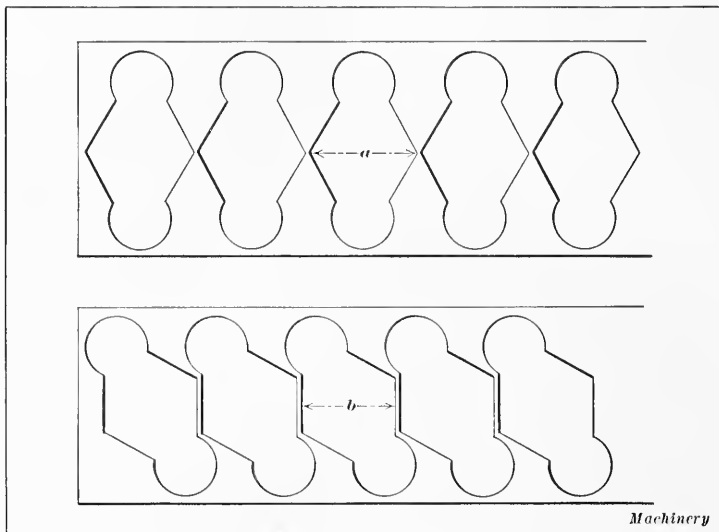

Fig. 1. Illustration of the Saving of Metal effected by Cutting the Blanks Diagonally from the Stock

blanks can also be obtained from a given length, as will be understood by noting the difference between the dimensions  $a$  and  $b$ . When thousands of blanks are to be produced, the saving in metal that is effected is considerable. The most economical lay-out can often be determined easily and quickly by cutting out a few paper templets and arranging them in various ways until the best method of blanking is ascertained.

When the shape of the blanks is such that there would, unavoidably, be a considerable amount of metal between the punched holes, the stock can, at times, be cut to a better ad-

vantage by so locating the stop- or gage-pin that sufficient metal is left between the holes to permit the strip being turned around and again passed through the press. If a large number of blanks are to be made, however, a double blanking die would be preferable.

An example of stock which is passed through the die twice is shown in Fig. 2. The upper view shows the stock after the

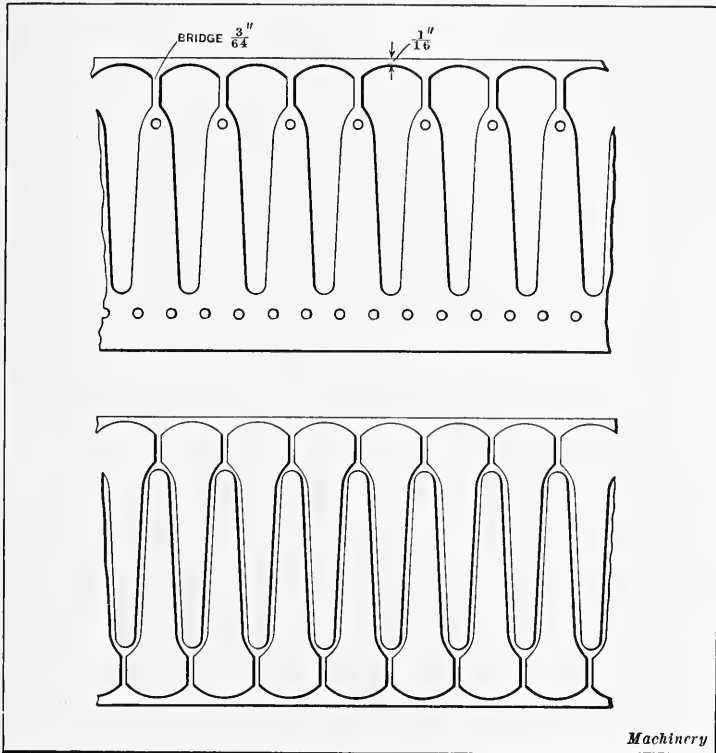

Fig. 2. (Upper View) Stock that is passed Once through Blanking and Piercing Die. (Lower View) Stock after the Second Passage through the Die

first passage and the lower view the scrap after the second passage. The lay-out of the blanking die for this operation is shown in Fig. 3. Each blank is pierced with three small holes as the plan view of the die indicates. Besides cutting and piercing the blank when the stock is run through the first time, the three small holes for the blanks to be cut out during the

second passage are also pierced, as the upper view, Fig. 2, shows. This is done for the reason that when the metal is run through the second time, the pierced holes serve as a guide in locating the stock and prevent the cutting of "half blanks" by "running in," or, in other words, the liability of cutting imperfect blanks by punching into that part of the metal from which blanks have already been cut. This guiding action is effected by three pilot pins in the blanking punch which engage the three pierced holes

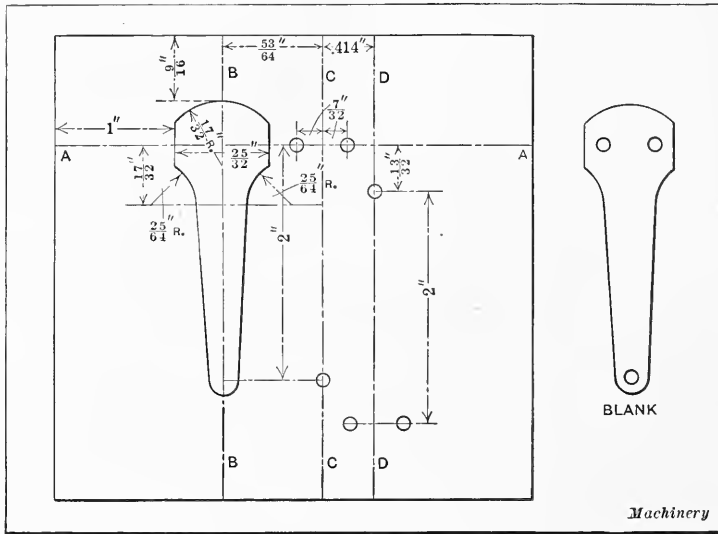

Fig. 3. Lay-out of Die for Blanking and Piercing Stock as Illustrated in Fig. 2

made when the strip was run through the first time. The pilot pins engaging with the pierced holes cause the second lot of blanks to be cut centrally with the holes, and also to be accurately centered between the portions of stock from which the blanks have already been cut. When this die is in use, the metal is run through in the usual way from right to left until half of the required amount of blanks is cut, after which the piercing punches for the holes are taken out and the metal is run through again and the other half of the required amount of blanks is cut.

In laying out this die, which is done after the manner shown in Fig. 3, the line A-A is used as the center-line for the upper

piercing holes and the line  $B-B$  as the center-line of the blanking part of the die. The line  $C-C$  is the center-line that marks the center of the next blank to be cut and is laid out  $\frac{5}{6}\frac{3}{4}$  inch from the line  $B-B$ . This dimension is fixed by the fact that the widest part of the blank is  $\frac{2}{3}\frac{5}{2}$  inch, and the bridge between the blanks is  $\frac{3}{6}\frac{1}{4}$  inch, the sum of which equals the distance from center to center of adjacent blanks. The line  $D-D$  is the center-line for the blank which is cut when the metal is run through the second time, and is made at  $0.414$  inch or one-half of  $\frac{5}{6}\frac{3}{4}$  from

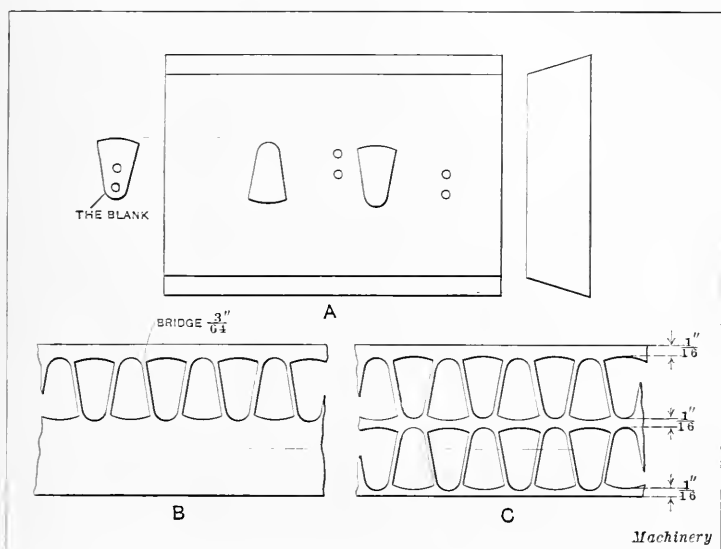

Fig. 4. Double Blanking and Piercing Die—Appearance of Stock that is passed through the Die

the line  $C-C$ , inasmuch as the blanks cut at the second passage of the stock are midway between those cut the first time the stock goes through the die.

At  $A$  in Fig. 4 is shown a double die for blanking and piercing brass stock, producing the shape shown in the sketch at the left; it is laid out so as to save as much of the metal as is practically possible without added expense so far as the operation of blanking and piercing is concerned. By referring to sketches  $B$  and  $C$ , it can be seen that the strip of metal from which the blanks are cut is run through a second time for reasons that will

be given. One reason is that wider metal can be used by doing this, which in itself is a saving so far as the cost of metal is concerned. Wide brass can be bought at a lower price per pound than narrow brass. The other reason is that a strip of metal  $\frac{1}{16}$  inch wide and as long as the entire length of the strip is saved on every strip that is run through. If narrow metal were used, there would be waste of  $\frac{1}{8}$  inch of metal (*i.e.*,  $\frac{1}{16}$  inch on each side) of every strip run through, and on two strips from which

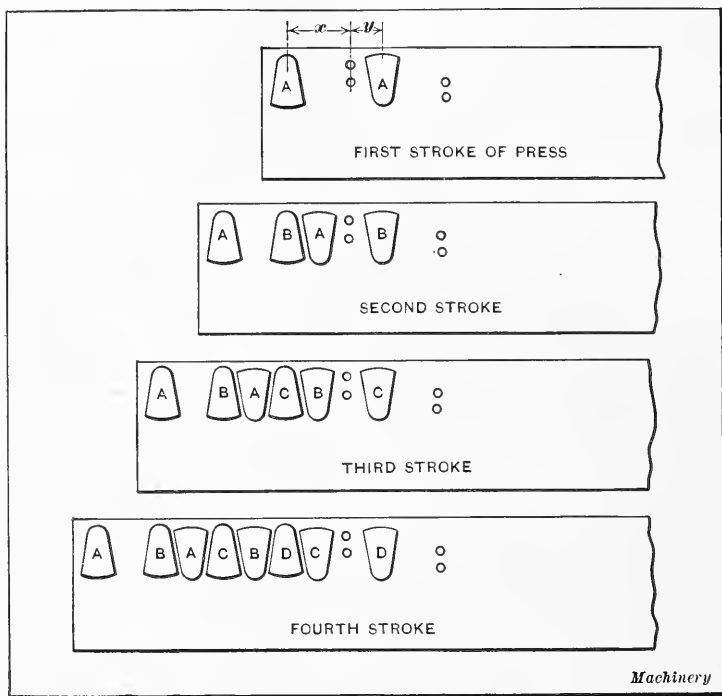

Fig. 5. Diagrams Illustrating Progressive Action of Double Die shown in Fig. 4

no more blanks could be cut than from the wider strip shown at C, there would be waste of  $\frac{1}{4}$  inch of metal. On the other hand, by using wide metal and running it through the die twice, the waste would be only  $\frac{3}{16}$  inch, as indicated at C.

To fully understand the manner in which the metal is gradually worked up after each stroke of the press, short sections are shown in Fig. 5. At the first stroke four holes are pierced and two



plain blanks *A*, having no holes, are cut out. At the second stroke there are also four holes pierced and the two blanks *B*, for which the holes were pierced at the previous stroke, are cut. At the third and fourth strokes the holes begin to match in with each other, as shown, so that when the metal is run through it will look like the strip shown at *B*, Fig. 4. It should be borne in mind that four holes are pierced and two blanks are cut at each stroke of the press; also that the metal is fed after

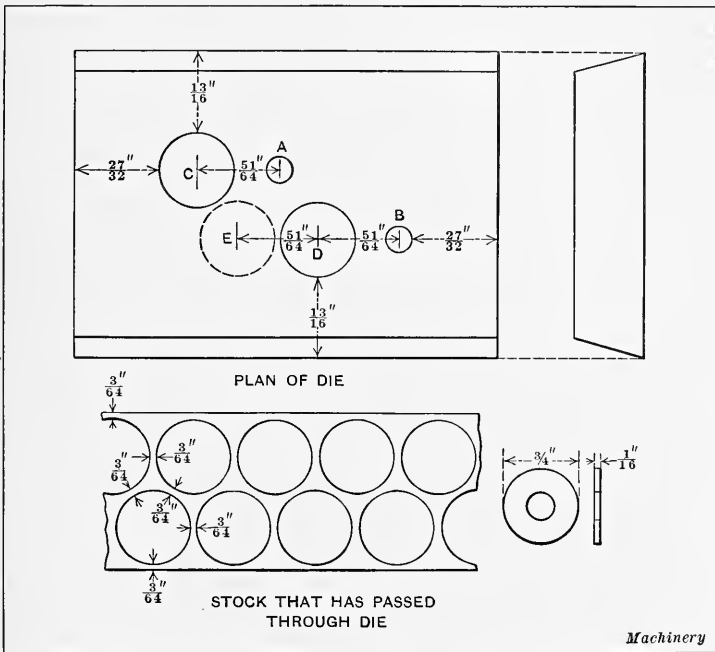

Fig. 6. Die for Piercing and Blanking Two Washers Simultaneously

each stroke a distance  $x$  equal to the distance from the center of the leading blanking punch to the center of the first set of piercing punches, as indicated in the strip marked "first stroke." In this particular case the feeding movement  $x$  equals  $2\frac{3}{2}$  inch, and the die is so laid out that the distance  $y$  equals one-half the feeding movement or  $\frac{2}{6}\frac{5}{4}$  inch.

**Laying Out Dies for Washers.** — To lay out a single washer die is a very easy matter, but to lay out a die for cutting two or

more washers at one time, so as to cut the greatest amount of blanks from the least amount of stock, is not understood as it should be. In laying out a washer die for blanking two or more washers at one time, one of the main points to be remembered is that all the holes from which the blanking and piercing are done must be laid out in an exact relation to each other, so as to eliminate the possibility of "running in," *i.e.*, cutting imperfect or half blanks by cutting into that part of the metal from which blanks have already been cut. The required amount of blanks must also be considered, for it sometimes happens that

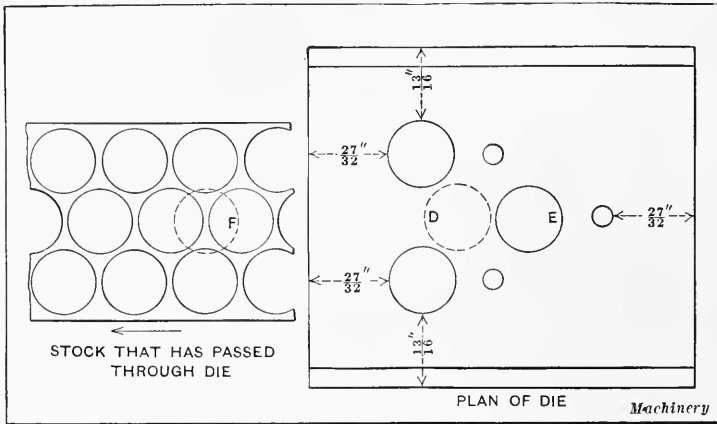

Fig. 7. Die for Piercing and Blanking Three Washers Simultaneously

the amount wanted does not warrant the making of a die that will cut more than one at a time.

Fig. 6 shows how a die is laid out for blanking and piercing two washers at one time, so as to utilize as much of the metal as possible. As shown, the  $\frac{3}{4}$ -inch holes marked *C* and *D* are the blanking part of the die, while the  $\frac{1}{4}$ -inch holes *A* and *B* are for the piercing punches. The distance between the center of *C* and *A* is  $\frac{5}{6}\frac{1}{4}$  inch, as is also the distance between *D* and *B*. By referring to that part of the illustration which shows a section of the stock after it has been run through the die, it will be seen that there is a narrow margin of  $\frac{3}{6}\frac{1}{4}$  inch of metal, known as "the bridge," between the holes. In laying out the die this margin must be taken into consideration, when determining the

center-to-center distance; thus, diameter of washer to be cut plus bridge equals distance from center of piercing punch to center of blanking punch. For example,  $\frac{3}{4} + \frac{3}{64} = \frac{51}{64}$ . The dotted circle on the plan view of the die shows that the die is laid out so that one washer is skipped in running the metal through at the start. The holes are located in this way in order to make the die a substantial and strong one. It can very readily be seen that if the circle *E* were the blanking part instead of *D*, the die would be a frail one, and would not be strong enough for the work for which it is intended. Another important point in laying out a die of this kind is to lay it out central, or so that when it is keyed in position ready for use in the center of the die-bed, it will not have to be shifted to the right or left side in order to make it line up with the punch. Incidentally, the punch plate, which holds the blanking and piercing punches in position, should also be laid out central.

Fig. 7 shows the lay-out for blanking and piercing three washers at one time. A section of the stock after it has been run through this die is shown to the left in the illustration. As will be seen, the holes match in very close together and very little stock is left in the form of scrap; moreover, the holes are "staggered" instead of being in a straight line across the width of the sheet. This is done in order to save metal; the dotted circle *F* is merely drawn to show that wider metal would have to be used if the holes were in a straight line.

The plan of a die for blanking and piercing eight washers at one time is shown to the right in Fig. 8. The holes which are numbered are for blanking and those which are lettered are for piercing the holes in the washers. This die is laid out similarly to the one shown in Fig. 7, with the exception that there is provision for eight blanks instead of for three. A section of stock after it has been run through this die is shown to the left. To give a better idea as to how the blanks are punched out in the manner shown, the sixteen holes in the metal from which blanks have been cut are numbered and lettered the same as the die. The metal is fed through in the usual way, which is from right to left, and the holes are, of course, pierced before the blanks

are cut. By referring again to Fig. 8, the lay-out for cutting two, three, four, five, six and seven blanks can be determined. The parts numbered and lettered 1-A and 5-E are the lay-out for two blanks; for three blanks, 1-A, 2-B, and 5-E; for four blanks, 1-A, 2-B, 5-E, and 6-F; for five blanks, 1-A, 2-B, 3-C, 5-E, and 6-F; for six blanks, 1-A, 2-B, 3-C, 5-E, 6-F, and 7-G; for seven blanks, 1-A, 2-B, 3-C, 4-D, 5-E, 6-F, and 7-G. It should be remembered that all holes in dies of this kind are lapped or ground to size after hardening; they should

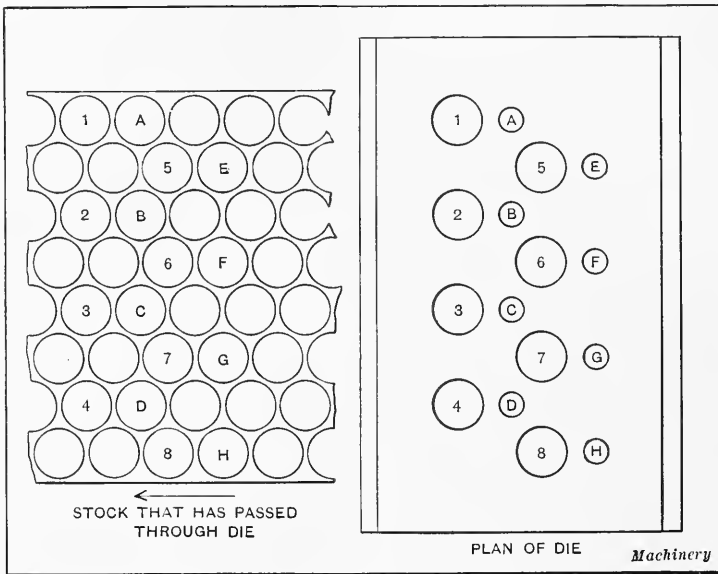

Fig. 8. Die for Piercing and Blanking Eight Washers Simultaneously

be perfectly round and have 1 degree clearance. In some shops the holes are left straight for  $\frac{1}{4}$  inch, and then tapered off 2 degrees.

**Templets for Blanking Dies.** — When making a blanking die it is common practice to begin by making a templet that conforms to the shape of the blank which the die is to produce. This templet is then used as a gage when finishing the hole in the die. Sheet steel is commonly used for templets. The thickness depends somewhat upon the size of the templet, but for comparatively small work, steel about  $\frac{3}{32}$  inch thick will suffice.

The outline of the templet should be laid out very carefully, and finished to conform exactly to the required shape and size of the hole to be cut in the die blank. It is absolutely necessary, if accurate work is to be produced by punches and dies, that the templet be accurate. This is one of the first points which the diemaker should be sure of before beginning to make the punch die. At times it requires a considerable degree of skill to make a templet that will answer for the work in hand.

As an example, the templet shown at *A* in Fig. 9 may be referred to. After blanking and bending the small projection at the top of the piece to be made, it was to be closed around a

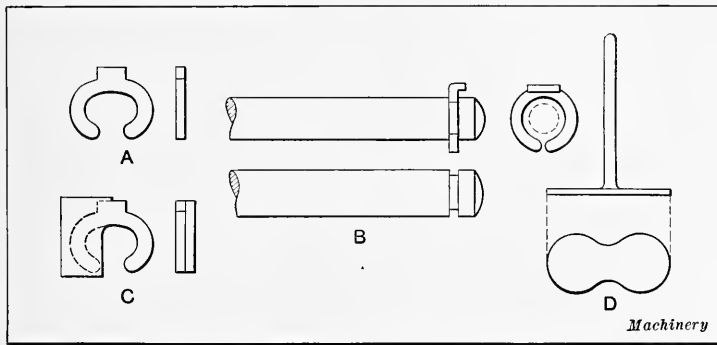

Fig. 9. Examples of Blanking Die Templets

groove in the end of the rod, as shown at *B*. After closing, the outside of the blank was supposed to be circular. The die was made to a templet and it was found less difficult to make the die than the templet. In this instance, it was necessary to make two pieces of the desired shape exactly alike, one of which was closed on the grooved rod and tested. The points that were not right were located on the one that had not been closed up. Then others were laid out from it, due allowance being made for the imperfections of the first. When making the templet, two pieces of stock were placed together, and one half was worked to the laying out lines, as shown at *C*. After the other half had been blocked out somewhere near the line, the pieces were reversed and each half that had been blocked out was filed to conform to the finished half. In this way the ends were made

duplicates. When one templet was forced down or closed on the rod and was found correct, the other answered for the templet to be used in laying out the die, and as a gage when finishing the hole in the die.

In order that templets may be easily handled, it is customary to attach some form of handle to them, which is sometimes done by drilling and tapping a hole in the templet, and cutting a short thread on a piece of wire which is screwed into the tapped hole. Another common method is to attach a piece of wire by means of a drop of solder, as shown at *D*.

**Laying Out Die from Templet.** — The templet or master blank for a blanking die may be used for laying out the die by trans-

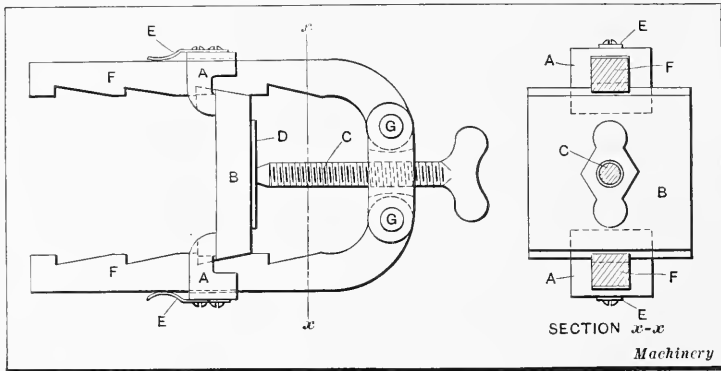

Fig. 10. Diemakers' Crab Clamp

ferring the outline of the templet directly to the die-face. The top surface of the die blank should be brightened with a piece of emery cloth, and the surface prepared for laying out by either applying a coppering solution or by heating the die blank evenly all over until a dark blue color is obtained, and then immersing it in oil. The surface will then be either coppered or blued, depending upon the method employed, and on such surfaces all lines made by a sharp scribe will be bright, and made plainly visible by the contrast with the darker background. The templet, or master blank, can now be used for laying out the die. It is first clamped on the face of the die blank; then, by following the outline of the templet with a

sharp scribe, its shape is transferred to the face of the blank. Before locating the templet, however, the most economical way of cutting the blanks from the stock must be determined; that is, the way to obtain the greatest number of blanks from a given weight of stock, as explained in connection with the laying out of blanking dies.

A type of clamp which is very convenient for clamping the templet to the die-face, as well as for other die work, is shown in Fig. 10. With this clamp there is no time wasted in screwing the clamp screw *C* up and down when pieces of different thicknesses are placed between the arms *F*, because the jaws *A* are made so that they can slide up and down on the arms *F*, which are provided with steps or notches so that the jaws can rest at various places on them as shown. The springs *E* act as frictions, and prevent the jaws from dropping when not resting on the steps. The arms *F* swing on pins *G*, thus making it possible to accommodate various widths of the die blanks.

**Machining Opening in Blanking Die.** — After the die has been laid out accurately the next step is to machine the hole for the blanking punch. The way in which this is done will, of course, depend somewhat upon the shape of the blank which is to be produced. As the hole through the die which we have selected as an example (which is shown in Fig. 11) has circular ends, the lathe can be used to advantage for machining these ends. When dies have circular ends or arcs, the machining of the opening can also be facilitated by drilling, the sizes of the drills being selected with reference to the radii of the circular sections. For instance, if the core of the die illustrated in Fig. 11 were to be removed entirely by drilling, a large drill should be used for the circular ends and a smaller size for drilling the rows of holes about the central core. Of course, boring out the ends in the lathe would be a more accurate method than drilling. When drilling a row of holes for the purpose of removing a core (which is a very common method) if each alternate hole is first drilled, as indicated at *A*, and then the remaining ones, the holes can be spaced closer and drilled with less difficulty, and there will be no bridges between adjacent holes to hold the core in place.

As a blanking die must have clearance, in order that the blanks, when sheared from the stock, may fall through the die, it is common practice, when drilling, to insert a thin strip beneath the blank and on the side farthest from the hole being drilled, so that the hole is inclined from the vertical equal to the clearance angle. The holes can also be drilled at right angles to the face of the die and then be reamed out with a taper reamer, but the former method is more practicable.

After drilling, most of the surplus metal can be removed with a sharp chisel, but if the die is large it can be machined on the

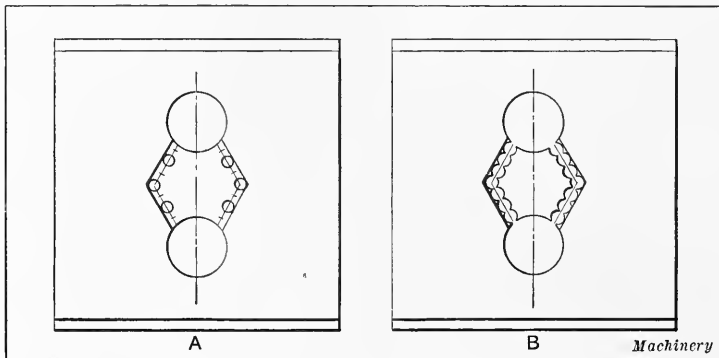

Fig. 11. Example Illustrating Method of Removing Core of Blanking Die

planer or shaper by strapping it to an angle-plate which is inclined to the vertical sufficiently to give the die the proper amount of clearance, or by clamping it between two  $1\frac{1}{2}$  degree parallels. Of course, this work may be done more easily on a regular die-slotting machine or die shaper, if one is available. If chipping is resorted to, the chisel should always be driven away from the top of the die as there is danger, when chipping from the other direction, of the metal breaking away outside of the lines. At times it may be advantageous to drill a single hole large enough to insert a milling cutter, and then work out the core on a vertical milling machine, or a horizontal machine with a vertical attachment. A taper cutter can then be used for giving the die clearance. Regular die milling machines are also commonly used, and the slotting attachments for universal milling machines are also convenient for machining blanking dies.



**Die Shaping and Slotting Machines.**—A machine that is especially adapted for die work is shown in Fig. 12. This is a Pratt & Whitney vertical shaper, and the operation illustrated is that of machining the openings in a die for armature disks. The work-table of this shaper can be given a transverse, longitudinal, or rotary movement. The ram which carries the plan-

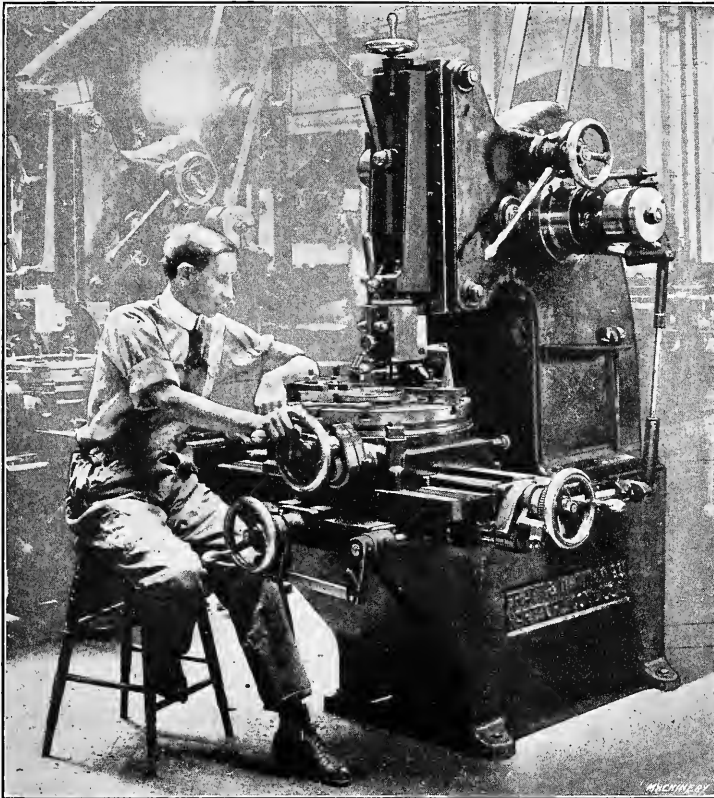

Fig. 12. Machining Holes in Armature Disk Die in a Vertical Shaper

ing or slotting tool moves vertically while the table is fed, either by hand or automatically, in whatever direction is required. The ram is mounted in an independent bearing, the upper part of which is pivoted on a trunnion that enables the bearing and ram to be set in an angular position which is indicated by degree graduations. This feature makes the machine very con-

venient for machining openings in blanking dies, because the excess metal is readily removed and at the same time a uniform clearance angle is given to the cutting edge of the die.

The tool is held in a slotted toolpost carried in a clapper which permits the tool to clear the work on the return stroke,

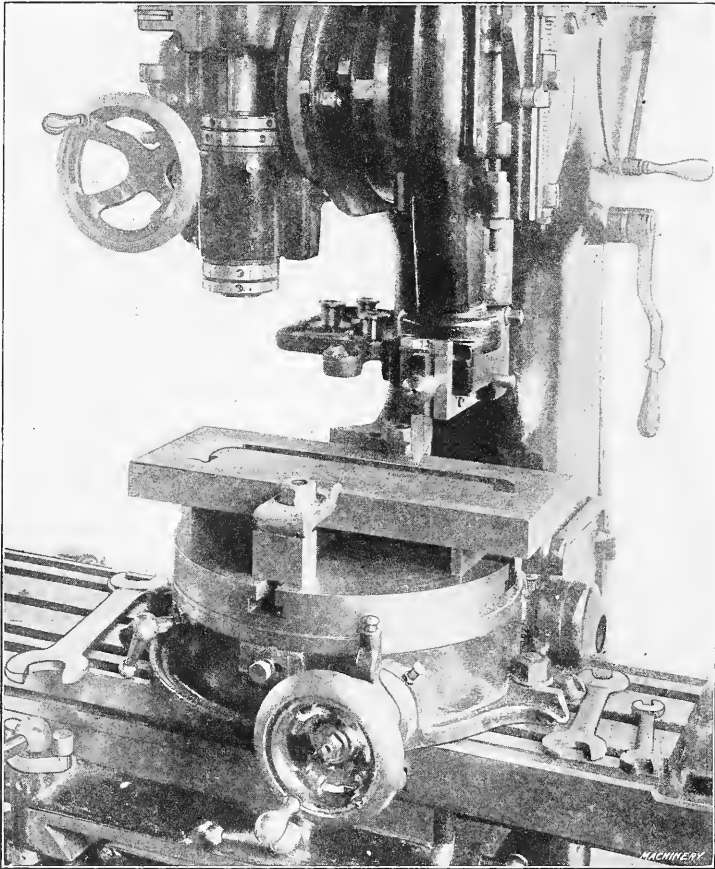

Fig. 13. Universal Shaper Arranged for Slotting a Blanking Die

the same as on a horizontal shaper. When exceptionally long tools are required on internal work, the clapper can be clamped rigidly to the head. The tool-head can be swiveled to four different positions so that the tool can be set for slotting different sides without changing the position of the table and by simply

using the transverse or longitudinal feeding movement, thus insuring accuracy between the surfaces.

The machine shown slotting out a blanking die in Fig. 13 is known as a universal shaper, although it is, in reality, a shaper, slotter, milling and drilling machine combined. This machine (built by the Cochrane-Bly Co.) is especially adapted for die work, and, owing to its universal features, drilling, milling, and shaping or slotting operations can be performed at one setting of the die. For instance, when making a blanking die, the opening can be machined by first drilling a hole to form a starting place for the slotting tool; the latter may then be used to remove the core, after which the edges are slotted out to the required form and clearance angle and close to the finished size, so that little filing is necessary. Power feed is provided for the longitudinal cross-movements of the table. The machine also has either a continuous or intermittent feed. When the milling spindle is being used, the feed is continuous, whereas an intermittent feed, which takes place on the return stroke, should be used when the shaper ram is in action. Tool-holders of various styles for holding slotting or shaping tools can be attached to the head. The ram is equipped with a mechanism which provides a positive relief for the tool on the upward or return stroke. Both the shaper and the milling heads have an independent adjustment about an axis at right angles to the main head, which makes it possible to locate them at any angle. The auxiliary circular table shown in Fig. 13 may be rotated by hand or by means of a power feed. The periphery of the table is graduated in degrees and the dial enables it to be adjusted within  $2\frac{1}{2}$  minutes of a given angle. The handwheel shown in the illustration may be replaced by a dividing attachment having index plates and a sector, similar to the dividing head of a universal milling machine. This attachment is convenient when machining dies that require accurate spacing.

The openings in blanking dies are often machined in slotters especially designed for work of this class. A die slotter which represents a typical design is equipped with a short-stroke ram which can be set at an angle with the work-table for machining

the required amount of clearance. The table is circular and can be rotated for slotting circular openings. This circular table is mounted on compound slides which provide lateral and transverse feeding movements. The machine is of the column-and-knee construction, thus providing vertical adjustment for the work-table.

Blanking dies are also slotted on an ordinary column-and-knee type milling machine, by using a slotting attachment. This attachment is bolted to the face of the column and is driven

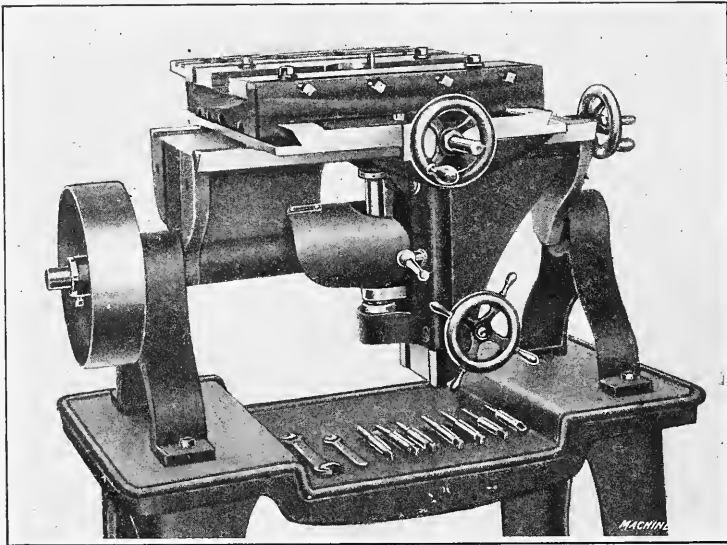

Fig. 14. Thurston Die Milling Machine

from the main spindle of the machine through suitable gearing, which transmits motion to the crank that operates the slotter ram.

**Undercutting Die Milling Machine.** — A machine especially designed for die work is shown in Fig. 14. This machine is so arranged that the cutter is driven from beneath the work-table and extends up into the die opening instead of being held by a spindle from above. One advantage of this construction is that lines on the die-face showing the outline or contour of the die opening are not obstructed by the cutter or spindle. The die

to be milled is held on a table which is carried by cross and longitudinal slides. By manipulating the handles which operate the two slides, the work is fed against the milling cutter in the required direction. The cutter may be either straight or tapered to suit the amount of clearance required for the die opening. When using this machine, it is necessary to drill a hole through the die to form a starting place for the cutter which is then fed around the outline of the die opening, thus cutting out the entire core or center in the form of a solid block. The raising or lowering of the cutter-slide is effected by means of the lower handle seen at the front of the machine, whereas the upper handle and the one at the right end control the cross and longitudinal movements, respectively. There is a pointer on the machine which remains in a fixed position with reference to the cutter, so that when the latter is operating below the surface of the die the pointer indicates its position. The entire frame of the machine is mounted on trunnions, so that the work can be inclined to any desired position, in order to give the operator the best possible light on the surface being milled.

**Finishing a Blanking Die by Filing.** — After the opening in a blanking die has been machined to approximately the required shape and size, the exact shape and size is ordinarily obtained by filing. This may be done by hand or in a filing machine. When the die is to be filed by hand it is fastened in a vise with its top or face toward the back of the vise. The hole is then filed until it fits the master blank or templet. The templet should be frequently tried in the hole, the bearing points being marked with a pencil, and then removed with the file; this operation is repeated until the hole fits the templet perfectly and is large enough to allow it to just pass through. When testing the hole, the surface of the templet should be kept parallel with the top of the die. As the work is nearing completion, it may be necessary to remove it from the vise each time the templet is inserted, to enable one to see the minute openings. A piece of white paper held on the opposite side of the blank will, however, suffice for the earlier stages of the work. When filing, it is sometimes advisable to protect ends

which may have been finished previously by the method illustrated in Fig. 15. Piece *A* prevents the edges of hole *P* in the die from coming into contact with the edge of the file when the die is filed out. Piece *B* simply serves the purpose of permitting the die to be held parallel in the vise.

When finishing the hole in the die, the clearance should be filed as straight as possible, so that the blanks, when cut, can easily fall through the opening. To file a narrow surface straight is difficult and requires considerable practice, and while one becomes proficient in work of this kind only through practice,

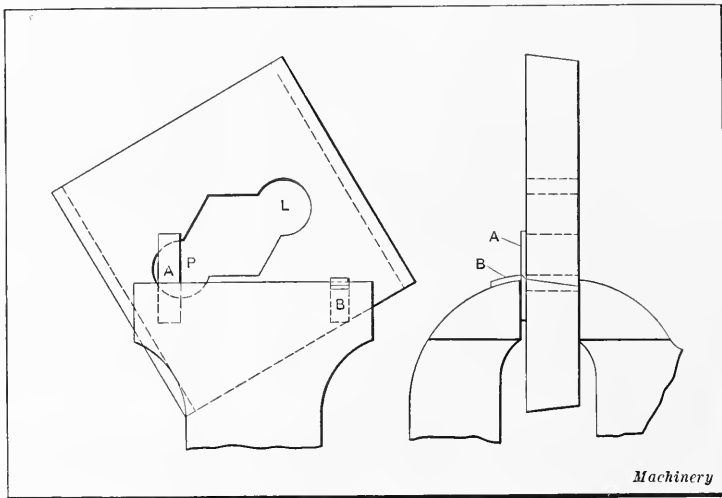

Fig. 15. Blanking Die in Vise ready for Filing

still a hint as to the proper method of procedure may be useful. When the file begins its stroke, the downward pressure exerted by the left-hand holding the outer end should be maximum, while a minimum pressure is given by the right-hand; as the file advances, the pressure from the left-hand decreases, while that from the other increases. After considerable practice, one is enabled, unconsciously, to regulate the pressure on each end of the file so that any "rocking" motion of the file is prevented. If the surface being filed becomes rounded this can usually be remedied by using a sharp scraper which will cut the metal quite rapidly. In filing out the die, it is convenient to have a set of

small "squares" which vary from ninety degrees, an amount equal to the angle required on the die for clearance. These may be made from  $\frac{1}{16}$ -inch sheet steel with the base  $\frac{1}{2}$  inch wide by 2 inches long, and the beam  $\frac{1}{8}$  inch wide by  $1\frac{1}{2}$  inch long, or they can be made to suit the requirements. It is generally found advisable to have these ranging from  $\frac{1}{2}$  degree to 2 degrees, vary-

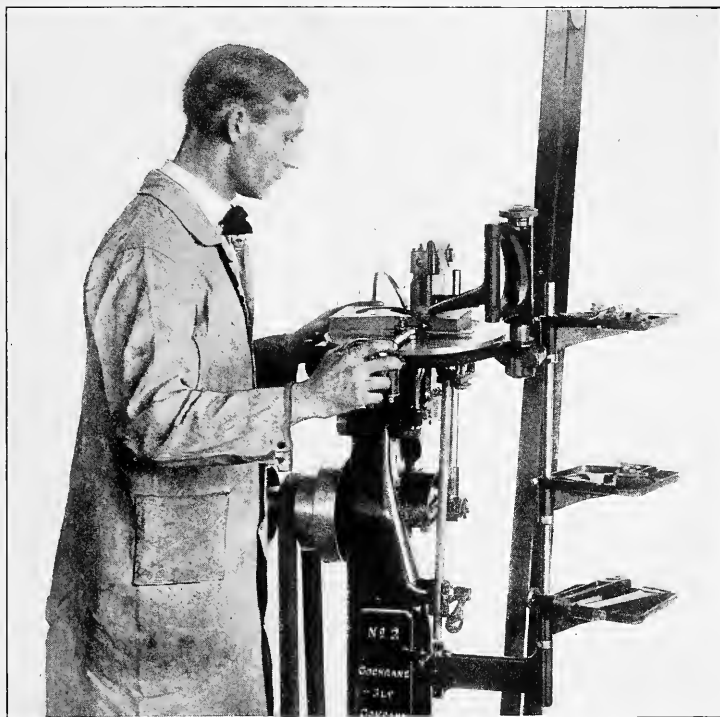

Fig. 16. Cochrane-Bly Filing Machine at Work on a Blanking Die

ing by  $\frac{1}{2}$  degree. The number of degrees that these vary from 90 should be marked on the different squares to designate them.

**Die Filing Machines.** — Vertical filing machines are used by many diemakers for filing the openings in blanking dies. The use of a Cochrane-Bly filing machine is indicated in Fig. 16. The table of this machine is adjustable about two axes at right angles to each other so that it can be tilted for filing clearance in dies, as well as for other angular work. A screw feed, operated

by hand, is provided for feeding the work against the reciprocating file. The stroke of the file is adjustable from zero to 4 inches and it is arranged to clear the work on the return stroke. The cutting stroke can be either on the upward or downward movement, this change being effected by simply shifting the crankpin to the opposite side of the crank-arm. An adjustable finger is provided for holding the work firmly to the table but

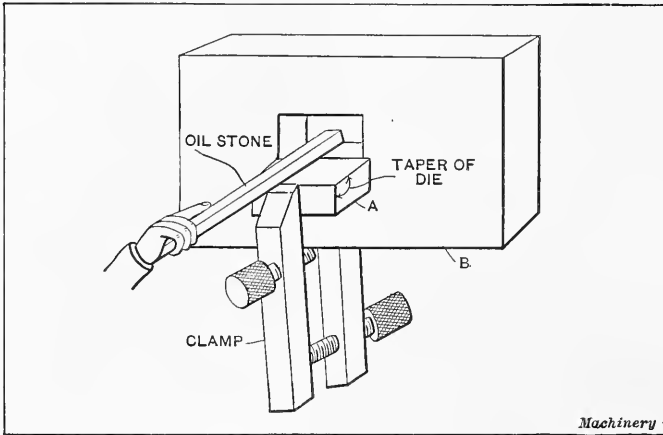

Fig. 17. Diagram Illustrating Method of Stoning out a Blanking Die

allows it to be moved freely in any direction on the table. An air pump blows away the chips and filings and keeps the work and file clear, thus insuring a smooth cut. The file may be clamped either above or below the table, or at both ends. The file is supported at the free end by means of a special arm which carries an adjustable finger that bears against the file at the back. A pair of arms for holding hacksaw blades is also provided, which may be attached to the slide in place of the file arms. Saws are sometimes employed for cutting out the core of the die. One advantage of the die filing machine, as compared with hand filing, is that straight or flat surfaces can be filed without difficulty because the file is mechanically guided and moves in a straight line, whereas, when filing by hand, it is difficult to do the work accurately.

**Method of Stoning Out a Die.** — Stoning or lapping out a die, to correct slight distortions due to changes in hardening, is



often a tedious job and can be much more easily accomplished when using suitably placed guides or guards for the stone. As an example, consider a die like the one shown in Fig. 17, having a square hole to be stoned out. First the outside of the die is ground as nearly parallel with two of the sides of the square hole in the die as possible. Then a block *A*, made of soft steel, having two sides beveled at the same angle as the die, is set parallel with surface *B* and at the correct height. During the lapping operation this block *A* will furnish a good guide for the stone or lap.

**Clearance Between Punches and Dies.** — The amount of clearance between a punch and die for blanking and perforating,

**Clearances Between Punches and Dies for Different Materials**

Thickness of Stock, Inches	Clearance, Inches			Thickness of Stock, Inches	Clearance, Inches		
	Brass, Soft Steel	Medium Rolled Steel	Hard Rolled Steel		Brass, Soft Steel	Medium Rolled Steel	Hard Rolled Steel
0.010	0.0005	0.0006	0.0007	0.120	0.0065	0.0072	0.0084
0.020	0.0010	0.0012	0.0014	0.140	0.0075	0.0084	0.0098
0.030	0.0015	0.0018	0.0021	0.160	0.0085	0.0096	0.0112
0.040	0.0020	0.0024	0.0028	0.180	0.0095	0.0108	0.0126
0.050	0.0025	0.0030	0.0035	0.200	0.0105	0.0120	0.0140
0.060	0.0030	0.0036	0.0042	0.220	0.0115	0.0132	0.0164
0.070	0.0035	0.0042	0.0049	0.240	0.0125	0.0144	0.0178
0.080	0.0045	0.0048	0.0056	0.260	0.0135	0.0156	0.0192
0.090	0.0050	0.0054	0.0063	0.280	0.0145	0.0168	0.0206
0.100	0.0055	0.0060	0.0070	0.300	0.0155	0.0178	0.0220

or the difference between the size of the punch and die opening, is governed largely by the thickness of the stock to be operated upon. For thin material such as tin, for example, the punch should be a close sliding fit, as, otherwise, the punching will have ragged edges, but for heavier stock there should be some clearance, the amount depending upon the thickness of the material. The clearance between the punch and die when working heavy material lessens the danger of breaking the punch and reduces the pressure required for the punching operation. To obtain the clearance between the punch and die, divide the

thickness of the stock by a number or constant selected according to the following rules which apply to different materials: For soft steel and brass, divide the thickness of the stock by the constant 20; for medium rolled steel, divide by 16; for hard rolled steel, divide by 14.

*Example.* — What would be the clearance between a punch and die to be used for perforating or blanking soft steel 0.050 inch thick?

$$\frac{\text{Thickness of stock}}{20} = \frac{0.050}{20} = 0.0025 \text{ inch.}$$

Whether this clearance is deducted from the diameter of the punch or added to the diameter of the die depends upon the nature of the work. If a blank of given size is required, the die is made to that size and the punch is made smaller. Inversely, when holes of a given size are required, the punch is made to correspond with the diameter wanted and the die is made larger. Therefore, for blanking to a given size, the clearance is deducted from the diameter of the punch, and for perforating, the clearance is added to the diameter of the die. To illustrate, suppose we want to blank hard rolled steel having a thickness of 0.0625 inch (No. 16 gage) to a diameter of 1 inch. What would be the sizes for the punch and die? The clearance equals  $\frac{0.0625}{14} = 0.0044$  inch. As this is a blanking operation, the die is made 1 inch, and the punch diameter equals  $1 - 0.0044 = 0.9956$  inch.

A loose fitting punch will cut absolutely free from burrs up to a certain point, but, if it is a little too loose or a little too tight, ragged edges will be left on the punchings as the result. A general rule which is sometimes used to determine the clearance is to allow a clearance between the punch and die equal to 6 per cent of the thickness of the stock to be cut. For example, suppose a punch and die is required for cutting plain steel washers 0.040 inch thick. Then six per cent of the thickness of the stock equals  $0.040 \times 0.06 = 0.0024$  inch, which would be the difference between the size of the punch and the die.

**Angular Clearance for Dies.** — The amount of angular clearance ordinarily given a blanking die varies from one to two degrees, although dies that are to be used for producing a comparatively small number of blanks are sometimes given a clearance angle of four or five degrees to facilitate making the die quickly. When a large number of blanks are required, a clearance of about one degree is used. There are two methods of giving clearance to dies: In one case the clearance extends to the top face of the die as indicated at *A* in Fig. 18; in the other, there is a space about  $\frac{1}{8}$  inch below the cutting edge which is left practically straight, there being a very small amount of clearance. A die of this type is illustrated at *B*. For very soft

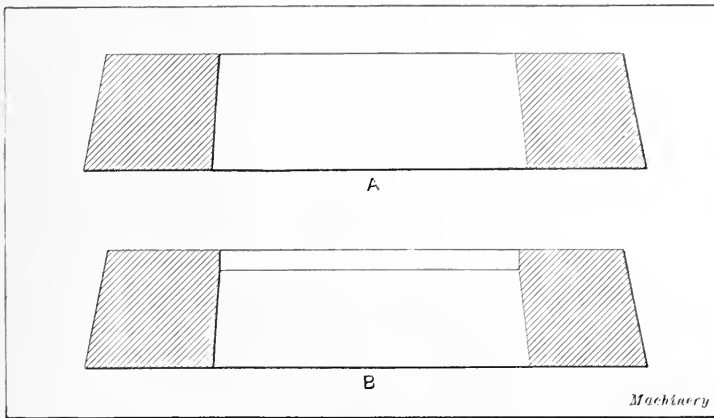

Fig. 18. Sectional Views of Blanking Die Illustrating Two Methods of giving Clearance to the Cutting Edge

metal, such as soft, thin brass, the first method is employed, but for harder material, such as hard brass, steel, etc., it is better to have a very shallow clearance for a short distance below the cutting edge. When a die is made in this way, thousands of blanks can be cut with little variation in their size, as grinding the die-face will not enlarge the hole to any appreciable extent.

**Fitting the Punch to the Die.** — It is customary to make the die and harden it, and then make the punch and fit it to the die. After squaring the end of the punch that is to enter the die, the surface is colored with blue vitriol solution, or by heating it

until a distinct brown or blue color is visible, after which the desired shape is marked on the face by scribing. It is often considered advisable to lay out the shape by means of the templet or master blank, but if the templet is not of the same shape on its two edges, or if the shape is irregular and not symmetrical, it will be necessary to place the opposite side against the punch from that placed against the die; therefore, it is the practice, in many cases, to mark the punch from the die instead of using the templet. If the face of the die is given shear (the purpose of which will be explained later), the punch should be marked before the die-face is changed. When laying out several punches from a die which has a number of openings, it is necessary to lay out the punch from the die.

Before transferring the outline of an intricately shaped die to the punch, it is good practice to coat the face of the blanking punch with solder; then machine the solder so that it is level. Coating the punch with solder enables one to obtain a much better outline than would be possible when scribing on the hard steel, and the very narrow and intricate parts can be laid out more easily. If  $\frac{1}{16}$  inch of solder is evenly placed on the punch, it allows the die to cut a perfect impression in the solder, which is a great help in milling the punch, as the milling cutter can be brought down until it just scrapes the solder, and the cut taken. At the completion of the milling operation the solder is removed.

The surplus stock on the punch is removed by filing, chipping, milling or planing, as the case may be, until it is but a trifle larger than the opening in the die. The end is then chamfered or beveled somewhat so that it enters the opening, and the punch is forced into the die a little way. It is then removed, the stock cut away, and the punch forced in again somewhat farther. This process is continued until the punch enters the die the required distance. It is then filed or scraped until the desired fit is obtained. When shearing the punch through the die, be sure that it stands perfectly square with the top face of the die. Care should also be taken to see that the die does not remove too much stock. If the die removes a nice curling chip from the punch it is not removing too much stock, but if the chip cracks

and breaks as it is severed, it is obvious that it is removing too much stock, and before going any further the punch should be removed and reduced in size, at the point or points where the die was removing too much stock. It is advisable always to use oil on the punch when shearing it through the die.

There are instances in which it is advisable to make punches somewhat differently from the method described. When the nature of the stock to be punched is such as to cause it to cling to the punch, making the operation of stripping difficult, to the extent that any stripper plate put on the die would be bent, or the end of the punch pulled off during the operation, the punch may be made straight for a distance that allows of grinding several times; then the portion immediately above this may be given a taper. This tapered portion of the punch is intended to enter the stock, *but not the die*. Its action is to increase the size of the opening somewhat, thus making the operation of stripping possible without endangering either the stripper or the punch.

Punches for piercing and blanking copper should be polished quite smooth, as copper clings tightly and is difficult to strip from the punch. If the punch is left rough, the force necessary to strip the blank from the punch is very likely to bend it out of shape or to break the punch.

**Methods of Holding Punches.** — Punches are attached to their holders in quite a variety of ways. The method may depend upon the size and shape of the punch and whether it is to be used singly or in combination with other punches. The service for which the punch is intended is another point that should be considered; that is, whether the material to be punched is light or heavy and also whether the die is for producing a comparatively few parts or is intended for continuous service. When punching heavy material, the punch must be firmly secured against vertical thrust in either an upward or downward direction, because when the punch ascends and is stripped from the stock, it is subjected to a heavy downward pull. If the die is a type intended for a small amount of work, a cheap and quick method of making both the punch and the die would

ordinarily be employed. The personal ideas of the designer or toolmaker also affect the construction of punches and dies, and even those who have had wide enough experience to qualify as experts often disagree on important and fundamental points. Therefore, owing to the different factors which govern punch and die design, the practice is variable and far from being standardized.

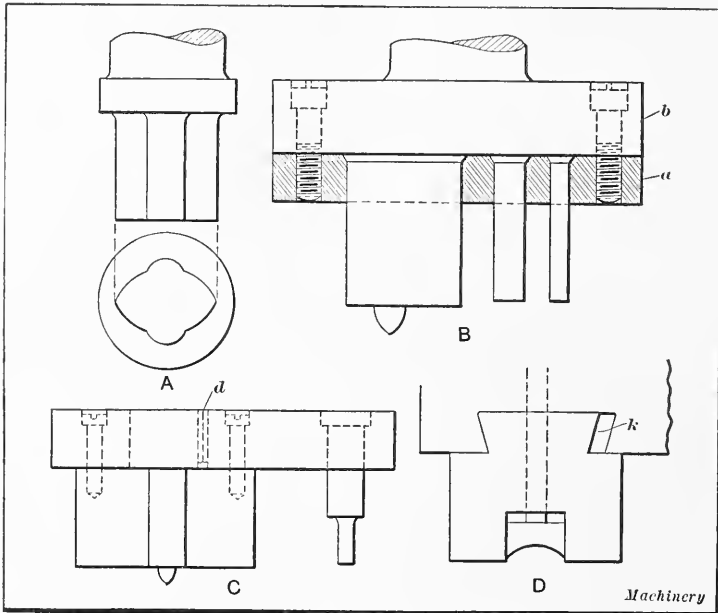

Fig. 19. Different Types of Punches

A number of different methods of attaching punches, which are commonly employed in diemaking practice, are referred to in the following. When only a single punch is required, it is ordinarily made in one solid piece, as illustrated at *A*, Fig. 19, the punch being integral with the round shank which enters and is clamped in the ram or slide of the press. Usually it is necessary to fasten several punches to a holder and then the construction is different. The method illustrated at *B* is common, especially when the shapes of the punches are not intricate or very irregular. As the diagram shows, each punch passes through a punch plate *a* and bears against the punch-holder *b*.

The upper end is riveted over to prevent the punch from pulling out when being stripped from the stock, and the punch plate is held to the holder by machine screws, as shown. Evidently, a round piercing punch can easily be attached in this way, but if the shape is very irregular, the work of machining the opening in the punch plate is much more difficult. Furthermore, if thick material is to be punched, there is danger of pulling out the punches when stripping the stock, especially if they are not well riveted at the top; therefore, some diemakers only hold punches in this way when the openings in the punch plate are readily machined and the punch is intended for medium or light service. Another disadvantage connected with the construction illustrated at *B* is that if the punch is not tightly fitted to punch plate *a*, it tends to loosen. For instance, if the press operator should make a miscut or a "half-cut," the punch which is not sufficiently rigid springs to one side and either shears off or loosens the riveted end, thus causing trouble. This method, however, has been used extensively and with satisfactory results.

Another way of holding punches is illustrated at *C*. The large blanking punch at the left is provided with a round shank which is driven tightly into the punch plate. The punch is prevented from turning by a dowel-pin driven in at *d*, and, in addition, machine screws are used to prevent the punch from pulling out of the plate when stripping the stock. This method of holding a blanking punch, especially if the shape is quite irregular, is preferred by some diemakers, because it is only necessary to machine a round hole through the punch plate instead of an irregular opening such as is required when the punch passes through the punch plate. In some cases, two dowel-pins, placed as far apart as possible, would be used instead of one dowel at the side of the shank. If the punch were intended for quite heavy material, it might be advisable to rivet over the end of the shank, although riveting makes it more difficult to remove the punch, if this should be necessary.

The diagram *D*, Fig. 19, illustrates how punches are sometimes held in a dovetailed groove in the holder. The slightly

tapering key *k*, which is driven in at one side, holds the punch securely in place. The slides of some presses have a dovetailed slot across the lower end so that punches may be attached to them directly by a dovetailed fitting. This method is especially desirable for large punches or those subjected to heavy duty.

Still another arrangement, which is a modification of the one illustrated at *C*, Fig. 19, is shown at *A*, Fig. 20. The blanking punch is provided with a shank and is riveted over at the top, but, instead of using dowel-pins to secure it in position, a slot or groove is planed part way through the punch-holder as the illustration shows. The sides of the blanking punch are made

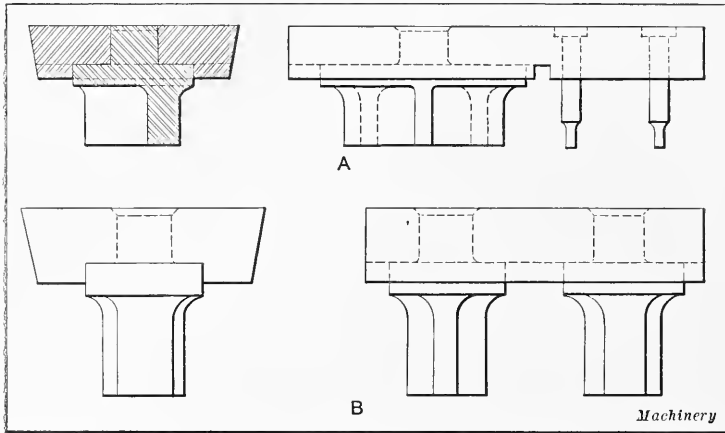

Fig. 20. Illustrating Method of Attaching Blanking Punch to Punch Plate

to fit tightly into this groove or channel, thus giving it a rigid support. This same method, as applied to the holding of two blanking punches in the punch-holder, is illustrated at *B*. These two punches are used in connection with a double-blanking die for cutting two blanks at one stroke of the press. In this case, the slot is milled along the entire length of the punch-holder and the punches are driven in and securely held in position in the same manner as indicated at *A*. The advantage of attaching an irregular blanking punch to a punch-holder in this way, as compared with the method illustrated at *C*, Fig. 19, is that it does away with all screws or dowel-pins and gives a rigid construction.



The method of attaching a punch illustrated at *A*, Fig. 21, is similar to the method shown at *C*, Fig. 19, except that the blanking punch is held to the punch-holder by a shank against which a set-screw is tightened. The shank is spotted to receive the end of the set-screw, and this spot is slightly offset so that the punch will be drawn upward against the collar when the set-screw is tightened. As will be noted, the group of small piercing punches to the right is attached by a separate punch plate which is screwed to the holder, as shown by the lower plan view.

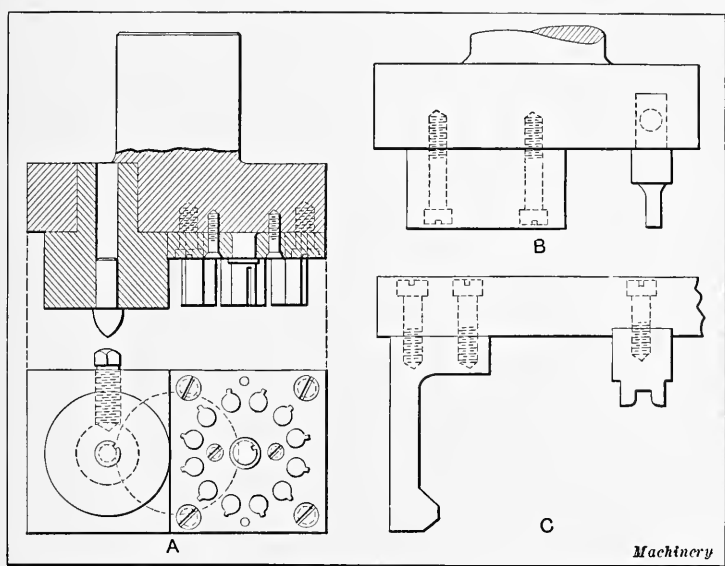

Fig. 21. Different Types of Punches

Some punches are simply attached to the holder by machine screws, dowel-pins being used to keep them in position. An example is shown at *B*, Fig. 21. This is a cheap construction and is usually employed when the die is only intended for temporary use. Obviously, the punch should not be held in this way if it is to be used on heavy stock, owing to the excessive downward thrust or pull when stripping the stock. For many operations, such as bending, curling, or cutting light blanks, the downward pull is light and screws may be used. Sketch *C*, Fig. 21, shows part of a bending punch which is held together

by screws. Large punches for blanking, bending, drawing, or curling are often bolted directly to the press slide.

**Types of Piercing Punches.** — Piercing punches are made in several different forms and attached to the punch-holder in different ways, as indicated by the diagrams in Fig. 22. The form of punch used, in any case, depends to some extent upon the purpose for which the die is intended. The set-screw method of holding the punch, illustrated at *A*, is not to be

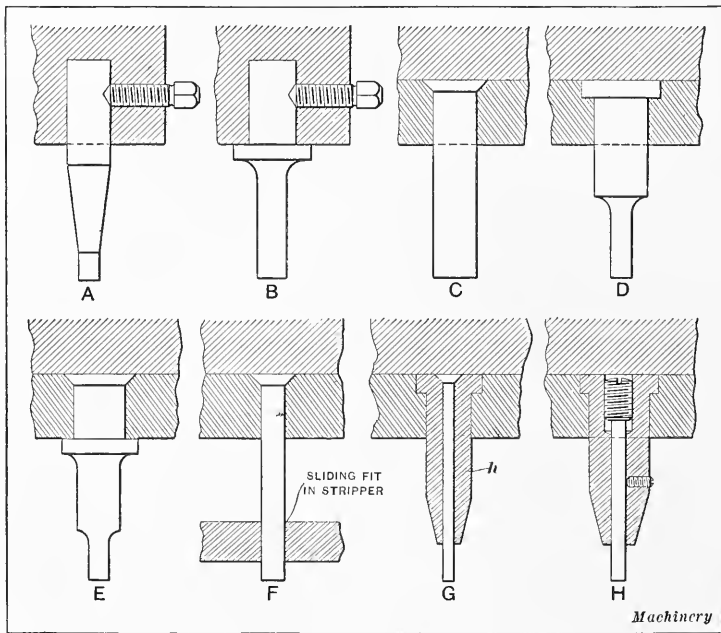

Fig. 22. Various Methods of Holding Piercing Punches

recommended but is sometimes used in cheaper grades of dies. Punches of this kind are occasionally made with taper shanks in order to secure a better fit on the punch-holder and lessen the tendency of the punch to become loose. The punch *B* is sometimes used where it is desirable to have the punch seat on the face of the punch-holder instead of at the bottom of the hole into which it is driven. This punch, of course, is more expensive to make than one not having a collar but the construction is much better.

The methods illustrated at *C*, *D*, *E*, and *F* are employed when a large number of punches are to be located close together or when it is necessary to detach them from the head without disturbing the alignment. With either of these methods the punch passes through a punch plate which, in turn, is secured to the punch-holder by machine screws. Referring to sketch *C*, it will be seen that the upper end of the punch is riveted over and abuts against the punch-holder, whereas punch *D* has a head which rests in a counterbored seat in the plate. The form shown at *D* is considered by many diemakers to be an ideal method of making and attaching a small punch of this kind, because it has a firm support against the upward thrust when punching and is also securely held while the stock is being stripped. This method of holding is especially adapted for punching heavy material. Punch *E* has a shoulder the same as punch *B* but the upper end is secured by riveting, as the illustration shows. Obviously, this form cannot be subjected to as heavy a strain or downward pull as would be possible with punch *D*; moreover, it is objectionable because the riveted end must be cut away if for any reason it is necessary to remove the punch. Sketch *F* illustrates a method of guiding and steadying a slender punch which is sometimes employed. The punch is made of straight drill rod and the upper end is riveted over, while the lower end is made a close working fit in the stripper plate attached to the die. Instead of making the punch straight throughout its length, it is good practice to use drill rod of standard size and then turn down the lower end for a length of about  $\frac{1}{4}$  inch and to the diameter of the hole to be pierced. This allows the body part of the punch to be well entered into the stripper plate, in which it should be a close fit, before the piercing operation begins, so that the punch is rigidly supported when at work. The body of the punch should be a driving fit into the punch plate and be riveted over at the upper end and filed flush. When made in this way, the punch will be rigid, even though it is used for piercing small holes, and if it is well supported in the stripper plate, a much smaller punch can be employed than would be possible otherwise. When piercing

heavy stock, it is well to insert a hardened steel disk in the punch-holder just above each piercing punch. This disk prevents the end of the punch from forming a depression which would allow the punch to slide up and down at each stroke.

The piercing punches shown at *G* and *H* are called "quill" punches and are used where a large amount of stock is to be pierced or when the stock is thick in proportion to the diameter

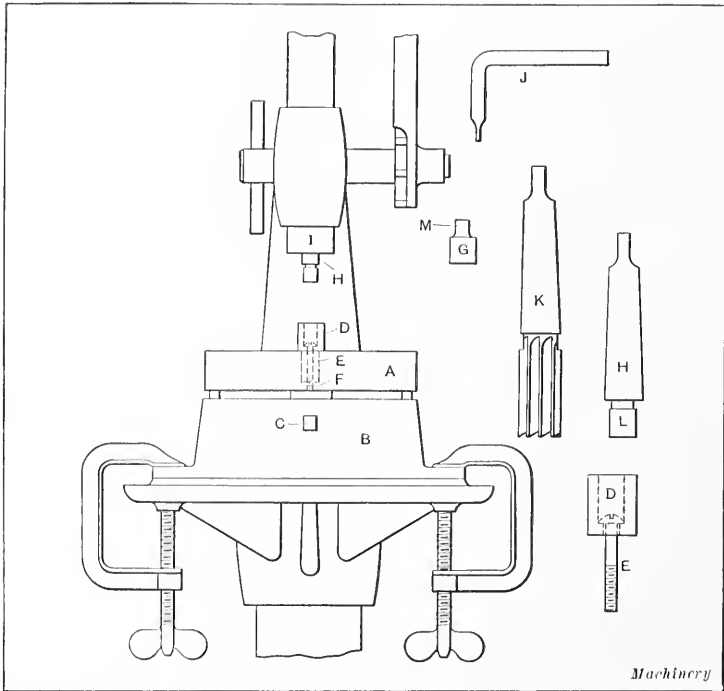

Fig. 23. Simple Method of Locating Piercing Punches in Punch-holder

of the punch. The piercing punch is held in position by the quill or punch-holder *h*, which is driven tightly into the punch plate. The piercing punch is lightly driven into the holder and is made of drill rod, so that it can very readily be replaced in case it is broken. The upper end of punch *G* is riveted over, as the illustration shows. The holder shown at *H* is equipped with a backing screw for the punch so that the latter can be adjusted vertically. The punch is retained by a set-screw.

**Locating Punches in Punch-holder.** — A simple method of locating round, piercing punches in the punch-holder, which has proved very satisfactory, is illustrated in Fig. 23. The holes for the punches can be located, drilled and reamed very quickly, and if reasonable care is taken in setting, the work will be sufficiently accurate for ordinary conditions. This method is used when punches are secured in the punch-holder by set-screws.

Referring to the illustration, *A* is the punch-holder and *B* is a holder made of cast iron, carefully machined top and bottom, and bored to fit the shank of the punch-holder, which is fastened in it by the set-screw *C*, the punch-holder resting on parallels. *D* is a locating button hardened and ground, having a  $\frac{1}{2}$ -inch hole in the upper part and a  $\frac{1}{4}$ -inch hole in the lower part. The  $\frac{1}{2}$ -inch hole should be ground straight and true and with its axis at right angles to the bottom of the button. *H* is a pilot made of tool steel hardened and ground, with a Morse taper shank to fit the spindle of the drill press and has a portion *L* which is made a good sliding fit in button *D*. (See enlarged detail.) *G* is a plug made to fit snugly in the button *D* and has a portion *M*, which is the same size as the body of the punch; it is also made to fit snugly in the templet. These plugs are made in a large variety of standard sizes and form a permanent part of the outfit. The reamer or end-mill *K* is made with a Morse taper shank and is ground so that it will ream a hole which shall be a drive fit for the shank of the punch.

To lay out the holes in the punch-holder for the punches, proceed in the following manner: Lay out the various holes from the templet which was used in laying out the die, and drill holes  $\frac{1}{32}$  inch smaller in diameter than the shank of the punch, to the depth that the punch is to be set in the punch-holder. Then the small hole shown at *F* is drilled and tapped for a button-head machine screw. The first punch-holder is now reamed with the reamer *K* and the punch is driven in place. The button *D* is then held in place with a screw *E* over the next hole in the punch-holder, the plug *G* placed in the button *D*, and with the templet in place on the first punch, the button *D* is located for the second hole and securely held in place by

the screw *E*. The pilot *H* is now placed in the spindle *I* of the drill press and the punch-holder located on the table, so that pilot *H* enters the button *D*. The holder is then held in place by the C-clamps shown, the button *D* removed by means of the bent screw-driver *J*, which is made from  $\frac{1}{4}$ -inch round steel, the pilot *H* removed, and the reamer *K* placed in the spindle of the drill press, when the hole can be reamed to size; the same procedure is followed for all the punches. In using this method it is, of course, necessary to see that the spindle of the drill press is carefully adjusted and that the table lines up properly with it. This same method could also be used on the milling machine.

**Locating Punches in Follow Dies.** — In making follow or tandem dies, considerable trouble is often experienced in getting the small punches to line up properly with the holes in the die. This is especially true when the punch-holders are made of cast iron, as the sand-holes and soft places cause the drill to run out of square, which frequently makes the method of spotting holes through the die impossible. Another method of doing this work consists of placing a jig button on the punch-holder in exactly the same position as the hole in the die with which it is to mate. The punch-holder is then set in a lathe and the button is made to run dead true. The button is next taken off and the hole is drilled or bored to the required size for the shank of the punch. This method requires very careful measurements to be made which, of course, involves a considerable amount of time.

The method to be outlined in the following description does not require any measurements to be made. The first step is to make the guide *A*, Fig. 24. Satisfactory results can be obtained with guides made of cast iron, although it would be better to make them of steel, hardened and ground. The important point is to get the guide hole square with the bottom of the flange; the height of the guide should be  $\frac{1}{8}$  inch less than the height from the surface of the punch-holder to the end of the punch, and the wall around the hole should preferably be  $\frac{1}{8}$  inch thick. The flange is made about  $1\frac{1}{2}$  inch in diameter by  $\frac{1}{4}$  inch thick and is cut away on one side to enable a hole to be made close to a large punch.

The hole in the guide is the same size as the shank of the punch which is to be carried by the punch-holder. The next part to be made is shown at *B*; it consists of a small piece of cold-rolled steel about  $\frac{3}{4}$  inch long. The large diameter *D* is turned so that it will push into the guide without shake, and the small diameter *D*<sub>1</sub> so it can be entered into the hole in the

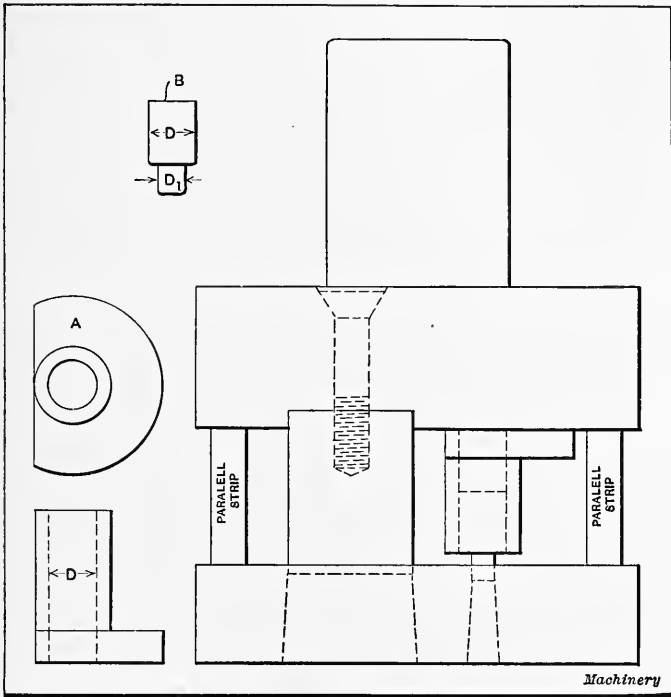

Fig. 24. Method of Locating Punches in Follow or Tandem Dies

die with a light tap. The small end is made about  $\frac{1}{4}$  inch long and the large end  $\frac{1}{2}$  inch in length.

In setting up a job, the small end of the piece *B* is fitted into the die and the large end into the hole in the guide, as shown in the illustration. The large blanking punch is next fastened in the holder and then lowered into the die. Two parallel strips are then placed between the die and punch-holder, which are of sufficient height to keep the holder from striking the guide. The guide is then drawn up against the punch-holder to which

the flange is secured with two parallel clamps. The die is now removed and the pilot taken from the guide; the holder can then be turned up and spotted through the guide with a drill of the proper size to fit the hole. The hole is drilled to the required depth and of a diameter  $\frac{1}{64}$  inch smaller than the required size, the final finish being obtained with a rose reamer. If the reamer is a proper fit in the hole in the guide, the hole in the holder will be square with the surface and line up exactly with the hole in the die. This operation must be repeated for each hole that is required, and after the method has been used in a shop for some time, the necessary guides and plugs for any size of punch will have accumulated, thus saving a considerable amount of time and labor in making punch-holders.

**Shear of Punches and Dies.** — When the cutting face of a die is inclined each way from the center, as at *A*, Fig. 25, or is made hollow, as at *B*, it is said to have *shear*. The cutting faces of dies are given shear for the same reason that the teeth of some milling cutters are made helical or spiral, in that the shear makes it possible to cut the blank from the sheet with less expenditure of power and therefore reduces the strain on the punch and die. Whether a die should be given shear or not depends upon the thickness of the stock to be cut and, in some cases, upon the power of the press available. When comparatively thick material is to be blanked out, shear on the die face reduces the power required, as previously mentioned. A die is also given shear, at times, when the stock is not very thick but for the reason that it is necessary to use a small press.

While it is customary to give shear to the face of the die, there are instances when it is advisable to leave the face of the die flat and give shear to the punch instead. In general, the shear is given to the punch when the stock around the hole is the desired product and the material removed by the punch is the scrap. The face of the die is sheared when the blank or that part which is cut out by the punch is the product. The amount of shear which a die should have to give the best results depends not only upon the thickness of the stock but also



upon the length of the blank to be cut and the power of the press.

Ordinarily the amount of shear  $x$  should equal about twice the thickness of thin light stock, but for heavy material the shear should equal the stock thickness. The exact method of obtaining the shearing effect depends somewhat upon the shape of the die. An oblong or rectangular-shaped die may be given shear as illustrated at either *A* or *B*. The method shown at *B* is generally considered preferable. The die-face is ground so

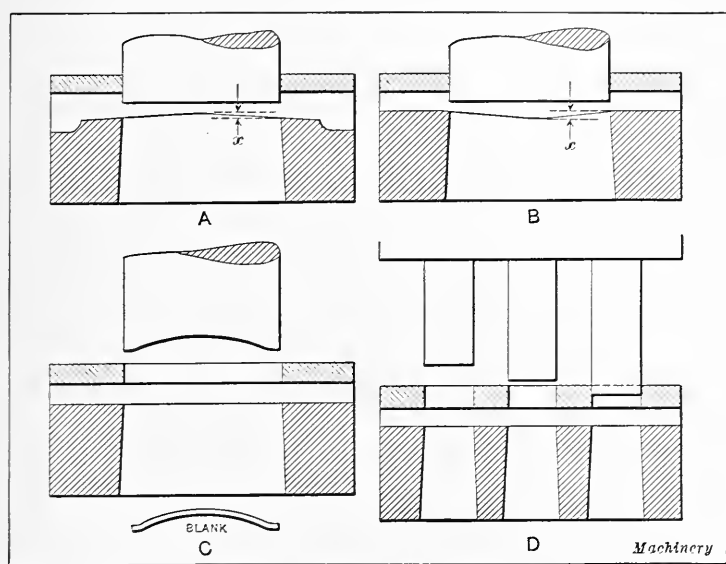

Fig. 25. Diagram Showing how Shear is Given to Cutting Edges

that the cutting edges slope towards the center, which should be rounded and not sharp, because a sharp corner tends to crack the metal at this point. A space about  $\frac{1}{4}$  or  $\frac{1}{2}$  inch wide, depending upon the size of the die, is left flat at the ends. When a die is sheared as at *B*, the punch will begin cutting at both ends instead of at the center, and if the hole in the die is long in proportion to the width, this tends to give better support to the punch because both ends enter the die at the beginning of the cut; moreover, the stock is held more securely during the blanking operation. Some dies are given shear by simply

grinding them concave on the face of the grinding wheel. This concave or circular form is inferior to that shown at *B*, because there is less shearing effect toward the center of the die. The cutting edge of a round blanking die is generally given shear by grinding a series of three or four waves on the top surface, thus leaving a corresponding number of raised portions where the cutting action begins as the punch descends.

As previously intimated, when the face of the punch is left flat and shear is given to the die, the blanks cut out by the punch will be approximately flat and the remaining stock or scrap will be bent and distorted somewhat, whereas, if the shear is given to the punch and the die is left flat, the order will be reversed; that is, the part cut by the punch will be bent and the rest of the stock will come out flat. This effect which the shear has upon the shape of the stock is utilized in some instances in order to cut out a blank and bend it in one operation. The principle is illustrated by the diagram at *C*, Fig. 25. The end of the punch is made to conform to the required shape of the blank; when the punch descends and cuts out the blank the latter is pressed in against the concave end and is bent to shape, thus eliminating a second operation. This method is only practicable for producing blanks of simple form.

The sketch *D* illustrates a method of making a multiple or gang punch which is sometimes resorted to in order to secure the effect of shear. When several holes are to be punched at each stroke of the press, the work can be distributed by varying the length of each successive punch an amount equal to the thickness of the stock or slightly greater; then, as the punch descends, the holes will be punched progressively instead of simultaneously, and, as the longest punch will have passed through the stock before the next one comes into action, the full power of the press is available for each punching operation.

**Hardening Dies.** — When handling work of so diversified a character as the hardening of dies, it is impossible to adopt any set method which is not to be deviated from, as there is no one class of work that calls for a greater exercise of skill and common sense than the proper hardening of dies.

The secret of success in hardening dies by the ordinary method consists in getting as nearly as possible a *uniform* heat. To accomplish this the die cannot be heated very rapidly, as the edges and lighter portions would heat more rapidly than the balance of the piece. Unequal contraction, when quenching in the bath, follows uneven heating, and unequal contraction causes the die to crack. High heats cause cracks in steel. Then, again, high heats render the steel weak, and the result is that it cannot stand the strain incident to contraction of one portion of the steel when another portion is hard and conse-

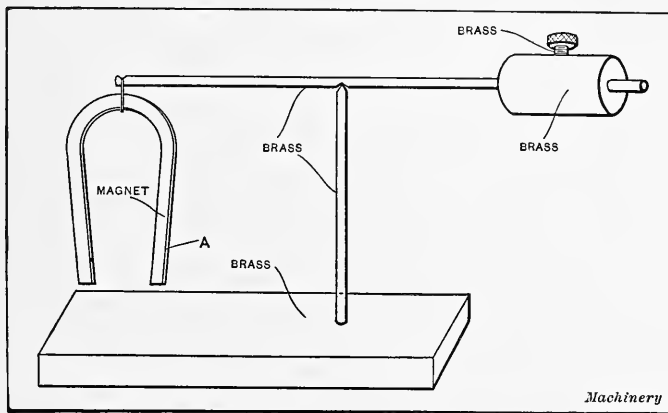

Fig. 26. Magnetic Device for Determining Correct Temperature for Hardening Dies

quently rigid and unyielding. Steel is strongest when hardened at the proper temperature, known as the "refining heat."

**Determining Hardening Temperature.** — A simple method of determining this refining heat, or the temperature at which the finest grain in the steel will be obtained, is illustrated in Fig. 26. The die to be tested is placed under the magnet *A*, from time to time, as the heating progresses, and when the point is reached where the steel has no attraction for the magnet, the die should be quenched in the cooling bath. If a temperature pyrometer is available, it is a good plan to record the temperature so that all dies made from this grade of steel can be heated to that point. If a temperature pyrometer alone is used, without the

magnet, readings are taken at stated intervals of approximately one minute apart, and then a chart is laid out by taking the readings as obtained from the pyrometer. This chart, if properly laid out, will show at the decalescent point or refining heat a horizontal line.

The temperatures at which decalescence occurs vary with the amount of carbon in the steel, and are also higher for high-speed steel than for ordinary crucible steel. The decalescence point of any steel marks the correct hardening temperature, and the steel should be removed from the source of heat as soon as it has been heated uniformly to this temperature. Heating the piece slightly above this point may be desirable, either to insure the structural change being complete throughout, or to allow for any slight loss of heat which may occur in transferring the work from the furnace to the quenching bath. When steel is heated above the temperature of decalescence, it is non-magnetic. If steel is heated to a bright red, it will have no attraction for a magnet or magnetic needle, but at about a "cherry-red," it regains its magnetic property. This phenomenon is sometimes taken advantage of for determining the correct hardening temperature, and the use of a magnet is to be recommended if a pyrometer is not available. The only point requiring judgment is the length of time the steel should remain in the furnace after it has become non-magnetic, as the time varies with the size of the piece. When applying the magnet test, be sure that the magnet is not being attracted by the tongs or other pieces of iron or steel.

While it is possible to harden steel within a temperature range of about 200 degrees and obtain what might seem to be good results, the best results are obtained within a very narrow range of temperatures which are close to the decalescence point. The hardening temperature for both low tungsten and carbon steel can be located with accuracy, and the complete change from soft to hard occurs within about a range of 10 degrees F. or less. Prior to heating, it is advisable to plug all holes for screws or pins with fireclay or asbestos. It is also good practice when planing a die blank to always remove at least  $\frac{1}{16}$  inch from

the top face of the die blank, as this amount is generally decarbonized and will not harden perfectly.

**Cooling Baths for Dies.** — Cold baths are a source of endless troubles when hardening dies. They will not make the steel any harder than one that is heated to a temperature of 60 or 70 degrees, or even warmer than this, but they will cause the die to spring or crack where the warmer bath would give excellent results. A bath of brine is to be preferred to one of water for this class of work, the brine being heated to the temperature mentioned in the foregoing. The following is a solution which has been found to give very satisfactory results for this purpose. Into pure rain water mix enough salt to float a raw potato. To eight gallons of the brine, add one pint of oil of vitriol. After hardening the die in this solution it should be dipped in strong, hot soda water, which will prevent it from rusting.

Have the bath of generous proportions. When the die is properly heated, lower it into the bath in a vertical position, moving it slowly back and forth in order to cause the liquid to circulate through the openings, thus insuring the walls of the opening hardening in a satisfactory manner. The backward and forward movement also brings both surfaces of the piece in contact with the liquid, causing them to harden uniformly, and preventing an undue amount of "humping," as would be the case if one side hardened more rapidly than the other. The workman must, of course, exercise common sense when doing this class of work. If he were to swing a die containing sharp corners, intricate shapes, and fine projections as rapidly in the bath as it would be safe to do were the opening round or of an oval shape, it might prove disastrous to the die, as such a shape would give off its heat very rapidly, and as a result the fine projections and sharp corners would harden much quicker than the balance of the die; as they continued to contract, the projections would fly off, or the steel would crack in the corners. To avoid this, have the bath quite warm, move the die slowly, and as soon as the portions desired hard are in the proper condition, remove the die and plunge it in a bath of warm oil, where it may remain until cooled to the temperature of the oil. Another

method of cooling a die so as to relieve internal strains is as follows: Plunge the die in the cooling bath and when it is sufficiently cold so that it can be taken hold of by the hands, withdraw it quickly and place it on the fire until it has become so warm that it will make water sizzle when dropped thereon; then immerse once more until cold. This is done to relieve the internal strains caused by hardening, and acts as a preventive of cracking. Most of the trouble experienced when hardening dies is due to one of two causes — possibly both. The first cause is uneven heating, the second, cold baths.

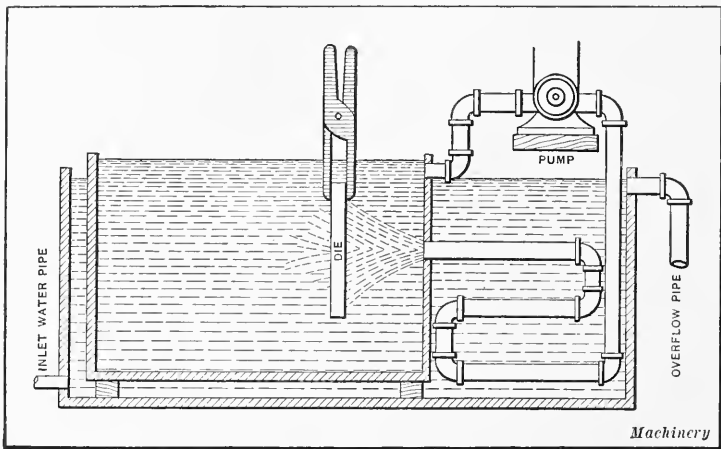

Fig. 27. Arrangement of Oil-cooling Bath for Dies

For dies which must retain as nearly as possible exact measurements, especially if of complicated form, pack-hardening gives excellent results. When hardening by this method, it is well to use a bath of raw linseed oil of the type shown in Fig. 27, in which the oil is kept from heating by being pumped through a coil of pipe submerged in a tank of water. If such a bath is not at hand, good results can be obtained, where the oil is not agitated, by swinging the die back and forth and moving it up and down in the oil. If many dies are to be hardened in this way, however, it is necessary to have a bath of generous proportions, or else several smaller baths, as it would not do to use the oil after it became hot, although oil that is heated

somewhat will conduct the heat from steel more rapidly than would be supposed, and is better adapted for hardening than if it is extremely cold.

**Drawing Temper of Die.** — A simple method of drawing the temper is to heat the hardened die (after the face has been brightened or polished) upon a heavy iron or steel plate, say,  $\frac{3}{8}$  or  $\frac{1}{2}$  inch thick; this plate should be set over the fire and the die placed upon it with the face upward. As the die becomes heated, it should be moved around the plate to avoid local and uneven heating. The color to which the die should be drawn before cooling depends upon the service for which it is to be used. For ordinary work it should be drawn to a deep straw color. The bottom and top surfaces should next be ground, preferably on a surface grinder, and if the hole in the die has been slightly distorted by the hardening operation, any slight corrections which may be necessary can be made by oil stoning.

**Points on Heating Die in a Forge.** — Manufacturing plants are not equipped with all the latest and most approved facilities for hardening, if there are only a few pieces to be treated occasionally, and, in cases of this kind, the diemaker must make the best of the apparatus on hand. If a blacksmith's forge is used, let the die be placed in the fire with the cutting face upward. During the period of heating, keep the fresh coal away from the die by surrounding it on all sides and on top with red-hot cinder coal. When turning on the blast, be careful not to give it too much air. The more sparingly the blower is used, the better are the chances of the steel becoming evenly heated throughout. Turn it into the fire for about a minute, then shut it off and let the heat *soak* into the die instead of *blowing* it in. This is probably the most important point. The block of steel must be evenly saturated with heat and kept from contact with cold air until it reaches the proper hardening temperature. Remember to blow a little and then stop the air while the steel absorbs the heat. While the die is being heated, prepare a pail of clean water, taking the chill from it, that is, heating it until lukewarm. The die, held in one hand with tongs, is then plunged into the water and kept moving all the time; when the

die is cool enough, take hold of it with the other hand and stir the water with it until both water and die arrive at the same degree of heat. Now instead of taking the die out of the water and reheating it over the fire or letting it cool in the air, just let the water and steel cool off together.

**Hardening Punches.** — If punches are to be hardened — and this is generally considered best — they should be very carefully heated. It must be borne in mind that punches are subjected to a great strain; consequently, they should be heated uniformly, and to as low a temperature as will give desired results, thus making them as strong as possible. Heat slowly to avoid *overheating* the corners, as these are subjected to the greatest strain. The distance a punch should be hardened depends on the shape and size, and the use to which it is to be put. If it is a piercing punch that is long and slender, it should be hardened the entire length to avoid any tendency to bend or upset when in use. If it is of a form that insures sufficient strength to resist any tendency to upset when in use, then it need not be hardened its entire length. A simple method of hardening a punch to prevent warping, which is recommended by an expert diemaker, is as follows: The face of the punch for about  $\frac{3}{4}$  inch up is held in molten lead until it is an even red color all over. It is then quenched. This hardens the face of the punch for about  $\frac{3}{4}$  inch up and leaves the back soft. This method has very little tendency to warp the punch, the large part of it, which is cold, or comparatively so, counteracting it. Experience has shown that if properly done, the punch comes out straight and parallel and not warped at all.

Pack-hardening is an admirable method of hardening punches for most work, but for piercing punches, it is not recommended, as the whole structure of the steel should be as nearly alike as possible. Such punches should be heated in a muffle furnace, or in a tube in the open fire, turning the work occasionally to insure uniform results, for not only can we heat a piece more uniformly if it is turned several times while heating, but a fact not generally known is that a cylindrical piece of steel heated in an ordinary fire without turning while heating will many



times show softness on the side that was uppermost in the fire, no matter what care was taken when heating and dipping. If it is reheated with the opposite side uppermost, *that* will be found soft if tested after hardening, while the side that was soft before will be *hard*. The smaller the punch the more attention should be given to the condition of the bath. Luke warm brine is the best. Work the punch up and down and around in the bath.

**Tempering Punches.** — It is the practice of many diemakers to draw the temper of comparatively long slim piercing punches to a full straw on the cutting end, but to have the temper lower further up the punch. Better results follow, however, if the punch is left of a uniform hardness throughout the entire length of the slender portion, as it is then of a uniform stiffness, and the liability of springing, especially when punching stiff or heavy stock, is reduced to a minimum. It is generally considered good practice to temper the punch so that it is somewhat softer than the die; then, if from any accident the two come in contact, the die will in all probability cut the punch without much injury to itself. There are exceptions to this practice, however. In many shops where large numbers of dies which are hardened are used, it is customary to have the one which is the more difficult to make the harder, so it will cut the other if they come in contact with each other.

Punches should be carefully examined after hardening and tempering, and those which have been bent or sprung in the hardening should be carefully straightened. Piercing punches in compound dies are steadied by the knockout while operating on the stock. The punch is made a sliding fit in the knockout, and the knockout is also made a sliding fit in the die. When perforating thick metal where the strain on the press is great, a good method to reduce the pressure is to make each second punch lower than the preceding one an amount equal to the thickness of the stock. This, as can be seen, will reduce the pressure, as half the punches are through the stock before the remaining half operate. When heavy stock is being blanked or pierced, punches are not required to fit as snugly as when the metal is thin.

It is generally found after hardening small piercing punches, that although the holes in the punch-holder are true with the die, the punches do not line up. This is because they have bent slightly in hardening. They can usually be brought into alignment by giving those that do not enter half a turn, but if this does not locate them correctly, they should be removed and straightened. When a large and a small piercing punch are too close together to allow of both being set in the punch-holder, the smaller punch is set in the larger one, and securely held in position.

**When Punch and Die should be Hardened.**— There are various opinions among practical men as to the advisability of hardening punches. For most jobs it is the custom to do so, though there are some mechanics who consider it advisable to harden them, and others who do not. There are instances where punches work well either way, and in such cases it is, of course, a matter of opinion. The blanking or cutting dies used on comparatively thin stock, such as tin, brass, aluminum, iron, steel, copper, zinc, etc., are ordinarily hardened and tempered to suit the work, and the punch is left quite soft, so that it can be “hammered up” to fit the die when worn. This practice is followed in some plants for all metals less than  $\frac{1}{16}$  inch thick which are not harder than iron or very mild steel. After the end of the punch has been upset by hammering, the punch and the die are oiled and forced together, which causes the hard die to shave the punch to a close fit. If the die is dull, it should be sharpened prior to this shearing operation. For some classes of work, the punch is made hard and the die soft. Both the punch and die should be hardened when they are to be used for blanking thick iron, steel, brass, or other heavy metals.

**Correcting Mistakes made in Dies.**— Should the workman, through misunderstanding or carelessness, make the opening in a die too large at any point, he should not attempt topeen the stock cold, as is sometimes done, for while it is possible to do this and then finish the surface in such a manner that it will scarcely be noticeable, the stock directly below where the peening took place will almost surely crack during the life of the die. Should

the mistake referred to occur, heat the die to a forging heat, when the stock may be set in without injury to the steel. When setting in, a blacksmith's fulling tool may be used; this is placed on the face of the die and struck with a sledge. If there is objection to disfiguring the top surface of the die, this method cannot, of course, be used. It is never good practice to bend, set in, or otherwise alter the form of steel when cold, if it is to be hardened, as such attempts nearly always end in a manner entirely unsatisfactory.

**Reworking Worn Dies.** — When a die becomes worn so that the opening is too large, or the top edge of the walls of the opening are worn so that the die is "bell-mouthed," it may be heated to a forging heat, set in with a fulling tool, or a punch of the desired shape, after which it is reheated to a low red and annealed. After annealing it is reworked to size. This reworking, if care and judgment is used, gives excellent results, and effects a considerable saving, as otherwise it would be necessary to make new dies, while the die may be reworked at a fraction of the expense of a new one.

When making a sectional die, it is possible, in case the opening is a trifle too large, to work a little stock off the faces that come together, provided the outer edges have not been planed to fit the holder; also, if it is allowable, these surfaces may be cut away the desired amount, and a strip of stock of the proper thickness placed between the die and holder. Considering the liability of a mistake taking place when a beginner is doing work of this kind, it is, generally speaking, advisable to leave the fitting of the die to the holder until the opening has been worked to size.

**Stripping Stock from Punch.** — When punches are operated on sheet stock, the latter will be carried upward when the punch ascends, unless there is some device to prevent this. The simplest arrangement for stripping the stock from the punch and one that is applied to most blanking dies, consists of a plate which is attached to the die (as illustrated in Fig. 1, Chapter I), and has an opening for the punch to pass through. Beneath this stripper plate there is a passage-way or opening through which the stock is fed. Obviously, the space between the die

face and stripper plate must be greater than the thickness of the stock to permit the latter to be fed along easily. As the result of this play between the stripper plate and die the stock is distorted to some extent by the action of the punch. This distortion, in many cases, does not cause trouble, especially when the die simply cuts out plain blanks, but when a follow die is used and flat accurate blanks are required, or when the operation is that of piercing a number of holes in sheets or flat plates, it is often necessary to hold the stock firmly against the die while the punches pass through it, in order to prevent any wrinkling or buckling.

**Stripper Attached to Punch.** — One method of preventing the stock from being wrinkled or distorted by the action of the punch is illustrated in Fig. 28. The stripper plate *M* is fastened to the punch-holder instead of to the die, and it is backed up by a stiff coil spring at each corner. On the downward stroke of the press, the stripper plate presses the stock firmly against the die, holding it level while the punches perform their work. The stripper is so located that the punches do not come quite flush with its lower face, so that the stock is subjected to pressure before the punches come into action. As the stock is fed through the die it is guided by means of small pins *N* at each end of the die. The stripper should not fit the punches closely because if the operator should make a miscut or if a piece of scrap punching should get under the stripper, it would cause it to tilt and probably break the small punches. With a die of this type the difficulty connected with wrinkled work is overcome. On the other hand, when a follow die is made with a fixed stripper of the usual form, the work is distorted somewhat, so that the location of pierced holes relative to the outer edges of the blanks is not always sufficiently accurate. As the die illustrated in Fig. 28 was made without guide pins for holding the punch and die in alignment, straps *S* were used to hold up each end of the stripper plate in order to expose the ends of the punches when aligning them. These straps were used by forcing the stripper upward and inserting the ends of the straps in the holes *T*, as indicated by the detail view.

**Presses with Cam-actuated Strippers.** — Owing to the tendency which stationary stripper plates attached to dies have to distort pierced sheets, etc. (as explained in the foregoing), some presses are equipped with cam-actuated stripper plates. The stripper plate is attached to vertical rods which extend up above the press slide. When the press is in operation, the stripper, which is actuated by cams on the press shaft, descends first and clamps the stock before the punches enter the work. As

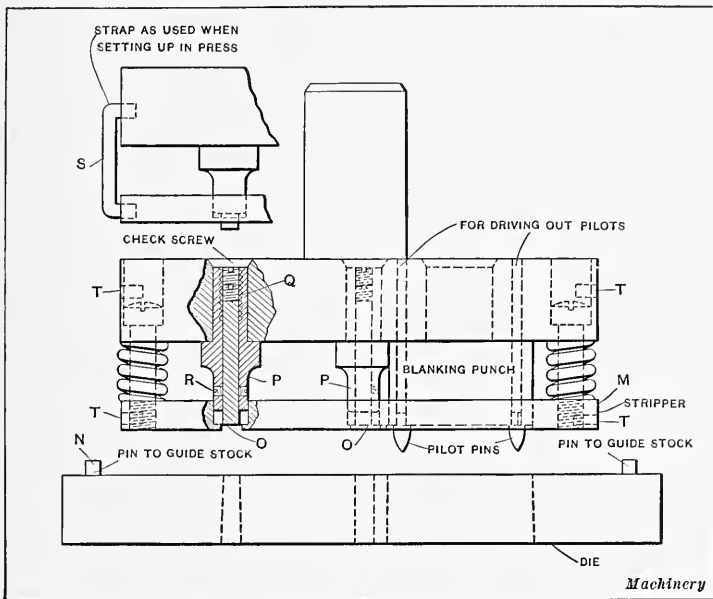

Fig. 28. Stripper Attached to Punch to Flatten out Stock and Hold it Securely

the stripper plate is suspended above the die, a clear space is left between the punch and die, so that the operator has an unobstructed view. The stripper plate moves up and down with the punches, so that the latter may be made shorter than would be possible with a stationary stripper, thus increasing their rigidity and durability.

A smaller hole in proportion to the thickness of the stock may be pierced when using a stripper of this kind, because of the close support which the stripper gives the punches up to the

point where they enter the stock. Another advantage connected with the use of the cam-actuated stripper is that of avoiding the blow from the stock which the lower side of the stationary stripper plate receives upon the upward stroke of the punch, owing to the necessary play between the die and the stripper plate. This method of stripping the stock is particularly adapted for gang punching and perforating operations, especially when the punches are small in proportion to the thickness of the stock and when it is essential to guide them close to the surface of the work.

**Pilots or Guide Pins for Punches.** — The pilots or guide pins which are placed on the ends of some punches for aligning the stock before blanking, by entering holes that have been pierced previously, should be made slightly smaller than the hole in the blank and should be straight for the thickness of the stock, and then rounded off similar to the point of an acorn. The heads of all guide pins should be turned true with the shank. Care should be taken to see that the guide pins are also exactly in line with the pierced holes. If they are not in line they have a tendency to twitch the metal around, so that after a few blanks have been punched, the strip will not be in alignment with the die. Precaution should be taken to see that the stock does not cramp between the guide pins and the stop, or between the guide pins and the back gage, because if this is neglected it will generally cause trouble. When the pierced holes are very small the punch should be provided with a spring guide pin, so that if the pin misses the pierced hole in the blank, it will spring back into the punch and nothing is spoiled except the blank. After having completed the die and punch, before taking them to the press, see that all guide pins, when in the punch, locate accurately in the pierced holes, and also see that all the punches line up perfectly.

**Punch Troubles and Remedies.** — Small perforating punches which have annular marks left on them from turning or polishing are much more liable to fracture than those having marks which run parallel with the punch, especially when perforating heavy stock. This is due to the fact that the metal presses

into the minute lines or grooves, thus increasing considerably the force required for stripping. As is generally known, most punches when used on heavy metal are broken while stripping the stock and not while perforating it; therefore, the stripping should be made as easy as possible. The stripping can be facilitated by making the punch slightly tapering towards the top, although this is not practicable for small punches, because the strength of the punch would be reduced too much. When the face of a punch which is used on heavy metal tends to chip off, it is caused either by the punch being too hard or the diameter of the die hole being too near to the diameter of the punch. If the stripper plate is not parallel with the die, this will also cause broken punches. Even though the error in alignment is small, the constant bending action that the punches must undergo every time the stock is stripped tends to shorten their life. Sometimes the stripping is much harder on one end of the die than on the other, because more holes are perforated at one end. In such a case, special care should be taken to see that the stripper plate starts the stock from the punches evenly and uniformly. The making of small perforating punches requires attention to minute details in order to secure the best results. For instance, a punch should not be made with sharp corners but rather with rounded corners. It should never be undercut, because even if it is scored very slightly this will establish a breaking point.

When a die has a number of large and very small punches, it is often advisable to make the large ones long enough to perforate the stock and just enter the die before the small ones touch the metal, especially if the stock is heavy, because the jar resulting from the action of the large punches may shift the stock slightly which would tend to break the smaller punches, provided they entered the stock at the same time. This method of varying the lengths of punches has often been used to advantage in dies having a large number of punches, and has made it possible to use a certain press which otherwise would have lacked the necessary capacity, inasmuch as the pressure required for punching is distributed somewhat. When locating

punches in the holder, one of the principal points to consider is that the stripping strain should be as equally divided in relation to the punch-holder shank as possible; the surface of the holder which bears against the slide of the press should also be of such a size that the face of the slide will not be injured. Punches often shear themselves because a depression has been worn in the face of the slide and for that reason the holder is not properly supported. Inaccuracies in laying out pilot holes in punches and the use of eccentric pilots in order to make them register properly have also been the cause of much spoiled work. The trouble is that when the punch is sharpened, this necessitates the removal of the pilot which often is not replaced in the same position, and, consequently, it does not engage properly with the pierced holes in the stock.

It sometimes happens that the blanking punch or certain perforating punches are of such a shape that they tend to incline to one side and cause shearing when passing through the metal, thus injuring the edge of both punch and die. This is caused by the shearing thrust not being equal on all sides. For instance, the shearing strain from two long sides sometimes crowds the punch over toward the shorter side. To prevent this trouble the face of the punch should be ground to a slight angle so that it enters the shorter side first; then this side will be backed up by the die to take the thrust when cutting the remaining part of the blank.

**Points on Making Compound Dies.** — Compound dies are made without clearance, and the blanks are ejected by the knockout as soon as the punch leaves the die. The piercing holes in the punch, however, should be taper reamed and larger at the top, so that the piercings will pass up through the punch easily. The throwing out of the piercings from a compound die is aided by setting the die in an inclined press. If a double compound die is required to produce two blanks on one stroke of the press, care should be taken to see that the knockouts are ground to the same height, and also that the blanking punches are perfectly level, so that both blanks will be flattened alike. The spring or rubber pad which operates the knockout in the



compound die should be adjusted tighter than necessary to insure the blanks being removed. The knockout should just bring the blank to the surface of the die.

**Stop-pins for Dies.** — The stop-pin on a die is a device for controlling the position of the stock as it is fed through for each successive stroke of the press, so that the spacing of the openings cut into the stock will be uniform and a predetermined distance apart. The design and adjustment of stop-pins for blanking dies is an important branch of die work that affects both the quality and the quantity of the output of the press. There are many different types of stop-pins, such as the plain fixed stop-pin; the bridge stop-pin; the simple latch; the

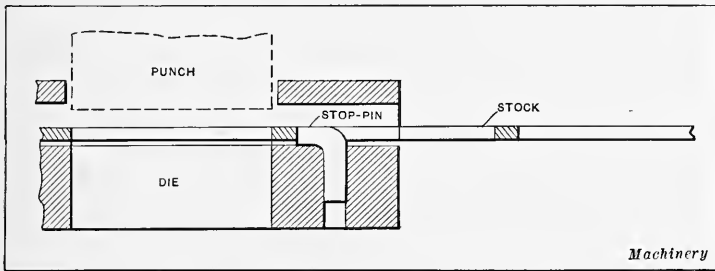

Fig. 29. A Plain Fixed Stop-pin

spring toe latch; the side swing latch; the positive heel-and-toe latch, etc.

These devices, with the exception of the first, can be used with either hand feed or automatic roll feed. The ideal output of one blank for every stroke the press can make in a day is never realized with single dies, and delays which arise from many sources have to be studied carefully and eliminated so far as they contribute to unnecessary expense. In addition to improper design and poor adjustment of the stop-pin, other causes of small output are: lack of skill; inconvenient arrangement of the new stock, the blanks and the scrap; inefficient methods of oiling the stock; and poorly made or poorly designed dies. A skillful operator will usually arrange the stock distribution quite well, but the design and adjustment of the dies and the stop-pin usually devolve upon the toolmaker.

**Plain Fixed Stop-pin.** — The plain fixed stop-pin, which is the simplest type, is indicated in Fig. 29. With it the operators become so expert that they are able for several minutes at a time to utilize every stroke of a press making 150 revolutions per minute. This stop is best suited to the use of strip stock in simple dies, because a miss will then cause no serious delay. The time between finishing one strip and starting the next affords the necessary rest for the operator. The concentration required is very intense — especially for the novice. When but

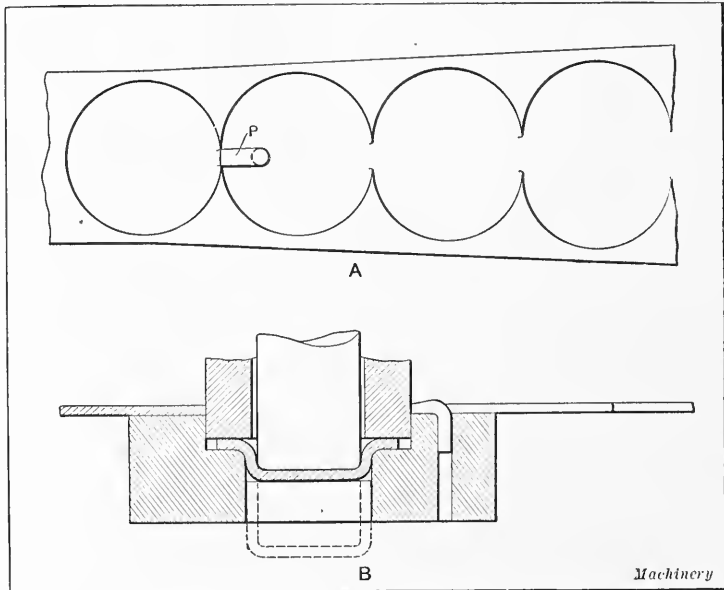

Fig. 30. (A) Fixed Stop-pin Set close to Blanking Die Opening. (B) Example Illustrating Application of Stop-pin Set as Shown at A

a few blanks are made from a die at one time, and when changes of dies are frequent, this simple stop-pin is the most economical. Of course, it would not be feasible to use this stop-pin for coiled stock and expect the operator to finish the coil without a rest or a miss. There is, however, one method of using this stop which permits of a maximum output; that is to allow no metal between the blanks. Then the stop-pin will extend clear up to the die and be high enough so that the stock cannot jump it. Each blank will then part the scrap at the stop-pin and allow

the stock to be pulled along to its next position. This arrangement is shown at *A* in Fig. 30, with the stock parting at the pin *P*. This method is widely used on simple work where the edge of the blank does not have to be perfectly uniform. Small drawn cups are made in this way. The blank is cut by the first punch and held by it while a second punch, within the first, draws the blank through another die and forms the cup. This is shown in Fig. 30 at *B*. The stock feeds to the right and each cup, as formed, pushes the one ahead of it through the die

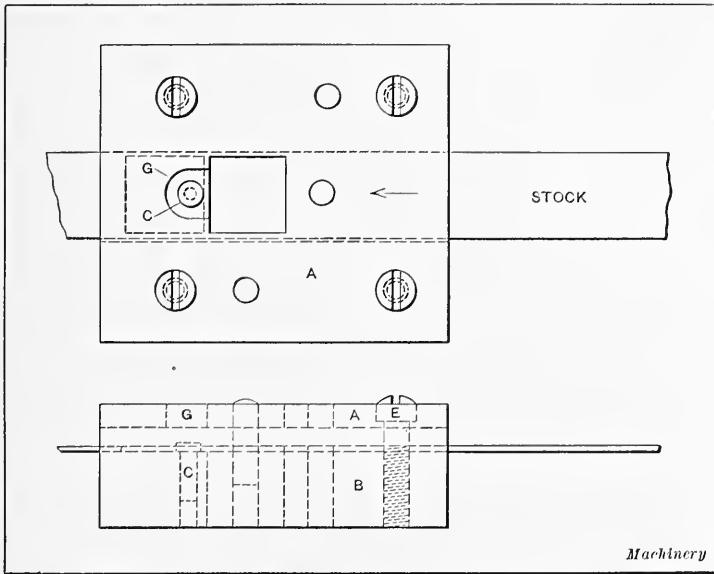

Fig. 31. Improved Form of Fixed Stop-pin

as indicated by the dotted lines. Where the die has least to cut it will wear away most on account of the thin pieces of stock that crowd down between the punch and the die.

The common way to make a fixed stop-pin is to bend over a piece of steel rod and drive it into the die. The difficulties and disadvantages connected with making a bent stop-pin are as follows: First, the difficulty of bending the pin at right angles without breaking it or bending the part to be driven into the die; second, after the pin has been made and hardened it is apt

to break in driving it home to its place in the die because of its uneven shape; third, in driving the pin into the die it is liable to swing around out of its proper position, making it necessary to knock it around again and thus increasing the chances of breaking it. Every time the die is ground, this difficulty is experienced and the result is frequent breakage and consequent loss of time in waiting for new stops. All these difficulties are overcome by making the style of pin shown in Fig. 31. This is simply a shoulder pin turned to a nice snug fit in the die. The shoulder, which acts as the stop for the stock, may be made larger

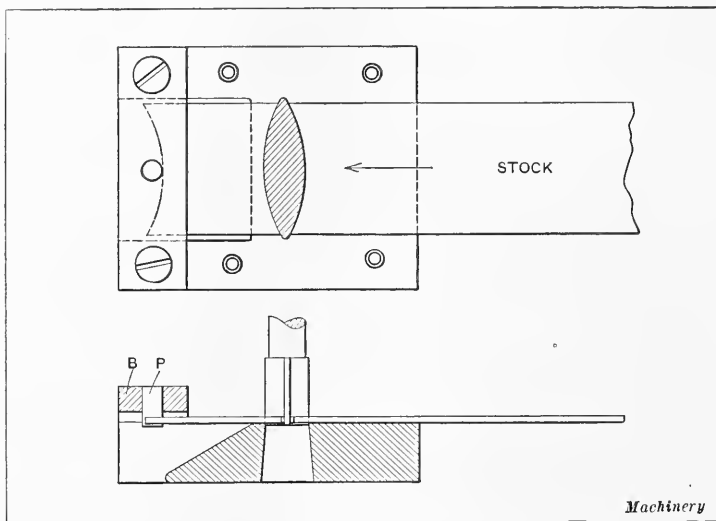

Fig. 32. Stop-pin of the Bridge Type

or smaller in diameter according to the width of scrap desired between blanks. This stop is quickly and easily made, is easily taken out and put back again after grinding the die, and will last as long as the die itself. It is a good idea to cut a hole through the stripper *A* directly over the stop-pin as shown at *G*, so that the operator can see the pin when the press is in operation.

**Bridge Stop-pin.** — The bridge stop-pin, shown in Fig. 32, is easy to operate and simple in design. The stop-pin *P* projects downward from a bridge *B* that extends over the stock which

is fed to the left. Provision is made for the blank (or scrap, as the case may be) to fall out under the bridge. The use of this type of stop-pin is limited to that class of work which cuts the stock clear across and uses its edges as part of the finished blank. As here shown, the scrap is being punched through the die, and the blank, when cut, falls down the inclined end of the die. When the blanks are simpler and have straight ends, the die may be so arranged that each stroke finishes two blanks, one being punched through the die and the other falling outside down the incline. Little skill is required of the operator; he simply has to be sure to push the stock up to the stop-pin at each stroke.

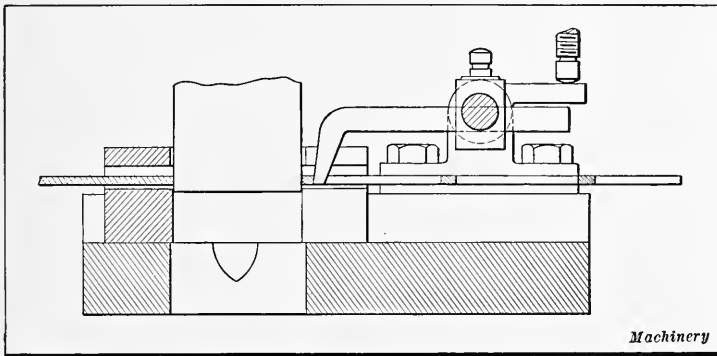

Fig. 33. Simple Latch Form of Stop

**The Simple Latch Form of Stop.** — The simple latch is shown in Fig. 33. It is suited for dies that have pilot-pins. The latch is lifted by the down stroke of the punch and is lowered again as the punch rises. Hence it is evident that, if used with dies without pilot-pins, the punch must reach the stock and hold it before the latch lifts. When its lifting is thus delayed it will lower before the punch withdraws from the stock and will fall in the same place it lifted from so that the stock cannot be fed along. On the other hand, if a pilot-pin is used, which enters the guide hole just before the latch lifts, the latch may be set to lift before the punch reaches the stock. It will then fall after the punch withdraws from the stock, and sufficient time may be allowed for the operator to feed the stock along. This device is

best suited for use with automatic feed rollers because the timing of the operations is uniform; if the operator does not pull the stock with uniform speed the latch is apt to drop too soon or too late. Another manner of operating this simple latch is to give it its motion by means of a cam or eccentric on the press shaft. When thus driven its motion can be very carefully timed, irrespective of pilot-pins. This style is also best suited for automatic roll feed. New presses are often provided with this attachment.

Another simple form of latch which differs somewhat from the

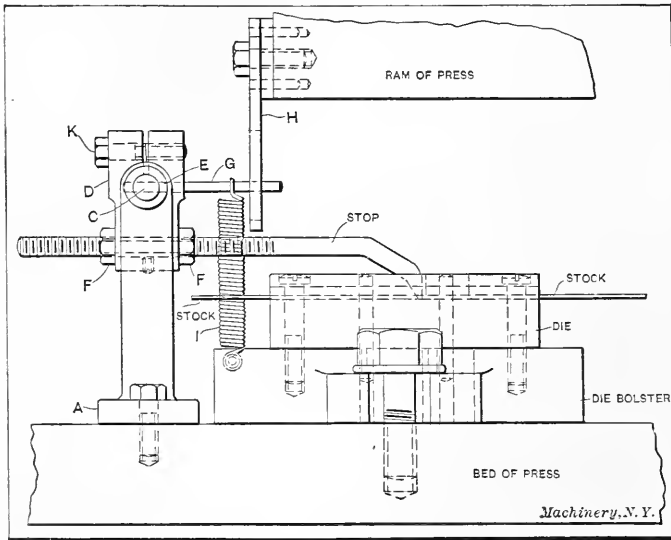

Fig. 34. Latch which is Operated by Slotted Arm Attached to Punch

one just described is illustrated in Fig. 34. There are two brackets *A* which form bearings for rod *C*. The stop is attached to rod *C* by a split knuckle *D*, this knuckle being held to the rod by means of the cap-screw *K*. Two washers *E* are fastened to each end of the rod on the outside of the brackets, to obviate any longitudinal movement, but allowing it to rotate easily. The stop can be adjusted through the knuckle *D* by means of the adjusting nuts *F*. The manner in which this stop operates is as follows: As the ram of the press ascends, the arm *H*, which is fastened to the ram, as shown, and has a longitudinal

slot in it, raises the pin *G*, which extends through the rod *C*. As this pin is lifted it rotates the rod *C* and, consequently, raises the stop against the tension of spring *I*. When the stop is raised, the feed-rolls force the stock through the die, but the stop descends before the stock has been fed the required distance. The feed used is the ordinary ratchet feed and is set so that it feeds  $\frac{1}{16}$  inch further than the required distance to compensate for any slip, such as often takes place in ratchet feeds which are used for punch and die work.

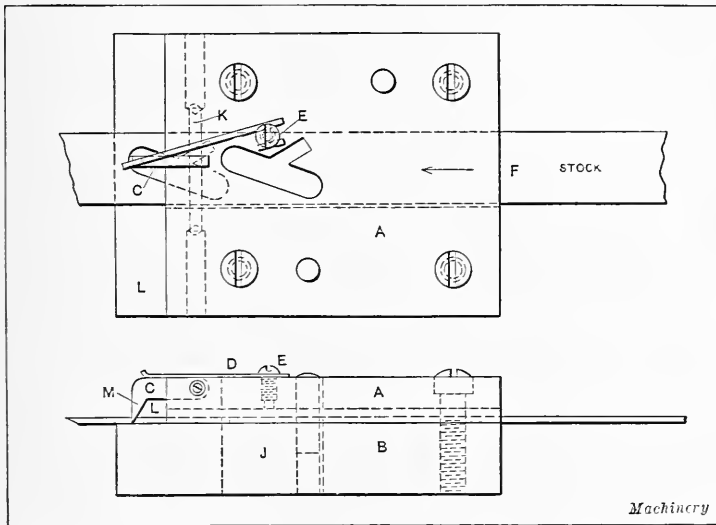

Fig. 35. Latch Stop which is Operated by Feeding Movement of Stock

**Latch Stop Operated by Stock.** — The stop shown in Fig. 35 is excellent because of its simplicity, and also because of the great variety of work to which it may be applied. This stop is of the latch variety, but it differs from most stops of this type in that it requires no mechanism to lift it. It is not operated by the action of the press nor by the punch, as is generally the case with latches. A hole is drilled through the stripper *A* to receive the pin *K* which passes through a hole in the stop *C*. The stop swings upon this pin. A light flat spring *D* is fastened to the top of the stripper so that the end of the spring rests on top of the stop. In securing this spring to the stripper, it is only

necessary to place one end under the head of the screw *E* with a piece of the same material under the opposite side of the screw as shown in the plan view. By this method the spring can be quickly and easily attached or removed, and a straight piece of spring material can be used. The stripper should be cut off at the stop end as shown at *L* so that the stop will be outside of the stripper and in full view of the operator.

The action of this stop is as follows: The stock *F* is fed to the left, and as the punched strip passes the stop, the point of

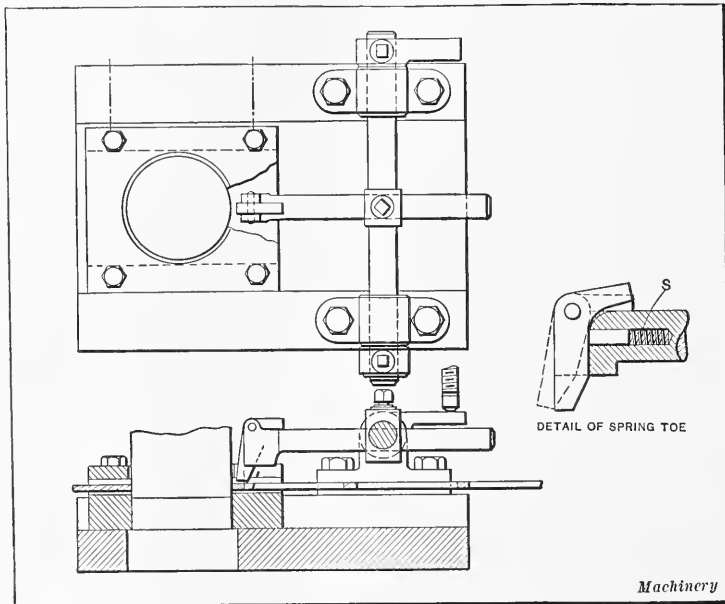

Fig. 36. Spring Toe Latch Stop

the stop *M* drops or rather springs into the hole made by the blanking punch. The operator then pulls the strip back against the straight outer edge of the stop, and holds it there until the next blank is punched. This process is repeated at each stroke of the press, the scrap between the blanks being pushed past the stop each time and then pulled back against it. The inner beveled edge of the point *M* causes the stop to lift as the scrap between the blanks is pushed against it, while the outer edge, which is at right angles with the die, prevents the stop from



lifting when the edge of the scrap is pulled back against it. It will be evident from this that a double movement is required, *i.e.*, to first push the stock ahead more than the required distance and then pull it back into contact with the stop.

An operator can make about 40,000 blanks per day with dies fitted with this form of stop on a press making about 100 strokes per minute. These stops are used only on hand-fed work.

**The Spring Toe Latch.** — The spring toe latch involves but little change from the simple latch. Fig. 36 shows it clearly with an enlarged detail of the spring toe. This latch may be used very successfully with hand feed and there is little danger

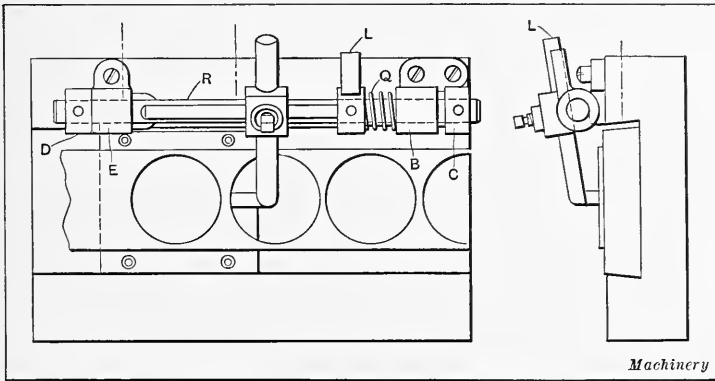

Fig. 37. The Side Swing Latch Stop

of the stock getting by it too fast. Its operation is as follows: As the punch lowers and starts to cut the blank, an adjustable screw on the ram or punch plate lifts the latch. Its spring toe snaps forward and when the latch lowers, it rests on the scrap left between two blanks; hence it cannot fall back into its former place. When the operator pulls the stock along, the latch toe drops into the next hole and brings the stock to a stop at the proper point, compressing the light spring *S* as it does so. This design is simple, rigid and effective. The spring toe here shown is preferable to the design described in the following because it is light and requires but little tension on the stock to bring it to a stop.

**The Side Swing Latch.** — The side swing latch shown in Fig. 37 is but a modification of the latch shown in Fig. 36. When the punch descends, an adjustable screw hits lever *L* and lifts the latch. The whole rod *R* then springs forward till collar *C* stops against *B*. When the latch lowers it rests on the stock

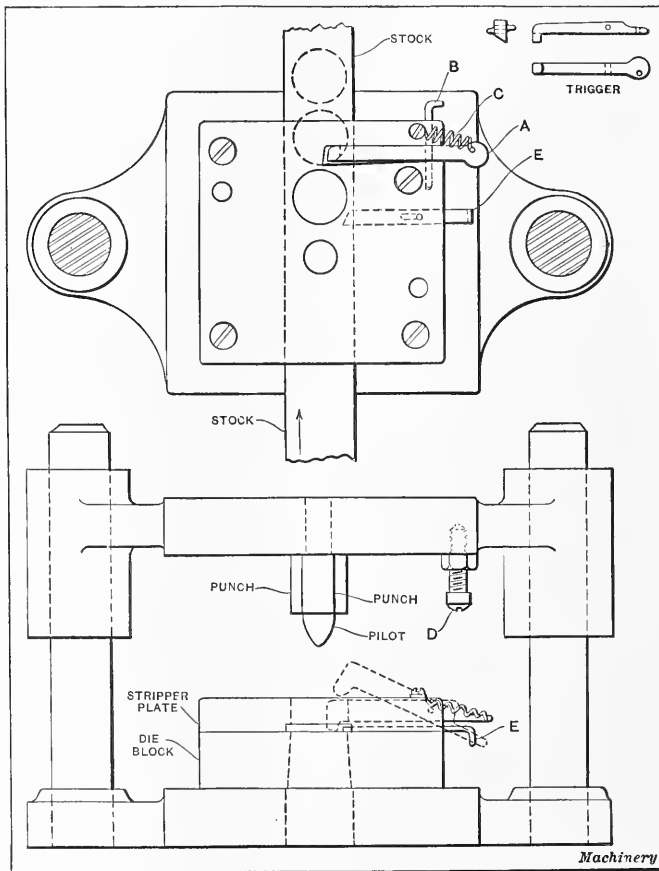

Fig. 38. Another Stop of the Side Swinging Type

as did the spring toe latch. As the stock is pulled along, the latch drops into the next hole and acts as a stop again. With this style of latch the tension on the stock must be greater than with the spring toe latch, because the whole rod *R* has to be pulled along against the spring *Q* until collar *D* engages stop *E*.

If this design were modified, however, so that the side bearings were used only for allowing the latch to swing, the toe could be constructed like the spring toe latch and would then be quite as effective as this type, though not so rigid.

Another design of side swinging latch is shown in Fig. 38. This stop mechanism consists of a latch or trigger *A* which is pivoted on the pin *B*. The latch works in a tapered slot in the stripper plate which allows it a sidewise movement of about  $\frac{1}{32}$  inch. A helical spring *C* pulls the point of the latch down and tends to hold it on the side of the slot nearest to the advancing stock. A trip-screw *D* is screwed into the upper member of the die directly over the latch, and is so adjusted that it will cause the point of the latch to be raised as soon as the punch has started operating on the stock. The method by which this mechanism operates is as follows: When the stock is pushed forward against the latch, the latter is moved over to the far side of the tapered slot and the stop locates the stock in the required position for punching. As soon as the punch engages the stock, the trip-screw *D* strikes the latch and raises its point out of contact with the stock; then the spring *C* pulls it to the opposite side of the tapered slot so that when the punch rises and the latch is allowed to drop, the point comes down on top of the stock instead of in the hole produced by the blanking operation; consequently, the stock can be pushed forward until the stop drops into the next hole and the movement of the stock is then continued to the position for the next punching operation. The point of the latch is beveled at the back to provide for withdrawing the stock if necessary. The sliding stop *E* is placed in the stripper plate to locate the end of the stock in the proper position for the first operation with progressive blanking dies.

**Positive Heel-and-toe Latch.**— While the swinging latch type of stop-pins relies on gravity or a spring to bring them back in position, the heel-and-toe latch is positively operated. Its distinctive feature, which recommends it for use on a large variety of work, is that it is impossible for the stock to slip by it faster than one blank per stroke of the press. This is a very

important matter when combination or gang dies are being used, because of the pilot-pins on the punches. If the stock slips too far, the guide holes, previously pierced, pass beyond the pilot-pins, and when the punch descends, the pilots punch their own holes, throw down a heavy burr, and cause a delay — if nothing more serious.

The upper view in Fig. 39 shows the catch in position to stop the movement of the stock at its point *A*. The stock is being fed to the right. The conical-pointed pin *B* is pushed by the spring *S* so that it engages a conical depression *C* in the end of

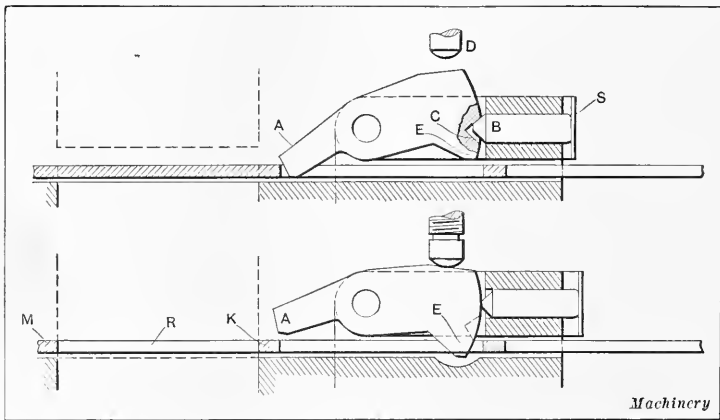

Fig. 39. Positive Heel-and-toe Latch which Prevents Stock from Moving more than One Blank for Each Stroke of the Press

the catch. By this means the toe of the catch is pressed against the die. As the punch descends to cut the next blank, an adjustable screw on the punch plate presses on the top of the catch at *D* and causes the heel to lower and the pin *B* to disengage from the notch *C*; the position of the latch is then as shown in the lower view. Its heel *E* has been lowered into the hole left by the previous blank and it is held in this position by the pressure of the point of *B*. While this is sufficient to hold the catch in its new position, it offers but little resistance to its return to the original position. The stock may now be moved along. The metal *K*, left between two successive blanks, engages the heel *E* of the latch and lifts it easily. This causes the notch *C* to engage with the pin *B* and the catch snaps back into

its first position. The toe *A* falls into the new opening *R*, and *M* comes to a stop against it. Since the metal *K*, between two successive blanks, cannot pass the heel of the latch without raising it, and since the heel *E* cannot rise without lowering the toe *A* far enough to catch the stock, it is evident that the action is positive; hence the stock cannot jump ahead faster than one blank at a time.

In constructing a stop of this kind, care must be taken to allow under the heel *E* but little more height than the thickness of the stock. The length of the catch from toe to heel should be less than the opening left by one blank; then there will be no difficulty in starting the new ends of strips or coils. If necessary, however, the catch may be made so as to measure a little less than two (or more) openings in the stock. In such a case the catch would have to be tripped by hand until the first piece of stock *K*, between two blanks, had passed under the heel *E*. This would cause delays which would amount to considerable in the case of strip stock.

This style of stop has been used successfully with gang dies cutting blanks from brass  $\frac{1}{32}$  inch thick, and cold rolled steel  $\frac{1}{16}$  inch thick. In the case of the steel blanks, reels were used and the scrap was wound on a reel as it came from the die. By keeping the proper tension on the scrap, the stock was pulled through the die and kept against the stop. Four thousand blanks per hour were made by this means. In view of the thin stock used and the fact that the dies were of the combination type, this was considered very good. The stop had to be set accurately because the thin stock prevented the pilot-pins from shifting it much when aligning. Other precautions taken on account of the thin stock were to make the toe broad and to fit the stripper close to the front edge of the toe.

**Starting Stop for Follow Die.** — The devices so far described serve to stop the stock when it has passed the blanking punch, but there are many cases where two or more operations are performed on a piece before it reaches the blanking die and the usual stop-pin. The operator usually gages the proper positions by watching the end of the stock through openings in the stripper,

but it is better to have temporary stop-pins that can be used for that purpose. Fig. 40 shows a starting device for a follow die with two punches. When starting a strip the button *B* should be pressed. This brings into action the temporary stop *S*, which locates the stock properly for the first operation. It is then released and springs back out of the way. The stock is then advanced to the regular stop-pin. As many of these side stops may be used as are necessary. Not only do they save annoyance and time, but they add to the life of the dies by preventing the partial cuts due to the stock entering too far at the start.

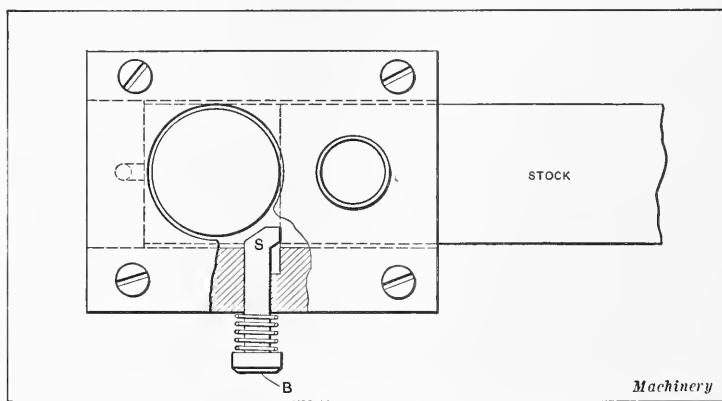

Fig. 40. Stop for Starting Stock in a Follow Die

**Position of the Stop-pin.** — The exact position of the stop-pin or that part of the pin which engages the stock depends, of course, upon the lay-out of the die and the amount of stock that is to be left between the punched holes. The width of this strip or bridge *w* (see sketch *A*, Fig. 41) between the punched hole is usually approximately equal to the thickness of the stock; it should not be less than this amount and for very thin material should exceed the thickness slightly. When there is not sufficient stock between the openings, the punch, which tends to draw the material in when passing through it, may actually draw it to such an extent as to cause damage. While it is common to allow the thickness of the stock, this rule should not always be applied. For instance, when narrow strips,  $\frac{1}{4}$  inch

wide by 3 inches long, were blanked out crosswise of the strip, it was found that by allowing only the thickness of the metal the punch sheared off toward the scrap side because the end cuts were so narrow that they did not support the punch against the thrust resulting from the shear on the solid side of the strip. When using dies of the general shape referred to, it is advisable to allow at least  $1\frac{1}{2}$  times the thickness of the stock between the blanks.

The position of the stop for a simple blanking die may be de-

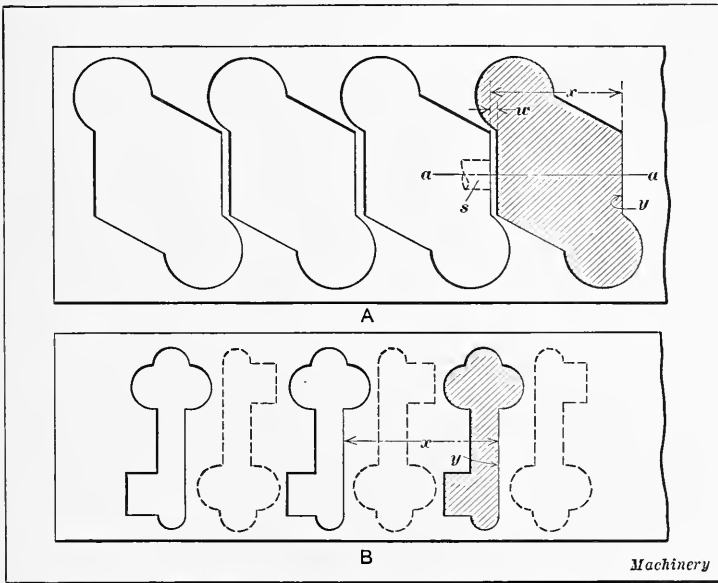

Fig. 41. Diagrams Illustrating how Location of Stop-pin may be Determined

termined as follows: Draw outlines representing the two holes that are punched successively, so that they occupy the same relative positions as required for the holes in the stock; then draw a line parallel to the edge of the stock as at  $a-a$  and measure the distance along this line between corresponding points on the outline, thus obtaining dimension  $x$ . This dimension equals the amount that the stock must be moved for each stroke of the press, and, therefore, the distance that the stop-pin should be located from that edge of the hole which is

to come against the stop-pin. Assuming that the shaded area represents the hole in the blanking die and that point  $y$  on the stock is to engage the stop, then the stop-pin  $s$  should be located a distance  $x$  from this point, in the direction in which the stock is to be fed through the die.

In case the stock is to be passed through the die twice, as indicated at  $B$ , Fig. 41, in order to cut it more economically and without making a multiple die, the openings which are punched successively must be considered when locating the stop-pin or those which occupy the same position relative to the edge of the stock. For instance, if edge  $y$  is to engage the stop-pin, the latter should be located a distance  $x$  equal to the distance from edge  $y$  to the corresponding edge of the next hole which is cut during this same passage of the stock. The position of the stop-pin relative to the hole in the stock, depends upon the shape of the hole. It should be placed so as to engage whatever part of the edge will provide the best contact point for the stop-pin, a straight part of the hole being selected in preference to an irregular section if convenient. Whenever possible, however, the point should be in such a position with relation to the hole that when the stock is pushed against it, the tendency will be to force the stock over towards the guide strip. When punches are equipped with pilots the stop-pin in the die should be so located that when the pilots enter the pierced holes they will tend to move the stock slightly away from the stop-pin. If the stock were crowded against the stop-pin, a sheared die or a burred hole where the pilot enters would be the result.

**Types of Die-beds or Bolsters.** — Dies are usually held in position on the bed of a punch press by means of a die-bed or bolster, although large dies are often attached directly to the press bed.

The subject of die-beds or bolsters is one of considerable importance, and is deserving of greater attention than it often receives in the shop or designing room, because many of the troubles encountered in the use of press tools are due to these parts being badly designed or poorly constructed. Many a fine die has been ruined because it has not been properly secured in



the die-bed and consequently has shifted while in operation; or because the holes in the die-bed through which the blanks or punchings are supposed to pass have not been made large enough to allow them to pass through freely. As a consequence the blanks get jammed in the die-bed and pile up into the die itself and are compressed by the pounding of the punch, until the punch or die breaks from the strain. The principal functions of a die-bed are: first, that of supplying an adequate support for the die, and a holder to hold the die in its proper position to be engaged by the punch; and, second, to furnish a means of attachment to the press. Therefore the principal points to be

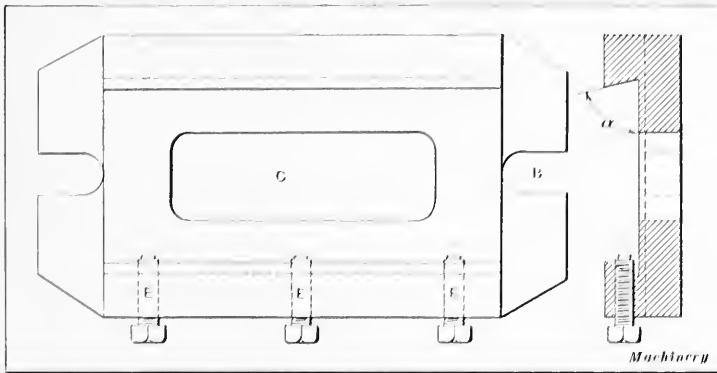

Fig. 42. Form of Die-bed commonly used in Jobbing Shops

considered in the design and construction of a die-bed are first, the method of securing the die, and second, the method of securing the die-bed to the press. Due consideration, of course, should also be given to proportion and strength.

A die-bed of the type generally found in the jobbing shop is shown in Fig. 42. The dovetail method of holding the die, with set-screws *E* to lock it in proper position, is employed. It is fitted with a flange on each end with slots *B* to receive the clamping bolts which pass through the slots into the press bolster. In the center is a rectangular cored hole to let the punchings pass through. This type of die-bed is cheap and convenient for use where several dies are to be used in one die-bed. The dies can be easily slid into place and fastened by means of

the set-screws, and are easily removed when another die is to be used. The angle  $\alpha$  of the dovetail should be from 75 to 80 degrees. This die-bed has the following disadvantages: first, that the die is held into it by set-screws which always have a tendency to jar loose in punch press work, and, second, the cored hole *C*, being necessarily made large to accommodate various shapes of blanks, weakens the die-bed and lessens the support to each of the dies. It is always better, if possible, to have a separate die-bed for each die.

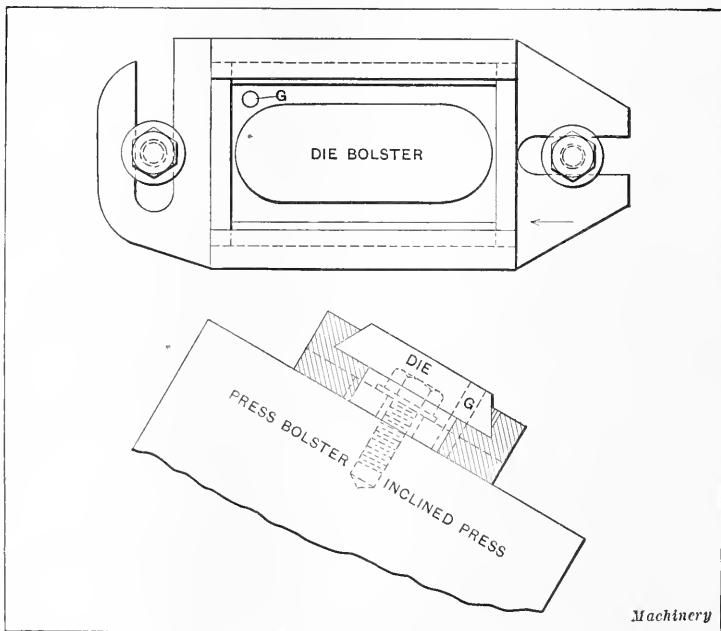

Fig. 43. Die-bed adapted to Inclined Press

In Fig. 43 is shown a die-bed for use on an inclined press. In this bolster the dovetail method of holding the die is used, but without the use of set-screws. The dovetailed opening to receive the die is slightly tapered and the die is driven into place with a copper mallet, and is then made doubly secure by the insertion of a dowel *G* which is driven through the die into the die-bed. The method of clamping this die-bed to the press bolster is different from that shown in Fig. 42, in that the bolt

slot in one flange runs at right angles to that in the opposite flange. By having the slots in this position, the die-bed may be attached or removed without the necessity of taking out the bolts, thus not only saving a great deal of time and trouble in setting the tools, but also preventing the bolt holes from getting filled with scrap or dirt and the bolts from getting lost. This is an excellent die-bed for blanking and piercing work. Another common method of holding a die without the use of set-screws

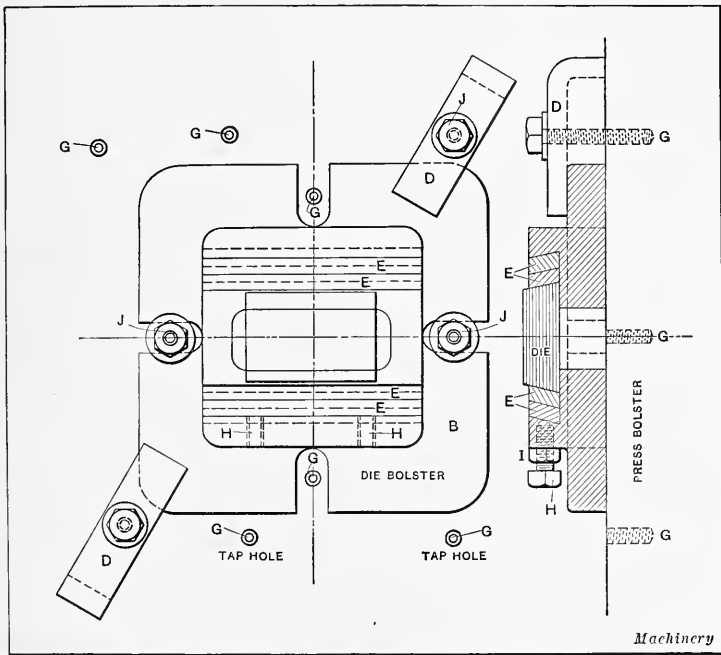

Fig. 44. Form of Die-bed adapted to General Use

is to make the dovetail slot tapering and somewhat wider than the die, so that a taper key can be driven in lengthwise.

An improved type of die-bed for general utility is shown in Fig. 44. In this bed the dovetail method of holding the die is used. In the illustration it will be noticed that there are four parallel pieces or gibs *E* placed along the sides of the die. The object of this construction is to provide for dies of various sizes. When a larger die is to be used one or more of these gibs may be

taken out. This bolster, in addition to four bolt slots, has a flange *B* all around it so that it may be clamped in any position. The set-screws *H* which hold the die in place should be provided with a lock-nut as shown at *I* to lessen the chances of jarring loose. The great advantage of having a flange all around the bolster will be apparent when it becomes necessary to swing the die-bed around enough to bring the bolt slots out of line with the tapped holes in the press bolster. In a case of this kind a die-bed with a flange all around it may be clamped by means of clamps as shown at *D*, using the tapped holes *G* located at different places in the press bolster.

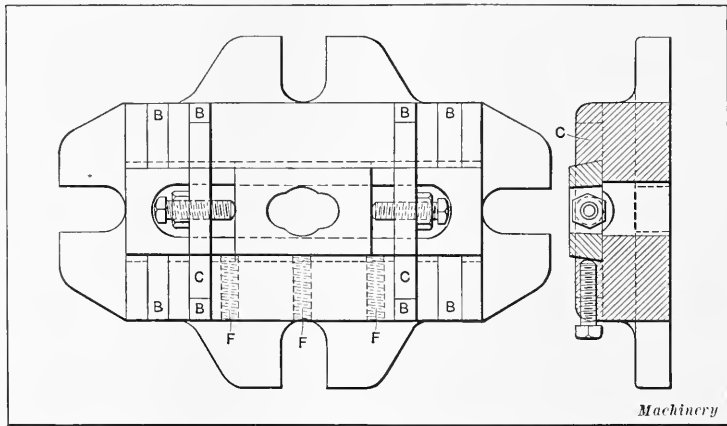

Fig. 45. Die-bed of the Dovetailed Type, equipped with Side Set-screws and End-thrust Screws

In Fig. 45 is shown another die-bed of the dovetail and side set-screw variety, but with the additional feature of end-thrust set-screws. This end-thrust arrangement is a novel feature. In order to obtain this additional means of holding the die securely, two square grooves *B* are cut in each end of the die-bed at right angles to the opening for the die. Into these grooves a plate *C* is fitted in which there is a set-screw in such a position as to come into contact with the end of the die. With one of these plates at each end, and the set-screws screwed tightly against the ends of the die, there is less likelihood of its shifting while in operation. When short dies for simple blanking or piercing are used, the end-thrust plates may be inserted in the inner grooves

as shown in the illustration, whereas if it is desired to use a long die such as is used for progressive work where there is one or more piercing operations before the work reaches the blanking punch, the plates with the set-screws may be placed in the grooves further from the center, and thus allow for the increased length of die. When the set-screws are used in these outer grooves, the heads of the screws will come directly over the slots in the flanges where the clamping bolts should be placed; for this reason the bed should be provided with two extra slotted flanges, as shown in the illustration, to be used when necessary.

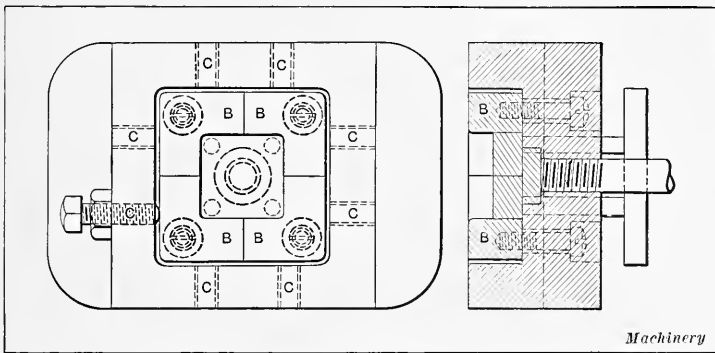

Fig. 46. Die-bed for Sectional or Split Dies

A die-bed for sectional forming or blanking dies or for split dies is shown in Fig. 46. This die-bed is provided with a square receptacle to receive the dies, and with two set-screws on each side to hold the dies in place. The square forming die shown is made in four sections *B* which are held tightly against each other by means of the set-screws *C*, and are held from working up by screws through the bottom of the die-bed — one in each section of the die. A square recess is cast in the die-bed so that when machining the die-bed it is only necessary to plane off the bottom and top of the flanges, mill the bottom of the recess, and drill and tap for the set-screws. The sides of the recess need not be machined as the dies have no bearing on them.

A very simple type of die-bed for bending and forming dies is shown in Fig. 47. It is simply a vise similar in some respects to a milling vise, but having two set-screws to take the place of

the movable jaw. The die is simply set in the bed and clamped against the solid jaw by means of the set-screws. This type of bolster is intended for use only on dies that do not require a "push up," or "knockout," and when the bending or forming operations are done on a solid surface. In order to obtain the best results from this die-bed, the complete outfit of punch-holder, punch, and die of the type shown in the sketch should be used. The punch and die are kept in alignment when in operation by the two guide pins *E* which are secured in the punch and which

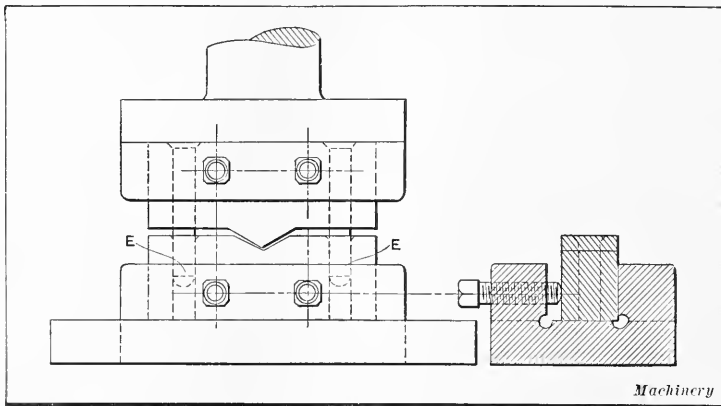

Fig. 47. Simple Form of Die-holder adapted to Bending Dies

enter the die at every stroke of the press, making it practically impossible for the tools to shift while in operation. If it be desired to change the tools it is not necessary to disturb the punch-holder or die-bed. They may be left in the press, and, by simply loosening the set-screws in the die-bed and punch-holder, the punch and die, held together by the guide pins, may be taken out and set aside and another set slipped into their places.

A bolster for combination dies for round drawing work is shown in Fig. 48. This bolster requires but little explanation. It is circular in shape with two steps or extensions, two bolt slots, and a flange all around it to allow it to be clamped at any convenient place. When the combination dies are turned in the lathe, the bottom die is counterbored to be a driving fit on the extension *G*, and is held down by screws that pass through the bed at *E* into the die.

Die-beds are commonly made of cast iron, cast steel, or machined steel. Of late years there has been a tendency among large concerns to have all their die-beds for the power press made from semi-steel castings, or of machine steel for certain classes of heavy work, instead of from cast iron as heretofore. This is done because a cast-iron die-bed that is used day after day for holding dies for cutting heavy metal will not stand up during long and hard usage as it should. Past experience has proved that gray iron die-beds in time become out of square; then, again, they sometimes crack. With the semi-steel, or the

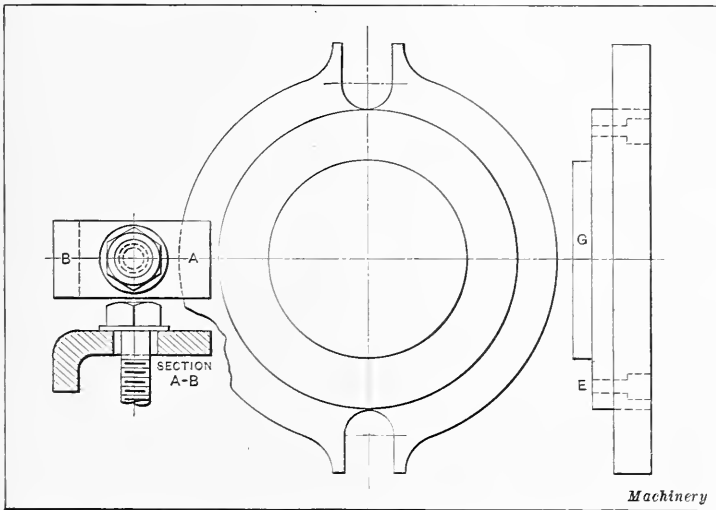

Fig. 48. Die-bed or Bolster for Combination Dies Designed for Round Drawing Operations

soft steel die-bed, this does not happen. It has been found that semi-steel and machine steel die-beds pay for themselves many times over.

**Examples of Blanking and Piercing Dies.** — Some interesting examples of die work taken from the diemaking department of the Taft-Peirce Manufacturing Co. are shown in Fig. 49. While the dies illustrated are used to produce comparatively plain parts, there are some points in their construction which may be of interest and value, particularly to those not experienced in the art of diemaking. The die shown to the left

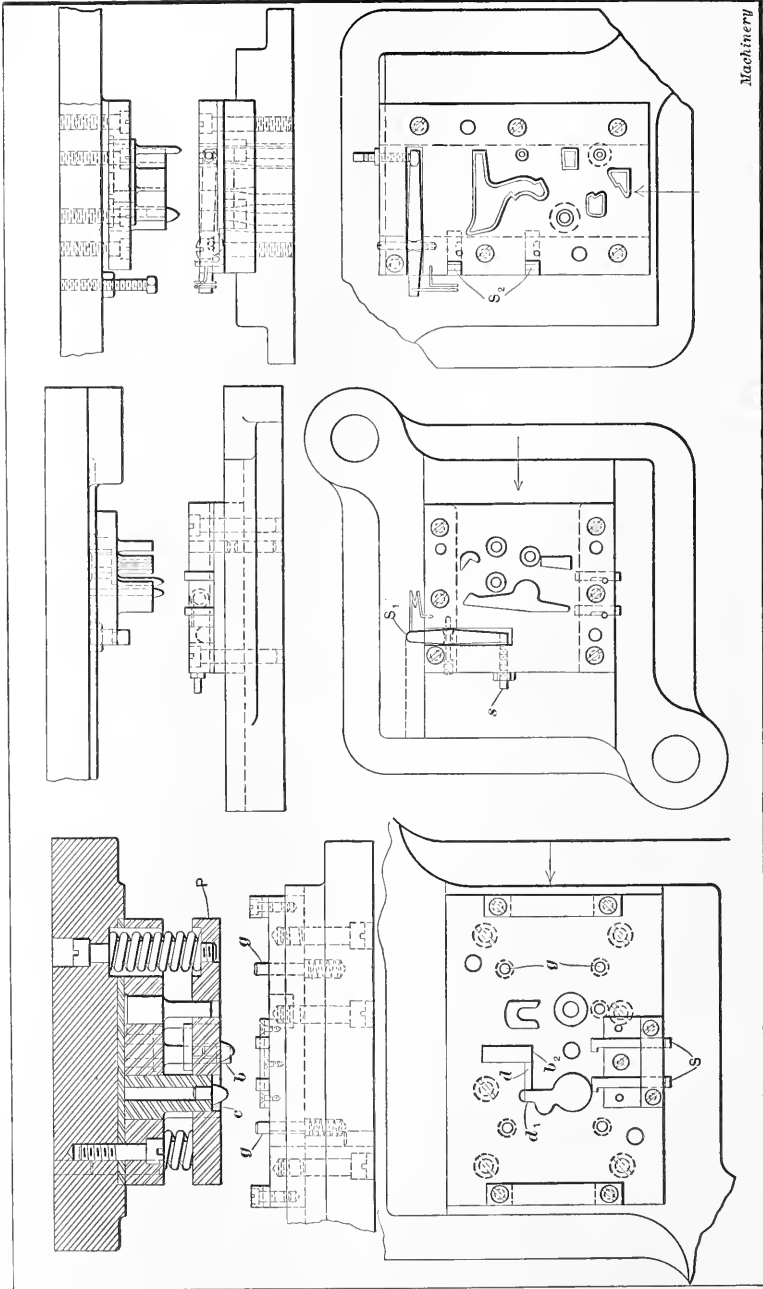

Fig. 49. Punches and Dies for Producing the Parts Illustrated in Fig. 50



is for producing the part illustrated at *A* in Fig. 50, which also shows the successive piercing, bending, and blanking operations. The stock is fed through the die in the direction indicated by the arrow. On the first stroke the piercing operation at *a* is performed by a punch of corresponding shape. On the next stroke a bending punch turns over the part *b*<sub>1</sub>, making a right-angle bend, and, finally, the finished piece is blanked out. Of

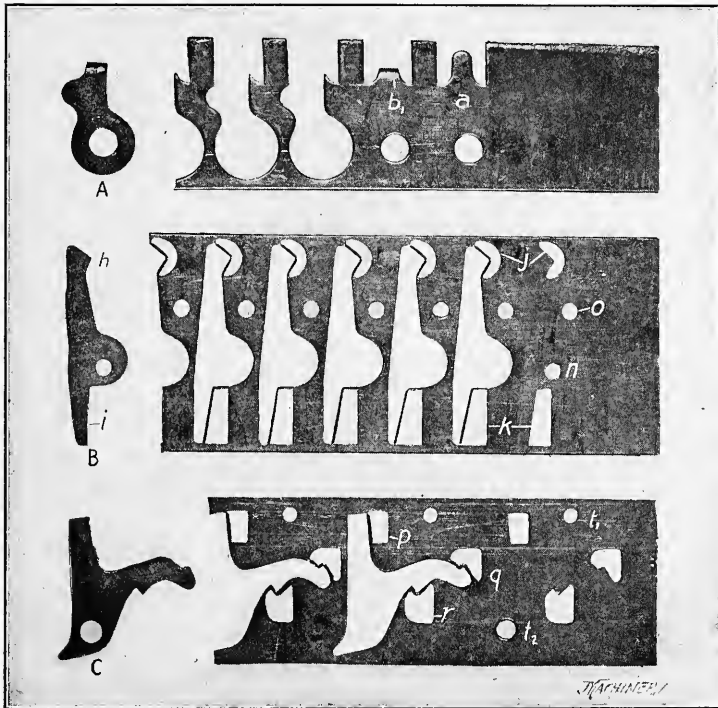

Fig. 50. Blanked Parts and Scrap, Illustrating Successive Operations

course these operations all take place simultaneously, except when the stock is first being started, so that a finished piece is blanked out at each stroke.

One of the interesting features of this die is the method of stopping the stock as it is fed forward. After the bending operation, which takes place at *b*<sub>2</sub> on the die, the bent end *b*<sub>1</sub> (Fig. 50), which projects downward below the surface of the die, is fed forward through channel *d* until it comes against the end *d*<sub>1</sub>

which forms a positive stop. By this simple method, the stock is located for the pilot-pins which accurately position it for the blanking operation. By means of the spring pressure-pad  $P$ , the stock is held firmly against the die, so that it will not be buckled by the bending operation. When the stock is first being started through the die, stops  $S$ , which may be moved in or out as required, are used for locating the stock for the first and second operations.

The die shown in the center of Fig. 49 is for piercing and blanking the pawl illustrated at  $B$  in Fig. 50, which also shows a sample of the scrap. As the V-shaped projection  $h$  on one end of this pawl and the straight surface  $i$  had to have a smooth finish, a shaving operation on these surfaces was required. This operation is not performed in a shaving die after blanking, as would be necessary if the entire contour of the part had to be finished, but it is done in the blanking die by removing a certain amount of metal adjacent to these surfaces, as at  $j$  and  $k$ , during the piercing operation. The result is that when the pawl is blanked, the edges opposite the openings  $j$  and  $k$  are subjected to a shaving action which leaves a smooth surface that is entirely free from the roughness found on the other edges where the stock is sheared from the solid. The narrow shavings, which are removed from the surfaces to be finished, remain attached to the scrap in this particular instance, as the illustration shows. It will be seen that when this method of securing a finished edge is employed, the stock must be accurately located, as the removal of a shaving that is too thick would roughen the edge. In the die illustrated, the stock is located by the two pilot-pins on the punch, one entering the hole  $n$ , Fig. 50, and the other a hole  $o$  pierced simply to give a two-point location, thus insuring accuracy. In practice it has been found that a shaving equal to 10 per cent of the stock thickness is about right for mild steel.

This die is equipped with an automatic stop  $S_1$  which is operated by a projecting screw on the punch in the usual way. The hole in this stop for the pivot on which it swivels is tapered toward the center from both sides, thus giving it a movement

horizontally as well as vertically. With the stop mounted in this way, slight adjustments, to compensate for any error there might be in the location of the stop with reference to the pilots in the punch, can easily be made when the die is being tried out, by simply turning the screw *s* until the stop is properly positioned. The function of the stop is, of course, to locate the stock approximately, and its flexibility prevents the pilots from being subjected to excessive strains. The horizontal adjustment has

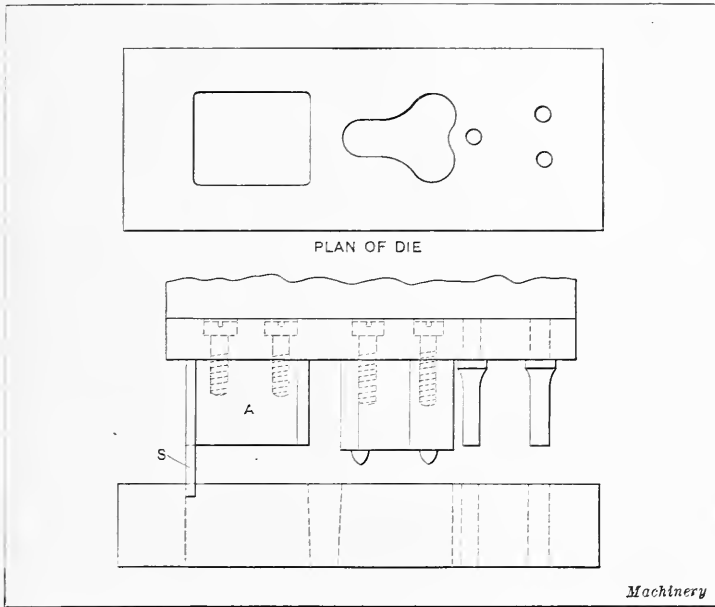

Fig. 51. Follow or Progressive Die equipped with Trimming Punch for Trimming Edge of Sheet Stock

an additional advantage in that the stop does not have to be located so accurately when this adjustment is provided.

Another punch and die of the piercing, shaving, and blanking type is shown to the right in Fig. 49. In this case the work *C* in Fig. 50 had to be finished in three places, as shown by the perforations at *p*, *q*, and *r*. The stock is pierced for shaving by three punches while two other punches pierce the holes  $t_1$  and  $t_2$ , Fig. 50. The hole  $t_1$  is merely for locating purposes, there being two pilots which give a two-point location. This die is also

equipped with an automatic stop similar to the one previously described, and it has small hand stops  $S_2$  which are also common to the designs previously referred to.

**Follow Die Equipped with Trimming Punch.** — When stock is purchased of the proper width for blanking two rows of parts, one edge is placed against the guide of the die and the stock is fed through, after which it is turned over and fed through with the opposite edge against the guide, but if the stock is purchased in sheets, it is necessary to trim the edges every time a row is punched, with the exception of the two outside rows. If no power shears are convenient to the press, this may prove to be a more costly operation than punching, and even though a shear may be located near the press, the operation adds considerably to the cost of the product. To avoid this trouble and expense, a trimming punch  $A$  is sometimes added, as illustrated in Fig. 51, which shows a die of the follow type. The purpose of this punch is to remove the scrap between the openings in the sheet and also to trim the edge of the sheet straight so that it may be used for guiding the stock when blanking out the next row. When a trimming punch is employed, a stop of the type shown at  $S$  in the illustration is used. The end of the scrap strikes this stop, thus locating the stock; when the punch descends, the scrap formed by the blanking operation is cut away, thus trimming the edge straight. When making dies of this class, it is necessary to have the blanking punch longer than the others in order that the locating or pilot-pins on the end can engage the holes in the stock before the other punches begin to cut. It is also advisable to place the stop so that the stock will go a little farther (say, 0.010 inch) than its correct location; then, when the pilot-pins engage the pierced holes they will draw the stock back to the proper position, whereas, if the diemaker attempted to set the stop so as to locate the stock exactly, any dirt or other foreign substance between the end of the scrap and the stop would cause trouble.

## CHAPTER III

### DRAWING AND FORMING DIES

Notwithstanding that drawing dies are extensively used, there has been a lack of definite information pertaining to fundamental principles and rules governing the drawing of sheet metal, which is doubtless due to the fact that the exact method of designing and constructing a drawing die depends, to such a large extent, upon the nature of the drawing operation. Moreover, it is doubtful if any branch of diemaking requires more experience than that which has to do with the drawing of sheet-metal parts. The following information pertaining to drawing die construction and design pertains to practical problems such as are frequently encountered in actual practice.

When a drawing die is to be made for producing a cup or shell, it is necessary to determine what form or type of die will give the best results, what diameter of blank would be required to produce a shell of the required form and depth, and whether more than one drawing operation is necessary. These questions, as well as other important points relating to the drawing of sheet metals, will be considered in this chapter.

**Selecting Type of Drawing Die.** — The type of die to use depends primarily upon the shape of the drawn part and the nature of the drawing operation, although the quantity of parts required may also affect the design of the die. If comparatively shallow cups or shells, such as can or box covers, were required in quantity, a combination die and a single-action press would ordinarily be used, whereas, if the cups were quite deep or simply the first of a series of operations, a double-action blanking and drawing die would usually be employed. On the other hand, if comparatively few drawn parts were needed, it might be advisable to do the work in two operations by first cutting out the blank in a plain blanking die and then drawing it in

another die of the simple push-through type. Such a die, however, should only be used for metal having a thickness of at least  $\frac{1}{16}$  inch and for producing shallow cups.

The principal reason why drawing dies of the combination type having pressure-pads are only adapted to the drawing of shallow cups, is that the pressure of the blank-holder on the stock gradually increases as the cup is drawn, owing to the increased compression of the rubber attachment; consequently, the stress upon the metal being drawn is increased rapidly as the drawing punch descends, because the stress due to the drawing operation is unduly increased by an excessive pressure on the outer part of the blank. When the pressure on the blank is practically uniform, as in the case of a double-action die, a somewhat greater depth can be obtained in one draw, assuming that the same material is used in each case and that other conditions are equal. To avoid this increase of pressure, some combination dies are equipped with a compensating attachment for obtaining a more constant pressure between the drawing punch and blank-holder.

When designing drawing dies the number of drawing operations necessary must also be considered. If a deep shell is to be drawn and a double-action drawing die is used to form the cup, redrawing dies will be necessary to gradually lengthen and reduce the diameter of this cup, in order to form the shell. There are two general types of redrawing dies as already explained in Chapter I. In the simplest type the cup is redrawn by simply being pushed through a smaller die in a single-action press and, if necessary, the shell thus formed is further reduced and elongated by pushing it through a series of similar dies. (The reductions in diameter that are practicable for each draw will be referred to later.) This simple form of redrawing die is used for small parts, especially when the metal is comparatively thick and does not wrinkle, to any great extent, while being drawn. For large thin work, redrawing dies having inside blank-holders are commonly used. The blank-holder prevents the formation of body wrinkles as the work is being pushed through a smaller opening and this support to the body also al-

lows a greater reduction of metal to be obtained in one drawing operation. Redrawing dies having blank-holders should be used when work is large and especially if the stock is thin in proportion to the diameter.

**Depth of the First Drawing Operation.** — When a shell or cup is to be drawn from a flat blank, the diemaker or designer must decide how many drawing operations will be required. Shallow cups, can covers, etc., can be drawn in one operation, but, when a comparatively deep shell is required, two or more operations are necessary, the number depending upon the quality and kind of metal, its thickness, the slant or angle of the dies, the amount that the stock is thinned or ironed in drawing and the thickness of the metal in proportion to the diameter of the work. As a general rule, a plain cylindrical shell should not be drawn to a depth which is greater than its diameter, and some diemakers contend that the depth should not exceed from one-half to two-thirds the diameter. When an attempt is made to draw a blank to a great depth, so much pressure is required to contract the flat stock into a cylindrical shape that the tensile strength of the metal is exceeded. If the shell is to have a flange at the top, it will not be practicable to draw as deeply as previously stated unless the metal is extra good, because the stock is subjected to a higher tensile stress, owing to the larger blank which is necessary for forming the flange.

**Diameter of First Drawing Die.** — When determining the diameter of the first drawing die (often called the “cupping die”), it is well to be conservative and not attempt to draw too deeply in one operation in order to reduce the succeeding operations to a minimum, because broken shells may result. Ordinarily, it is practicable to draw sheet steel of any thickness up to  $\frac{1}{4}$  inch, so that the diameter of the first cup equals about 0.6 of the blank diameter, and under favorable conditions the diameter of the first cup may equal from 0.4 to 0.5 the blank diameter. A good general rule to follow is to make the diameter of the first drawing die equal to the blank diameter divided by 1.8 or,

$$\text{Diameter of die} = \frac{\text{blank diameter}}{1.8}$$

**Diameter Reductions of Drawn Shells.** — When a comparatively deep shell is to be drawn, the cup which is formed from the flat blank in the first drawing die is redrawn one or more times, thus decreasing its diameter and increasing its length. The amount that the diameter of a plain shell can be reduced in these successive steps or redrawing operations, depends upon the quality and kind of metal, its susceptibility to drawing, whether or not the die is equipped with a blank-holder, the thickness of the stock and the amount that the stock is “ironed” or thinned while being drawn. A general idea of the reductions that are practicable for various thicknesses of metal may be obtained from the following figures.

Approximate thickness of sheet steel,					
inch. . . . .	$\frac{1}{16}$	$\frac{1}{8}$	$\frac{3}{16}$	$\frac{1}{4}$	$\frac{5}{16}$
Possible reduction in diameter for each					
succeeding step, per cent. . . . .	20	15	12	10	8

For example, if a shell made of  $\frac{1}{16}$ -inch stock is 3 inches in diameter after the first draw, it can be reduced 20 per cent on the next draw, and so on until the required diameter is obtained. These figures are based upon the assumption that the shell is annealed after the first drawing operation, and at least between every two of the following operations. Necking operations — that is, the drawing out of a short portion of the lower part of the cup into a long neck — may be done without such frequent annealings. In double-action presses, where the inside of the cup is supported by a bushing during drawing, the reductions possible may be increased to 30, 24, 18, 15, and 12 per cent, respectively. (The latter figures may also be used for brass in single-action presses.)

The foregoing figures represent conservative practice and it is often possible to make greater reductions than are indicated by these figures, especially when using a good drawing metal. Taper shells require smaller reductions than cylindrical shells, because the metal tends to wrinkle if the shell to be drawn is much larger than the punch. The amount that the stock is “ironed” or thinned out while being drawn must also be con-



sidered, because a reduction in gage or thickness means greater pressure of the punch against the bottom of the shell; hence the amount that the shell diameter is reduced for each drawing operation must be lessened when much ironing is necessary.

**Formulas for Drawing Die Diameters.** — In order to determine more definitely the diameters that are practicable for drawing dies, several hundred tests were made on various thicknesses of steel stock, using different die and blank diameters. These tests showed that the ratio of  $\frac{\text{die diameter}}{\text{blank diameter}}$  for the same thickness of metal is not constant (assuming that the same quality of drawn work is obtained in each case), but that an increase in blank diameter means an increase in ratio; in other words, the diameter of the first drawing die should be proportionately larger as the diameter of the blank increases. The following formulas for determining die diameters are the result of these tests and apply to drawing dies intended for soft steel or tinplate:

For first-operation dies:

$$d = \frac{X \times D}{100 - 0.635 D}$$

For redrawing dies:

$$d_1 = \frac{X_1 \times d}{100 - 0.635 d}; \quad d_2 = \frac{X_1 \times d_1}{100 - 0.635 d_1}, \text{ etc.}$$

In these formulas,

$D$  = the calculated blank diameter;

$d$  = diameter of the first-operation drawing die;

$d_1$  = diameter for first redrawing die;

$d_2$  = diameter of following redrawing die;

$X$  and  $X_1$  = factors which depend upon the thickness of the metal to be drawn.

These factors  $X$  and  $X_1$  for different thicknesses of stock are given in the accompanying table "Minimum and Maximum Values for Die Diameter Formulas." The numerical values of these factors were found by making several hundred trial draws, using different blank and die diameters and different thicknesses of stock. It should be mentioned that the results

are correct only for dies used in double-action presses where the blank-holder pressure is constant and, in the case of redrawing dies, inside blank-holders having 45-degree drawing edges are employed.

**Minimum and Maximum Values for Die Diameter Formulas**

Metal Thickness, Inch	First-operation Die $X$		All Redrawing Dies $X_1$	
	Minimum	Maximum	Minimum	Maximum
0.016 to 0.018	61	68	74	81
0.02	58	65	73	80
0.022 to 0.024	56	63	72	80
0.028	54	60	71	79
0.03	50	56	70.5	77
0.06	47	53	70	75
0.12		51		65

**Formation of Wrinkles in Drawing.**—The reason why wrinkles tend to form when drawing sheet stock will be more apparent if we consider the action of the metal as it is forced through the die. When a flat blank is drawn either in a combination or double-action die, the outer part is subjected to pressure by the blank-holder; consequently, no wrinkles can form if the die is properly constructed, and all the movement must be radially inward (provided a circular or cylindrical shape is being drawn), but when the metal passes from under the blank-holder and over the edge of the die, it is no longer confined and, as it is being drawn into a smaller circumference, the natural tendency is to wrinkle. These are sometimes known as “body wrinkles” to distinguish them from the “flange wrinkles” which result when there is insufficient pressure between the blank-holder and die.

As the stiffness of sheet metals increases approximately as the square of the thickness, thicker metals also offer more resistance to a buckling or wrinkling action when being reduced to a smaller circumference, than comparatively thin stock. For this reason, stock thicker than  $\frac{1}{16}$  or  $\frac{3}{32}$  inch is often drawn in plain push-through dies that are not provided with a blank-holder, and there is little or no trouble due to wrinkling. When

drawing very thin metal, wrinkles are difficult to avoid, especially if the diameter of the work is quite large. More trouble is experienced from wrinkles on taper than on cylindrical parts. The reason is that when the point of the taper drawing punch engages the stock, there is a comparatively large annular zone of metal between the end of the punch and the edge of the drawing die, and, as the stock is forced into this zone, the natural tendency is to buckle. When drawing tapering cake pans or other parts which have scalloped sides, the wavy formation naturally eliminates trouble from wrinkling; in fact, such parts can be drawn without a blank-holder in a single-action press.

**Drawing Edges for First-operation Dies.** — The shapes of the edges of drawing dies, for cylindrical work, vary somewhat even for dies of the same class. The shape depends, to some extent, upon the nature of the drawing operation, but the different forms of drawing edges in use, even for the same general class of work, are due in part to the difference of opinion among diemakers and also to a lack of specific information on this important point. When first-operation dies and those used for drawing cups from flat blanks are not equipped with a blank-holder, it has been found good practice to bevel the upper part of the die to an angle of 60 degrees, as shown at *A*, Fig. 1. The advantage of this steep beveled surface is that it tends to prevent wrinkling, although a die of this type or one not having a blank-holder should not be used on stock thinner than, say,  $\frac{3}{32}$  or  $\frac{1}{16}$  inch. The amount of bevel for a die of this class should be such that the flat blank will have a bearing *w* of about  $\frac{1}{8}$  inch on each side of the die opening. Some diemakers seldom make this width less than  $\frac{1}{16}$  inch or greater than  $\frac{1}{8}$  inch, whereas, others use a bearing varying from  $\frac{1}{8}$  to  $\frac{3}{16}$  inch, depending upon the size of the die and the thickness of the stock.

The upper and lower edges of the beveled surface are rounded, the radius depending somewhat upon the thickness of the stock. It has been found good practice to vary this radius from about  $\frac{1}{8}$  inch on a die for No. 16 gage stock to about  $\frac{1}{4}$  inch for dies intended for stock of, say,  $\frac{1}{4}$ -inch thickness. The seat or nest for

locating the flat blank concentric with the die opening is formed either by counterboring down into the die or by attaching a locating plate to the top of the die. Some first-operation dies that are not equipped with blank-holders have round edges instead of the bevel form. The latter, however, is considered preferable as it will enable deeper cups to be drawn and there is less tendency of the stock to wrinkle.

Most first-operation drawing dies are equipped with blank-

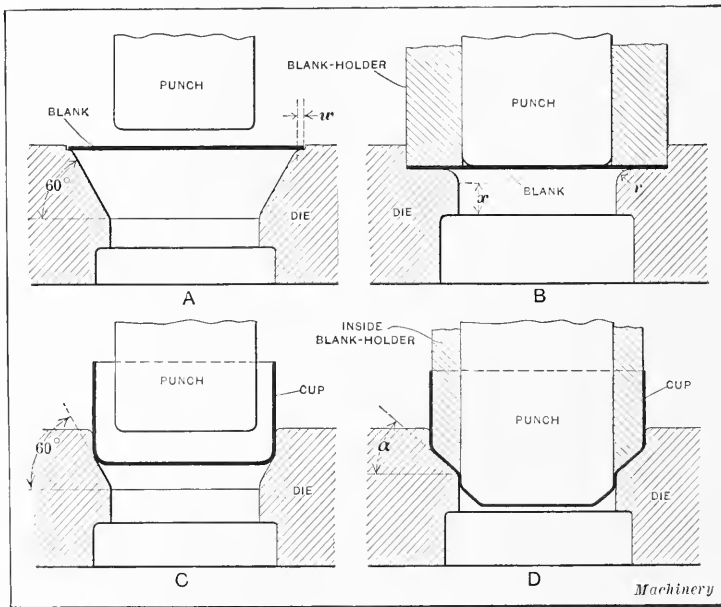

Fig. 1. Shapes of Drawing Surfaces of First-operation Dies and Redrawing Dies

holders and such dies have rounded drawing edges, as indicated at *B*, Fig. 1. When making a die of this form, the radius of the drawing edge is very important. Evidently, if this edge were left square it would tend to cut the metal and the latter would not flow over it readily, if at all; consequently, the stress upon the metal might exceed its tensile strength and the shell would be ruptured. By using a curved drawing surface, however, this difficulty is overcome because the curved edge offers less resistance to the inward flow of the metal. The effective-

ness of a drawing die may depend upon the radius of the drawing edge. For instance, if the radius  $r$  is too large, the flat part of the blank will receive insufficient support from the blank-holder and, as the result, the metal tends to wrinkle after the edge of the blank reaches the curved surface and the metal is no longer supported. If wrinkles form, they may be straightened out by the pressure of the drawing punch, but this operation is liable to develop flaws and minute cracks in the metal unless the latter is very ductile. The radius  $r$  depends upon the thickness of the stock and, to some extent, upon the nature of the drawing operation. A general rule that is used by some diemakers is to give the die a radius equal to from six to ten times the thickness of the stock.

When a part is drawn in one operation, or if the die is for a final operation, and it is especially desirable to secure an even top edge for the cup or shell being drawn, the radius of the drawing edge should be reduced as much as possible. When the outer edge of the blank after leaving the blank-holder begins to pass over the rounded part of the die, it is no longer supported by the blank-holder, and, consequently, is free to follow the natural tendency to wrinkle. Therefore, when it is essential to secure an even top edge, the radius should be reduced to a minimum. If this radius is made too small, however, there is danger of stretching and straining the metal excessively or even tearing it, because of the increased friction resulting from drawing the metal over too sharp an edge. On the other hand, if the radius is too large, the blank lacks the support necessary to prevent wrinkling, as previously mentioned.

For thin stock, this radius may be very small and, in extreme cases, the drawing edge is almost square, the advantage being that thin shallow cups drawn in such a die will have even top edges which, in many cases, do not require trimming. When the stock is thicker than about  $\frac{3}{8}$  inch, the radius can be made fairly large without trouble from wrinkling, because the heavier stock "clings" better to the drawing surface of the die. As a rule, cupping or first-operation dies for drawing cups or shells from flat blanks should always be equipped with blank-holders

for stock thinner than  $\frac{3}{32}$  or  $\frac{1}{16}$  inch, although the diameter reduction that is necessary must, of course, be taken into consideration. The length  $x$  of the drawing surface of the die is usually made about  $\frac{3}{8}$  or  $\frac{1}{2}$  inch. If this surface is too long, it may increase the frictional resistance between the die and shell wall to such an extent that excessive stretching and straining of the metal occurs.

When using a plain push-through type of die, such as is shown at *A*, the relation between the blank and cup diameters is about the same as when using a double-action die. A cup drawn in a push-through die, however, will have a much more uneven edge along the top than if drawn in a die equipped with a blank-holder; consequently, if several redrawing operations were required, it might be necessary to trim the edge of the shell after the third or fourth draw in order to facilitate stripping the shell. It is the practice of the Worcester Pressed Steel Co. not to use plain push-through dies for cups having a depth exceeding  $\frac{1}{2}$  inch, except when the stock is thicker than about  $\frac{3}{8}$  inch. When drawing a comparatively deep cup from stock varying, say, from  $\frac{1}{16}$  to  $\frac{1}{4}$  inch in thickness, without using a blank-holder, the metal tends to thicken or gather in folds toward the top and has to be ironed out, which may cause undue strain on the shell. The minimum stock thickness, when using a plain push-through die, depends somewhat upon the shell diameter.

**Drawing Edges for Redrawing Dies.** — The shapes of the drawing edges for two commonly used types of redrawing dies, or those employed for reducing the diameters of cups or shells, are shown at *C* and *D*, Fig. 1. Sketch *C* shows a die which is similar to the one illustrated at *A* in that it has a 60-degree beveled drawing surface. The upper part of the die, however, has a deeper seat or nest for locating the cup to be redrawn. This simple push-through type of die is used ordinarily for redrawing stock which is at least  $\frac{1}{16}$  inch thick. For thinner metal an inside blank-holder is commonly employed, a die of the type shown at *D* being used. The advantages of this latter type of die for redrawing are that greater diameter reductions can be ob-

tained and there is less tendency for the stock to wrinkle, because the blank-holder supports the metal while it is being drawn from the outer circumference to the smaller one corresponding to the size of the die. As will be seen, the drawing surface is beveled to an angle  $\alpha$  and is joined to the outer seat and inner drawing surface of the die by rounded corners. The radii of these corners is generally made quite small, often being  $\frac{1}{8}$  inch or less. Some diemakers, however, increase the radii of these corners considerably as compared with the figure just given; in fact, in some cases the corners are rounded to such an extent that the straight beveled surface is entirely eliminated and the drawing surface of the die is simply a reverse curve. It is generally conceded, however, that the beveled edge is preferable. In the first place, it is claimed that the metal flows more readily over the beveled edge and there is another advantage in that the beveled surface forms a better seat for the shell, provided the end of the punch in the preceding die is given a corresponding taper.

The angle  $\alpha$  of this beveled seat is generally varied according to the thickness of the metal to be drawn and ranges from 30 to 45 degrees, the thicker the metal the greater the angle. The following data taken from practice, show in a general way, the relation between the angle and stock thickness. For metal thinner than  $\frac{1}{32}$  inch, angle  $\alpha$  is made 30 degrees; for metal varying from  $\frac{1}{32}$  to  $\frac{1}{16}$  inch, angle  $\alpha$  is made 40 degrees, and for stock  $\frac{1}{16}$  inch and thicker, angle  $\alpha$  is made 45 degrees.

**Clearance for First-operation Drawing Die.** — When a flat blank is changed into a cylindrical shape in the drawing die, the natural tendency of the annular part of the blank, which is compressed into a cylindrical shape, is to buckle and wrinkle, because it is changed from a flat to a circular form. Wrinkling is prevented, however, because there is not sufficient room between the die and punch to permit the formation of wrinkles, but the cylindrical wall of a cup which is drawn from a flat blank tends to increase in thickness during the drawing process, because the metal which is confined between the punch and die is compressed or upset circumferentially. Therefore, a first-operation drawing die, or “cupping die,” as it is often called, is sometimes

given a slight clearance to allow for this increase in thickness; that is, instead of making the space between the punch and die equal to the thickness of the stock, the diameter of the die is made equal to the diameter of the punch plus from 2.2 to 2.4 times the stock thickness. For some classes of work additional clearance is allowed to reduce the friction between the stock and the surfaces of the punch and die, the allowance being determined by the following rule: The diameter of the die should equal the diameter of the punch plus from 2.6 to 3.2 times the thickness of the stock.

Insufficient clearance and the resulting increase of friction and wear affect the life of the tools and cause an unnecessary increase in the operating power. On the other hand, if too much clearance is given, the drawn shell will be somewhat conical in shape and full of wrinkles which cannot readily be ironed out by the redrawing dies. It is the practice of some die-makers to allow a slight clearance and then bevel the drawing surface of the die inward towards the bottom to iron out the metal and maintain the original thickness of the stock. If the die is used for a comparatively rough drawing operation, this ironing is not necessary and the stock is allowed to thicken.

**Ironing or Thinning the Stock.** — When a cylindrical shell or similar part is to be drawn and a dead smooth finished surface is required, it is necessary to use stock that is one or two gage numbers heavier than the thickness of the finished shell to allow for the thinning or ironing out of the metal. For instance, if the wall of a shell is to be, say, 0.025 inch thick when drawn, the stock should be of No. 23 (0.0281 inch) or No. 22 (0.0313 inch) U. S. standard gage, so that it can be reduced in thickness while being drawn. Evidently, in order to produce this ironing effect, the space between the punch and die must be somewhat less than the thickness of the stock; that is, the diameter of the punch should be greater than the dimension obtained by subtracting twice the thickness of the stock from the die diameter.

The extent to which shells are ironed or thinned in one drawing operation varies somewhat with the thickness and kind of



metal and also its qualities as to hardness and ductility. When the stock is ironed simply to secure a smooth surface and accuracy as to diameter, about 0.004 inch would ordinarily be allowed for No. 16 gage steel stock. In general, when ironing is required, the diameter of the punch should equal the diameter of the die minus twice the thickness of the stock plus from 0.004 to 0.008 inch. For the final drawing operation, when an extra fine finish is required, the allowances should not be over 0.001 inch on a side; that is, the diameter of the punch should equal the diameter of the die minus twice the thickness of the stock plus 0.002 inch. In many cases, the dies are so made that there is no ironing of the shell until the last drawing operation and then the stock is thinned from 0.001 to 0.003 inch, but this ironing is not done unless necessary. To reduce the thickness of the metal more than the amount specified, the shell should first be drawn to its finished inside diameter and then ironed by separate operations. When thinning the walls of the shell by ironing, it is advisable to run the press slower than for ordinary drawing.

While the foregoing figures apply to ordinary conditions and may not be an accurate guide in every case, they will serve to give a general idea of what is considered good practice. As previously mentioned, when the stock is to be ironed, this must be considered when determining the number of drawing operations, because ironing adds considerably to the pressure of the punch against the bottom of the shell. Therefore, the diameter reduction for each draw must be less when the metal has to be ironed out. It may be necessary to reduce the diameter reductions one-half of what would be practicable when drawing without ironing.

**Finding the Blank Diameter.** — Before making a blanking or drawing die, it is necessary to determine how large the flat blank must be in order to produce a shell or cup of the required form. Until the blank diameter is known, obviously that part of the die which cuts out the blank cannot be made. If the stock did not stretch while being drawn or was not "ironed out" and made thinner, the diameter of the blank could be determined

quite accurately by calculating the area of the finished article and then making the blank the corresponding area. In some cases, there is not much ironing and stretching, as, for example, when the part is drawn or formed to shape in one operation, and then the area method of calculating the blank diameter gives quite accurate results, but if the metal is to be made thinner as it is drawn to shape, the blank should, of course, be proportionately smaller in diameter. The kind of metal to be drawn, that is, whether steel, brass, copper, aluminum, etc., and whether it is hard or soft, also affects the size of the blank to some extent.

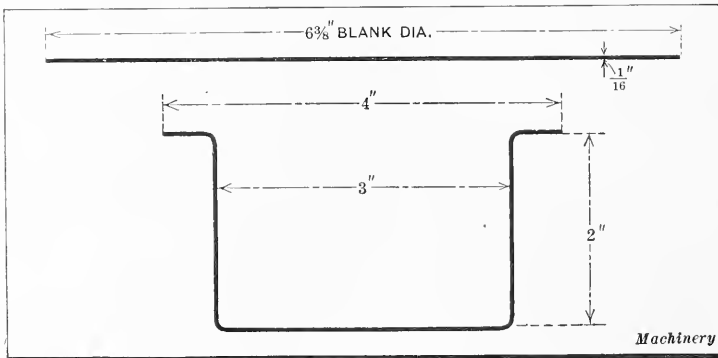

Fig. 2. Flanged Cup and Flat Circular Blank of Corresponding Area

Owing to the uncertainty of obtaining the right blank diameter by calculation, a common method of procedure, especially when constructing drawing dies for parts requiring more than one or two drawing operations, is to make the drawing part of the die first. The actual blank diameter can then be determined by repeated trials, after which the blanking part of the die may be finished. One method is to get a trial blank as near to size as can be estimated. The outline of this blank is then scribed on a flat sheet, after which the blank is drawn. If the finished shell shows that the blank is not of the right diameter, a new trial blank is cut, either larger or smaller than the size indicated by the line previously scribed, this line serving as a guide. If a model or sample shell is available, the blank diameter can also be determined as follows: First cut a blank somewhat large and from the same material used for making the model cup, then

reduce the size of the blank until its weight equals the weight of the model.

**Calculating Blank Diameters.** — A simple method of determining the approximate blank diameter is by calculating the area of the drawn part and then making the blank the corresponding area. To illustrate, suppose the diameter of the blank for the flanged cup shown in Fig. 2 is required. The area of the bottom, which is 3 inches in diameter, equals 7.06 square inches. The area of the side equals  $2 \times 3\frac{1}{8} \times 3.1416 = 19.24$  square inches. The area of the flange equals the area of a 4-inch circle minus the area of a 3-inch circle, or  $12.56 - 7.06 = 5.5$  square inches. The total area equals  $7.06 + 19.24 + 5.5 = 31.80$ . The diameter of a circle having an area of  $31.80 = 6\frac{3}{8}$  inches, nearly. When drawing a trial blank, it is the practice of some diemakers to cut the blanks somewhat smaller than the estimated size and then increase the diameter as may be required. When beginning with blanks that are oversize, the shell is liable to break owing to the excessive stress on the metal. From the foregoing, it will be understood that the blank diameter can only be determined approximately, because some metals stretch more than others and the pressure of the blank-holder as well as the radius or shape of the drawing punch and die, and the amount that the metal is ironed out, all enter into the problem and affect the result. Incidentally, the pressure of the blank-holder should be just enough to prevent formation of wrinkles as the stock is drawn radially inward, and this pressure should be as uniform as possible around all sides.

**Blank Diameter Rule for Plain Shells.** — The blank diameter for a plain cylindrical shell having sharp corners can be determined approximately by the following rule. Multiply the diameter of the finished shell by the height; then multiply the product by 4 and add the result to the square of the finished shell diameter. The square root of the sum thus obtained equals the blank diameter.

**Formulas for Blank Diameters.** — The diameters of blanks for plain cylindrical shells can be calculated by the following formula which corresponds to the rule given in the preceding

paragraph. This formula gives a close approximation for thin stock and is one that has been extensively used:

$$D = \sqrt{d^2 + 4dh} \quad (1)$$

in which  $D$  = diameter of flat blank;  $d$  = diameter of finished shell;  $h$  = height of finished shell. The blank diameters given in the accompanying table are based on this formula and are for sharp-cornered shells. The application of the formula is illustrated by the following example:

If the diameter of a finished shell is to be 1.5 inch, and the height, 2 inches, the trial diameter of the blank would be found as follows:

$$D = \sqrt{1.5^2 + 4 \times 1.5 \times 2} = \sqrt{14.25} = 3.78 \text{ inches.}$$

For a round-cornered cup, the following formula, in which  $r$  equals the radius of the corner, will give fairly accurate diameters, provided the radius does not exceed, say,  $\frac{1}{4}$  the height of the shell:

$$D = \sqrt{d^2 + 4dh} - r. \quad (2)$$

These formulas are based on the assumption that the thickness of the drawn shell is the same as the original thickness of the stock, and that the blank is so proportioned that its area will equal the area of the drawn shell. This method of calculating the blank diameter is quite accurate for thin material, when there is only a slight reduction in the thickness of the metal incident to drawing; but when heavy stock is drawn and the thickness of the finished shell is much less than the original thickness of the stock, the blank diameter obtained from Formulas (1) and (2) will be too large, because when the stock is drawn thinner, there is an increase in area. When an appreciable reduction in thickness is to be made, the blank diameter can be obtained by first determining the "mean height" of the drawn shell by the following formula. This formula is only approximately correct, but will give results sufficiently accurate for most work:

$$M = \frac{ht}{T} \quad (3)$$

Approximate Diameters of Blanks for Cylindrical Shells

Diameter	Height of Shells																							
	¼	½	¾	1	1¼	1½	1¾	2	2¼	2½	2¾	3	3¼	3½	3¾	4	4¼	4½	4¾	5	5¼	5½	5¾	6
¼	0.56	0.75	0.90	1.03	1.14	1.25	1.35	1.44	1.52	1.60	1.68	1.75	1.82	1.89	1.95	2.01	2.08	2.14	2.19	2.25	2.30	2.36	2.41	2.46
½	0.87	1.12	1.32	1.50	1.66	1.80	1.94	2.06	2.18	2.29	2.40	2.50	2.60	2.69	2.78	2.87	2.96	3.04	3.12	3.21	3.29	3.36	3.44	3.50
¾	1.14	1.44	1.68	1.89	2.08	2.25	2.41	2.56	2.70	2.84	2.97	3.09	3.21	3.33	3.44	3.54	3.65	3.75	3.85	3.95	4.04	4.13	4.22	4.31
1	1.41	1.73	2.00	2.24	2.45	2.65	2.83	3.00	3.16	3.32	3.46	3.61	3.74	3.87	4.00	4.12	4.24	4.36	4.47	4.58	4.69	4.80	4.90	5.00
1¼	1.68	2.01	2.30	2.56	2.79	3.01	3.21	3.40	3.58	3.75	3.91	4.07	4.22	4.37	4.51	4.64	4.77	4.91	5.03	5.15	5.27	5.39	5.50	5.62
1½	1.94	2.29	2.60	2.87	3.12	3.36	3.57	3.78	3.97	4.15	4.33	4.50	4.66	4.82	4.98	5.12	5.27	5.41	5.55	5.68	5.81	5.94	6.06	6.18
1¾	2.19	2.56	2.88	3.17	3.44	3.68	3.91	4.13	4.34	4.53	4.72	4.91	5.08	5.26	5.41	5.58	5.73	5.88	6.03	6.17	6.31	6.45	6.58	6.71
2	2.45	2.83	3.16	3.46	3.74	4.00	4.24	4.47	4.69	4.90	5.10	5.29	5.48	5.66	5.83	6.00	6.16	6.32	6.48	6.63	6.78	6.93	7.07	7.21
2¼	2.70	3.09	3.44	3.75	4.04	4.31	4.56	4.80	5.03	5.25	5.46	5.66	5.86	6.05	6.23	6.41	6.58	6.75	6.91	7.07	7.23	7.39	7.54	7.69
2½	2.96	3.36	3.71	4.03	4.33	4.61	4.87	5.12	5.36	5.59	5.81	6.02	6.22	6.42	6.61	6.80	6.98	7.16	7.33	7.50	7.66	7.82	7.98	8.14
2¾	3.21	3.61	3.98	4.31	4.62	4.91	5.18	5.44	5.68	5.92	6.15	6.37	6.58	6.79	6.99	7.18	7.37	7.55	7.73	7.91	8.08	8.25	8.41	8.58
3	3.46	3.87	4.24	4.58	4.90	5.20	5.48	5.74	6.00	6.25	6.48	6.71	6.93	7.14	7.35	7.55	7.75	7.94	8.12	8.31	8.49	8.66	8.83	9.00
3¼	3.71	4.13	4.51	4.85	5.18	5.48	5.77	6.04	6.31	6.56	6.80	7.04	7.27	7.49	7.70	7.91	8.11	8.31	8.50	8.69	8.88	9.06	9.24	9.41
3½	3.97	4.39	4.77	5.12	5.45	5.77	6.06	6.34	6.61	6.87	7.12	7.36	7.60	7.83	8.05	8.26	8.47	8.67	8.87	9.07	9.26	9.45	9.63	9.81
3¾	4.22	4.64	5.03	5.39	5.73	6.05	6.35	6.64	6.91	7.18	7.44	7.69	7.92	8.16	8.38	8.61	8.82	9.03	9.24	9.44	9.63	9.83	10.02	10.20
4	4.47	4.90	5.29	5.66	6.00	6.32	6.63	6.93	7.21	7.48	7.75	8.00	8.25	8.49	8.72	8.94	9.17	9.38	9.59	9.80	10.00	10.20	10.39	10.58
4¼	4.72	5.15	5.55	5.92	6.27	6.60	6.91	7.22	7.50	7.78	8.05	8.31	8.56	8.81	9.04	9.28	9.50	9.72	9.94	10.15	10.36	10.56	10.76	10.96
4½	4.98	5.41	5.81	6.19	6.54	6.87	7.19	7.50	7.78	8.08	8.35	8.62	8.87	9.12	9.37	9.60	9.84	10.06	10.28	10.50	10.71	10.92	11.12	11.32
4¾	5.22	5.66	6.07	6.45	6.80	7.15	7.47	7.78	8.08	8.37	8.65	8.92	9.18	9.44	9.69	9.93	10.16	10.40	10.62	10.84	11.06	11.27	11.48	11.69
5	5.48	5.92	6.32	6.71	7.07	7.42	7.75	8.06	8.37	8.66	8.94	9.22	9.49	9.75	10.00	10.25	10.49	10.72	10.95	11.18	11.40	11.62	11.83	12.04
5¼	5.73	6.17	6.58	6.97	7.33	7.68	8.02	8.34	8.65	8.95	9.24	9.52	9.79	10.05	10.31	10.56	10.81	11.05	11.28	11.51	11.74	11.96	12.18	12.39
5½	5.98	6.42	6.84	7.23	7.60	7.95	8.29	8.62	8.93	9.23	9.53	9.81	10.08	10.36	10.62	10.87	11.12	11.37	11.61	11.84	12.07	12.30	12.52	12.74
5¾	6.23	6.68	7.09	7.49	7.86	8.22	8.56	8.89	9.21	9.52	9.83	10.10	10.38	10.66	10.92	11.18	11.44	11.69	11.93	12.17	12.40	12.63	12.85	13.08
6	6.48	6.93	7.35	7.75	8.12	8.49	8.83	9.17	9.49	9.80	10.10	10.39	10.68	10.95	11.23	11.49	11.75	12.00	12.25	12.49	12.73	12.96	13.19	13.42

in which  $M$  = approximate mean height of drawn shell;  $h$  = height of drawn shell;  $t$  = thickness of shell;  $T$  = thickness of metal before drawing. After determining the mean height, the blank diameter for the required shell diameter is obtained from the table previously referred to, the mean height being used instead of the actual height.

*Example.* — Suppose a shell 2 inches in diameter and  $3\frac{3}{4}$  inches high is to be drawn, and that the original thickness of the stock is 0.050 inch, and thickness of drawn shell, 0.040 inch. To what diameter should the blank be cut? Using Formula (3) to obtain the mean height:

$$M = \frac{ht}{T} = \frac{3.75 \times 0.040}{0.050} = 3 \text{ inches.}$$

According to the table, the blank diameter for a shell 2 inches in diameter and 3 inches high is 5.29 inches, the mean height being used when referring to the table, as previously mentioned. This formula is accurate enough for all practical purposes, unless the reduction in the thickness of the metal is greater than about one-fifth the original thickness. When there is considerable reduction, a blank calculated by this formula produces a shell that is too long. This, however, is an error in the right direction, as the edges of drawn shells are ordinarily trimmed. If the shell has a rounded corner, the radius of the corner should be deducted from the figures given in the table. For example, if the shell referred to in the foregoing example had a corner of  $\frac{1}{4}$ -inch radius, the blank diameter would equal  $5.29 - 0.25 = 5.04$  inches.

Another formula which is sometimes used for obtaining blank diameters for shells, when there is a reduction in the thickness of the stock, is as follows:



$$D = \sqrt{a^2 + (a^2 - b^2)\frac{h}{t}} \quad (4)$$

In this formula  $D$  = blank diameter;  $a$  = outside diameter;  $b$  = inside diameter;  $t$  = thickness of shell at bottom;  $h$  = depth of shell. This formula is based on the cubic contents of

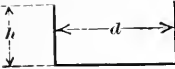
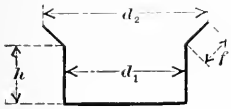
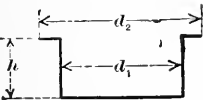
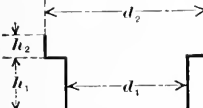
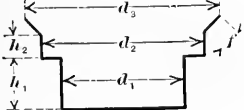
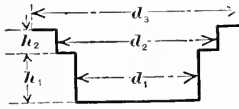
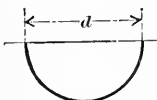
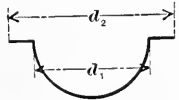
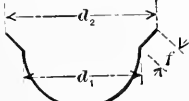
Blank Diameter Formulas for Drawn Shells — I

Shape of Body	Diameter of Blank $D =$
	$\sqrt{d^2 + 4 dh}$
	$\sqrt{d_1^2 + 4 d_1 h + 2 f (d_1 + d_2)}$
	$\sqrt{d_2^2 + 4 d_1 h}$
	$\sqrt{d_2^2 + 4 (d_1 h_1 + d_2 h_2)}$
	$\sqrt{d_2^2 + 4 (d_1 h_1 + d_2 h_2) + 2 f (d_2 + d_3)}$
	$\sqrt{d_3^2 + 4 (d_1 h_1 + d_2 h_2)}$
	$\sqrt{2 d^2} = 1.414 d$
	$\sqrt{d_1^2 + d_2^2}$
	$1.414 \sqrt{d_1^2 + f (d_2 + d_1)}$

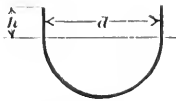
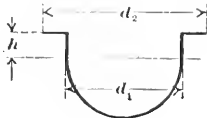
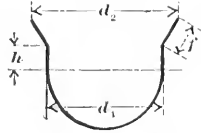
## Blank Diameter Formulas for Drawn Shells — 2

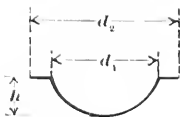
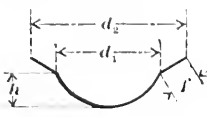
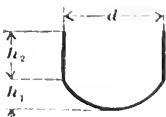
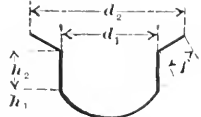
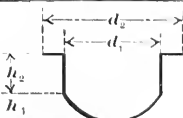
Shape of Body	Diameter of Blank $D =$
	$1.414 \sqrt{d^2 + 2dh}$
	$\sqrt{d_1^2 + d_2^2 + 4d_1h}$
	$1.414 \sqrt{d_1^2 + 2d_1h + f(d_1 + d_2)}$
	$\sqrt{d^2 + 4h^2}$
	$\sqrt{d_2^2 + 4h^2}$
	$\sqrt{d_1^2 + 4h^2 + 2f(d_1 + d_2)}$
	$\sqrt{d^2 + 4(h_1^2 + dh_2)}$
	$\sqrt{d_1^2 + 4 \left[ h_1^2 + d_1h_2 + \frac{f}{2}(d_1 + d_2) \right]}$
	$\sqrt{d_2^2 + 4(h_1^2 + d_1h_2)}$

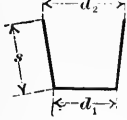
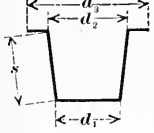
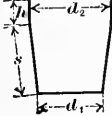
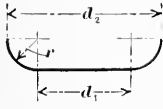
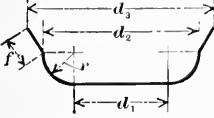
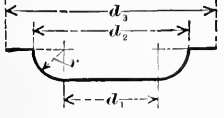
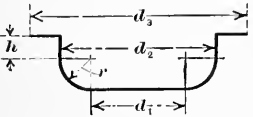
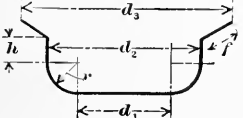

Blank Diameter Formulas for Drawn Shells — 3

Shape of Body	Diameter of Blank $D =$
	$\sqrt{d_1^2 + 2s(d_1 + d_2)}$
	$\sqrt{d_1^2 + 2s(d_1 + d_2) + d_3^2 - d_2^2}$
	$\sqrt{d_1^2 + 2[s(d_1 + d_2) + 2d_2h]}$
	$\sqrt{d_1^2 + 6.28rd_1 + 8r^2}; \text{ or}$ $\sqrt{d_2^2 + 2.28rd_2 - 0.56r^2}$
	$\sqrt{d_1^2 + 6.28rd_1 + 8r^2 + 2f(d_2 + d_3)}; \text{ or}$ $\sqrt{d_2^2 + 2.28rd_2 + 2f(d_2 + d_3) - 0.56r^2}$
	$\sqrt{d_1^2 + 6.28rd_1 + 8r^2 + d_3^2 - d_2^2}; \text{ or}$ $\sqrt{d_3^2 + 2.28rd_2 - 0.56r^2}$
	$\sqrt{d_1^2 + 6.28rd_1 + 8r^2 + 4d_2h + d_3^2 - d_2^2}; \text{ or}$ $\sqrt{d_3^2 + 4d_2(0.57r + h) - 0.56r^2}$
	$\sqrt{d_1^2 + 6.28rd_1 + 8r^2 + 4d_2h + 2f(d_2 + d_3)}; \text{ or}$ $\sqrt{d_2^2 + 4d_2\left(0.57r + h + \frac{f}{2}\right) + 2d_3f - 0.56r^2}$

the drawn shell. It is assumed that the shells are cylindrical, and no allowance is made for a rounded corner at the bottom, or for trimming the shell after drawing. To allow for trimming, add the required amount to depth  $h$ . When a shell is of irregular cross-section, if its weight is known, the blank diameter can be determined by the following formula:

$$D = 1.1284 \sqrt{\frac{W}{wt}} \quad (5)$$

in which  $D$  = blank diameter in inches;  $W$  = weight of shell;  $w$  = weight of metal per cubic inch;  $t$  = thickness of the shell.

The tables "Blank Diameter Formulas for Drawn Shells," contain the formulas for many common shapes.

These formulas are based upon the long-established rule that the area of the blank equals approximately the area of the shell. It is also assumed that the metal, which is comparatively thin, does not undergo any great change of thickness while the flat blank is converted into a shell. All corners at the bottom are shown sharp, which is a condition that is practically impossible to obtain in drawing dies, as the metal will not stand the strain. The radius of these corners should not be less than six to ten times the metal thickness for tin plate and four to five times for copper plate, according to the quality. Otherwise, the table is self-explanatory and no further comment is necessary.

**Formation of Air Pockets in Dies.** — When making drawing and forming dies, it is important to provide vent holes wherever the air would be compressed excessively in the operation of the die, if such vents do not exist. Dies have often given trouble and even proved to be complete failures because of the formation of air pockets. Vent holes are needed, in some cases, to prevent the air from being entrapped between the work and the punch or die, and in other cases to facilitate removing or stripping a close-fitting cup or shell from a punch. For instance, if an air pocket is formed between the end of the cup and a forming punch, the air compression may be high enough to burst the end of the cup. The remedy is to drill a vent hole into the air pocket so that the air can escape. Drawing punches

are often provided with small vent holes which extend from the end of the punch to some point beyond the top of the drawn shell. This vent allows the air to enter the space between the end of the punch and the bottom of the shell when the latter is being stripped, thus preventing the formation of a partial vacuum which would interfere with the removal of the work. The pressure pads, or blank holders, on dies of the combination type sometimes cause trouble by compressing the air as they descend during the drawing operation. This compression is, of course, more pronounced when the supporting pins which connect with the rubber pressure attachment are closely fitted to the holes in the base of the die. Air vents are sometimes formed for the space beneath the pressure pad, by simply cutting small slots or grooves along the supporting pins, thus providing outlets for the air as the pressure pad descends during the drawing operation. Much depends upon the location of the vent holes. For instance, sometimes when a vent is required at the end of the forming punch, it should be placed at one side rather than in the center of the punch, because the air is entrapped at the outer corner of the cup as the latter is pressed to its final shape. Before drilling vent holes, the action of the die should be carefully studied. The effect which a vent hole might have upon the strength of a punch or die should also be considered. When the parts of the die have not been closely fitted together (perhaps because accuracy was unnecessary) vent holes may not be needed.

**Lubricants for Drawing and Forming.** For drawing steel, the following mixture is recommended as a lubricant: 25 per cent flaked graphite; 25 per cent beef tallow, and 50 per cent lard oil. This mixture should be heated and the work dipped into it. Oildag mixed with heavy grease is also used for steel, and a thin mixture of grease (preferably tallow) and white lead has proved satisfactory. The following compound is also used for drawing sheet steel of a mild grade: Mix one pound of white lead, one quart of fish oil, three ounces of black lead, and one pint of water. These ingredients should be boiled until thoroughly mixed. A mixture of white lead and kerosene is also

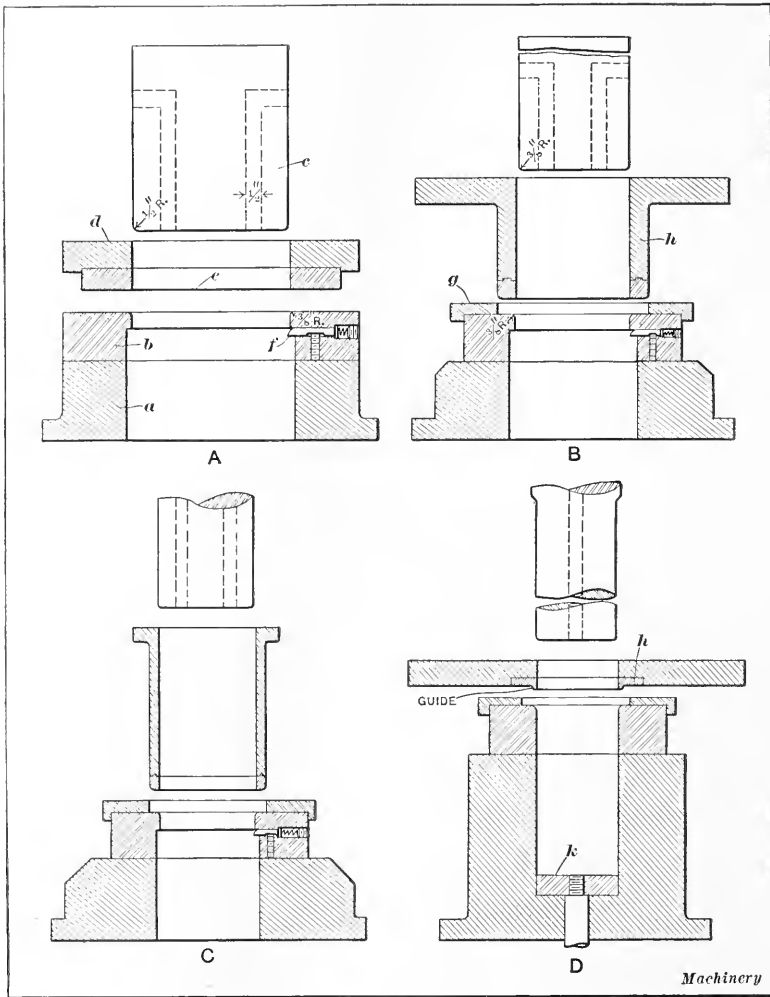

Fig. 3. Drawing Dies for the Successive Operations Illustrated in Fig. 4

recommended for steel, especially for heavy drawing operations. For working brass or copper, a solution composed of 15 pounds of Fuller's soap to a barrel of hot water (used hot), or any soap strong in rosin or potash, is cheaper and cleaner than oil. The stock should pass through a tank filled with this solution before entering the dies. For drawing aluminum, vaseline of a cheap grade is sometimes used. Lard oil is also applied to aluminum

when drawing deep shells. Kerosene is used for drawing aluminum and is said to prevent the dies from becoming "loaded" as the result of the abrasive action of the metal. For comparatively deep drawing, a lubricant having more "body" should be used. Incidentally, kerosene is also used when cutting aluminum in blanking dies. Aluminum should never be worked without a lubricant. Zinc may be lubricated with kerosene, and it is sometimes warmed as well as lubricated, to facilitate drawing. For many classes of die work, no lubricant

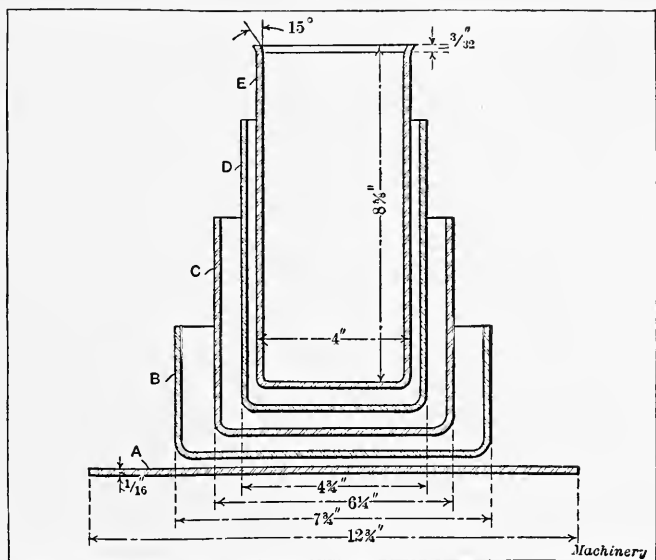

Fig. 4. The Blank and Successive Drawing Operations for Producing Steel Shell E

is required, especially when the metal is of a "greasy" nature, like tin plate, for instance.

**Annealing Drawn Shells.** — When drawing steel, iron, brass, or copper, annealing is necessary after two or three draws have been made, as the metal is hardened by the drawing process. For steel and brass, anneal between every other reduction, at least. Tin plate or stock that cannot be annealed without spoiling the finish must ordinarily be drawn to size in one or two operations. Aluminum can be drawn deeper and with less

annealing than the other commercial metals, provided the proper grade is used. In case it is necessary to anneal aluminum, this can be done by heating it in a muffle furnace, care being taken to see that the temperature does not exceed 700 degrees F.

**Dies for Drawing a Cylindrical Shell.** — A set of drawing dies for producing a cylindrical steel shell, 4 inches in diameter and  $8\frac{5}{8}$  inches long, is shown in Fig. 3. The successive operations are illustrated in Fig. 4. The flat circular blank from which the shell is drawn is made of sheet steel,  $\frac{1}{16}$  inch thick and  $12\frac{3}{4}$  inches in diameter. This flat blank is first drawn into the form of a shallow cup *B* which is reduced in diameter and lengthened to the required size by operations *C*, *D*, and *E*, as Fig. 4 indicates. The first drawing or cupping die is illustrated at *A*, Fig. 3. The die-bed *a* is made of cast iron and the drawing die *b*, of machine steel, pack-hardened. The punch *c* is also made of machine steel and pack-hardened, whereas the blank-holder *d* is of cast iron faced with a hardened machine steel ring *e*. The cup is stripped from the punch by means of a finger *f* which is backed by a spiral spring and engages the top of the drawn part when the punch ascends, thus stripping it off. Many dies do not have these stripping fingers, the work being removed from the punch, when the latter ascends, by contact with the lower edge of the die. The use of stripping fingers, however, gives a more positive action and they are particularly desirable for deep drawing operations.

The construction of the die for the second operation (see view *B*, Fig. 3) is practically the same as the one just referred to, except that it is provided with a gage plate *g* for centering the cup with the die. An inside blank-holder *h* is also used for steadying the cup while it is being redrawn. The size of the shell produced in this die is indicated at *C*, Fig. 4. After these two drawing operations the shell is annealed and is then put through die *C*. As will be seen, this die is also equipped with an inside blank-holder and a gage plate for centering the shell to be redrawn. The cup, *D*, Fig. 4, after the third drawing operation, was too long to be inserted in the press available for the fourth drawing operation, and had to be trimmed to a length of  $7\frac{1}{2}$

inches. It was then redrawn in die *D*. The shell is kept in an upright position in the die by guide *h*, which fits in the top of the shell and holds it while the punch descends. The distance between the bed and ram of the press was not sufficient to allow the use of this guide without trimming the shell; this operation, however, could have been dispensed with if a suitable press had been available. Prior to the final drawing operation, the shell was annealed and after being drawn was trimmed to the required length. This last drawing die is provided with a knock-out *k*, which is necessary because it is impossible to force the

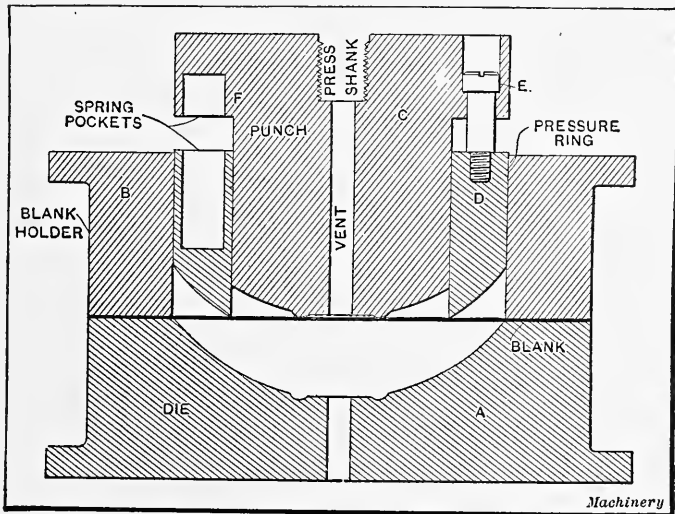

Fig. 5. Triple-action Die for Drawing Spherical-shaped Covers

shell through the die in this operation on account of a small 15-degree flange which had to be formed around the top edge, as indicated in Fig. 4. All of the drawing punches are provided with air passages to facilitate stripping the work.

**Drawing Spherical Covers.**—A punch and die for drawing spherical covers to the full depth in one operation without leaving a wrinkle, and finishing four at a time, are shown in Figs. 5, 6, and 7. The shape of the drawn part is indicated by the heavy line in Fig. 7. As is well known, it is difficult to draw a shell to this shape in one operation by the use of a standard double-

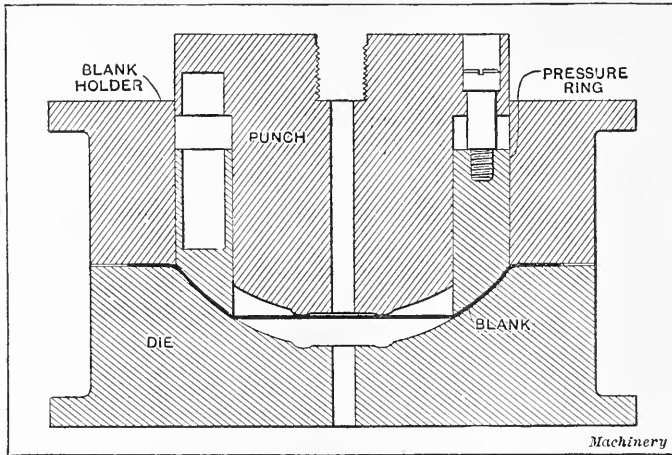

Fig. 6. View Showing First Stage of Spherical Cover Drawing Operation

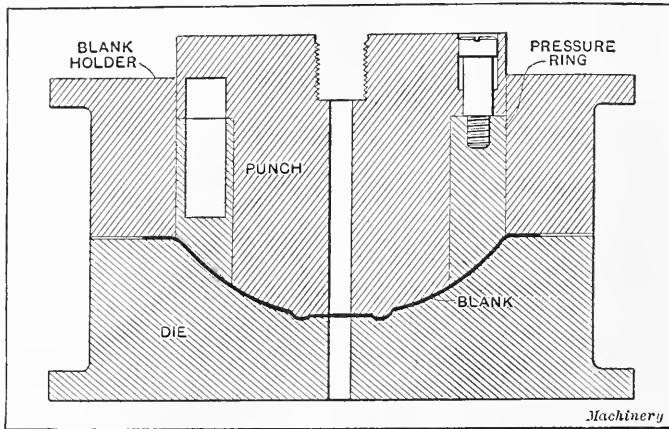

Fig. 7. Relative Positions of Punch, Die and Pressure Ring when Spherical Covers are Drawn

action die, because the stock tends to wrinkle and tear, making it necessary to remove the wrinkles by another operation. To enable this work to be done in one operation a triple-acting die for use in a double-acting press was designed. Fig. 5 shows the relative positions of the punch, pressure ring, and blank-holder, just before the drawing operation begins. The action is as follows: After the four blanks have been placed in position on the top face of die *A*, blank-holder *B* descends until it holds the



blanks firmly against the die face. The pressure ring *D* (which is backed up by heavy springs that are strong enough to form the first drawing operation) then descends to the position indicated in Fig. 6. This pressure ring then acts as an inner blank-holder while the punch descends to the bottom of the die, thus forming the central part of the blank, as indicated in Fig. 7. The action of this die was perfect and no defective shells were produced, the drawing being easy and uniform.

The die is made of cast iron and provided with a vent hole,

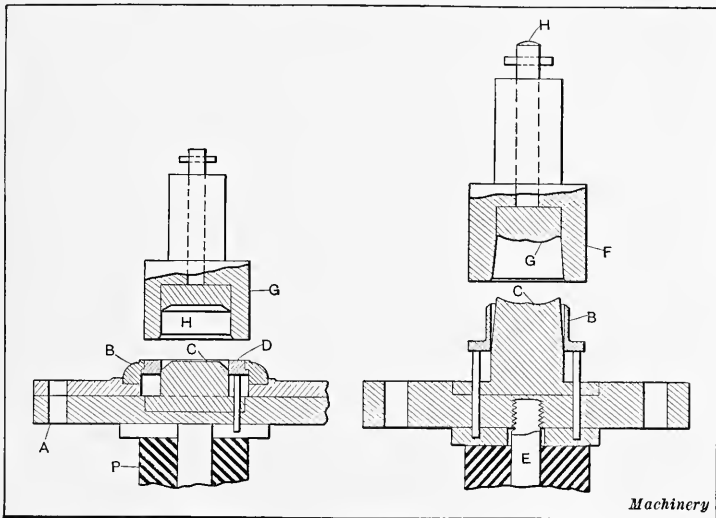

Fig. 8. First-operation Die for Can Nozzles

Fig. 9. Redrawing Die for Can Nozzles

as shown, through which the ejector operates. The drawing faces of both the die and blank-holder conform to the size of the blank. The blank-holder is of the regulation double-action type and is made of cast iron. Both the die and blank-holder are secured to the press by means of a clamping flange. The pressure ring is held in position by several screws *E* between which are the pockets which contain the heavy spiral springs. These covers are of a large size, ranging from 15 to 22 inches in diameter.

**Drawing Dies for Making Tin Nozzles.** — Dies for the production of nozzles for tin cans of large sizes are illustrated in

Figs. 8 to 11 inclusive. These dies, with the exception of the one for the finishing operation, are of the combination type and, therefore, used in single-action presses. The die for the first operation is shown in Fig. 8 and is composed of the following principal parts: A bolster plate *A*; a blanking die *B*; a drawing punch *C*; and a pressure ring or blank-holder *D*, which rests upon three pins connecting with the rubber pressure attach-

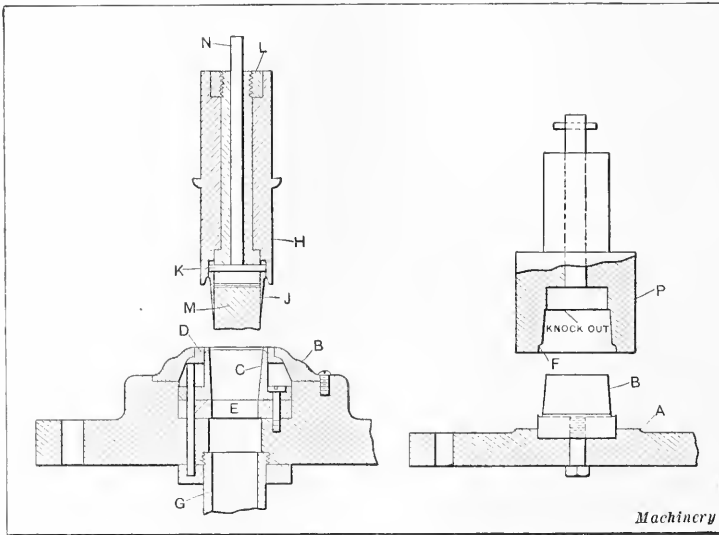

Fig. 10. Die for Third Operation on Can Nozzles

Fig. 11. Die for Finishing Can Nozzles

ment *P* for regulating the pressure while drawing the shell. The combined blanking punch and drawing die *G* is fitted on the outside to blanking die *B*, whereas, the inside diameter equals the diameter of the drawing punch *C* plus twice the thickness of the stock. The forming pad *H* within the punch is made to fit the top of the drawing punch for forming the top of the shell at the end of the stroke. As will be seen, this part also serves as a knockout for the drawn shells. This die is operated by a press of the inclinable type. The punch, as it comes into contact with the blanking die *B*, cuts the blank which is then held by pressure ring *D* against the end of punch *G*; as the punch descends, the blank is drawn over the drawing punch

*C* and when it moves upward the stem of the knockout comes into contact with a bar in the press, thus pushing the pad *H* down and forcing the shell out. The form produced in this die is illustrated at *A*, in Fig. 12.

The die for the second operation is shown in Fig. 9. The center block or drawing punch *C* of this die is tapered, and the punch *F* is also bored out to a corresponding taper. The pad *G* in the punch is of a peculiar shape, as will be noticed; the reason for this shape will be explained later. The shell is placed on the drawing ring *B* and the punch, as it descends, draws it down and compresses it to the shape of the punch *C*. The shell, which now resembles the form shown at *B*, Fig. 12, is knocked out on the up-stroke by the engagement of stem *H* with the knockout bar, the same as in the first operation.

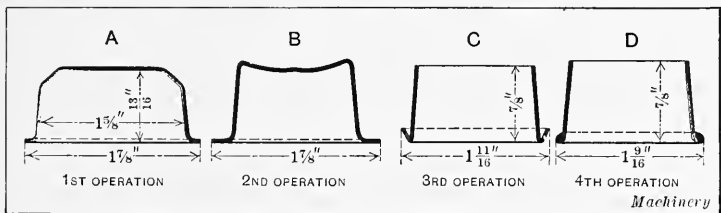

Fig. 12. Successive Operations Performed in Dies Illustrated in Figs. 8 to 11 Inclusive

The die for the third operation, which really consists of three operations, is illustrated in Fig. 10. The principal parts are the trimming die *B*; the center block *C*; the drawing ring *D*; the lower die *E*; and the tube *G*, through which the bottom of the nozzle passes after being punched out. Incidentally, these bottoms are used for roofing shells for fastening tar paper in place on roofs, etc., so that two articles are made at once. Inasmuch as these blanked out ends are to be utilized in this way, they are formed by pad *G* (Fig. 9) in the second operation. The die for the third operation is also used in an inclined press. As the punch *M* descends, it cuts out the bottom and at the same time punch *H* trims the flange. As the downward movement continues, the shell is pressed over the edge of center block *C*. When the punch moves upward the knockout bar comes in contact with stem *N*, thus forcing the cross-pin *K* and

stripper *J* down and ejecting the nozzle, which is now shaped as illustrated at *C*, Fig. 12.

The die for the fourth and finishing operation is illustrated in Fig. 11. This is of simple form and yet much depends upon it, because the nozzles all have to be of uniform size on the finished edge in order to receive a sealing cap, which, when closed, must be water-tight. The die has a bolster plate *A*; a die-block *B* of tool steel, hardened and tempered; and a punch *P* which is also hardened and tempered and ground out to fit a gage. In the operation of the die, the nozzle is slipped over the die-block *B*; as the punch descends, the recess at *F* engages the edge which was partially curled over in the preceding die, thus completing the curling operation and pressing it to the shape illustrated at *D*, Fig. 12. As the punch rises, the shell is ejected by an automatic knockout which is of the usual form.

**Drawing a Flanged and Tapered Shell.**—When drawing tapered shells with flanges, the requirements for the construction of the dies and the method of forming the shells are different than when drawing cylindrical shells, especially if the taper of the finished shell is large in comparison with the height and diameter. The blank should first be drawn into a cylindrical shape or one having a slight taper, the area being equal to that of the metal required in the finished shell. When trouble is experienced in drawing tapered shells, it is almost invariably caused by an attempt on the part of the diemaker to produce a “steep” taper in the first operation, or to draw a tapered shell directly from the flat blank. If this practice is followed, the shell may either split at the bottom or waves and wrinkles are formed which cannot be removed. Another frequent cause of trouble is due to a surplus of metal in the shell with the result that it cannot be distributed in the finishing operation or be returned to the flange from which it was drawn.

The successive operations in producing a flanged, tapered shell having diameters of  $1\frac{3}{8}$  inch and 1 inch at the large and small ends, respectively, and a depth of  $1\frac{7}{16}$  inch with a flange  $2\frac{3}{8}$  inches in diameter, are shown by the diagrams *A*, *B*, *C*, *D*, and *E*, in Fig. 13, together with the drawing dies. The flat blank

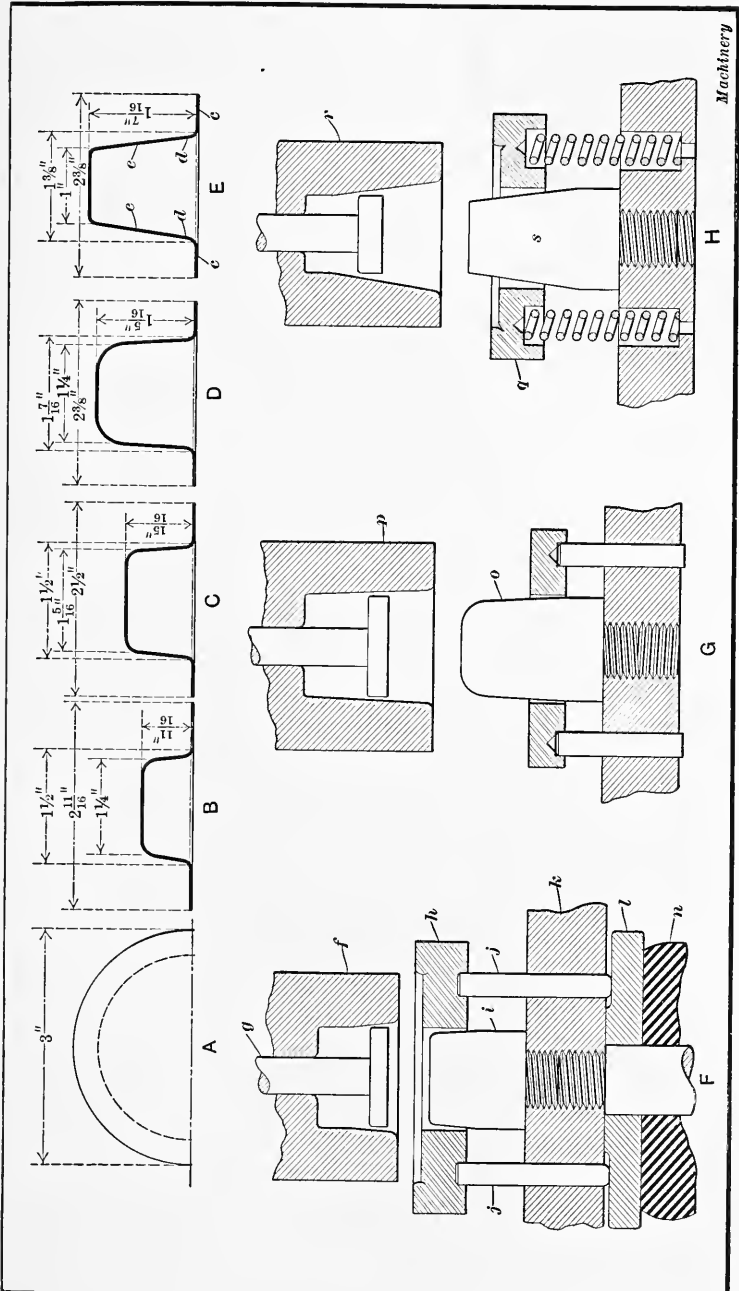

Fig. 13. Successive Operations on a Flanged Tapered Shell and Some of the Dies Used

*A* is, in three operations, drawn to shape *D*, which is slightly tapering, as the diagram shows. When the proper amount of metal is contained in the shell illustrated at *D*, a succeeding operation of re-forming — not drawing or reducing through friction — will shape the cylindrical shell to the desired taper, as indicated at *E*. The reason for this practice of keeping the shell cylindrical (or nearly so) until the last operation, is that in drawing a cylindrical shell or one that is slightly tapering, the metal is confined at all times during the process of drawing, between the die and punch surfaces, making the formation of wrinkles impossible and the flow of metal equal and constant during the entire operation. When the depth to be drawn is quite shallow, as compared with the depth of the shell diameter, even steep tapers can sometimes be drawn in one operation. In general, however, taper parts having a diameter at the bottom which is small in proportion to the extreme diameter of the flange, are difficult to draw, because of the formation of wrinkles and also because of the small area at the end of the drawing punch (in comparison with the large surface around the flange) and, consequently, the weakness of the metal at this point.

The blank *A* for producing the shape shown at *E* is 3 inches in diameter and 0.032 inch thick — No. 20 Brown & Sharpe gage. The blank was cut in a plain blanking die. The second operation *B* was done in the die shown at *F* and also the re-drawing operation *C*, the die remaining unchanged except that a thinner locating pad and blank-holder was substituted for the one shown at *h*. Referring to the sectional view *F*, the drawing die is at *f*; the shell knockout or ejector at *g*; the blank-holder and locater at *h*; the drawing punch at *i*; two of the five rubber pressure attachment pins at *j*; the die bolster at *k*; the top rubber pressure attachment washer at *l*; and the rubber "spring barrel" or pressure attachment at *n*. The die for producing the shape shown at *D* is illustrated at *G*. The cup *C* is located on the punch *o* and the die *p* descends and draws the cup to shape *D*. This die is also equipped with a rubber pressure attachment. In the finishing punch and die, illustrated at *H*, no drawing of the metal takes place, the wall of the shell being re-

shaped or formed in order to produce straight tapering sides. In the operation of this die, the shell  $D$  is located in a seat in the holder  $q$  and the die  $r$  descends, holding the flange of the shell tightly between the faces of  $q$  and  $r$  while the punch  $s$  forms the shell into the tapered shape. At the bottom of the stroke, pressure occurs on all the surfaces of the shell, thus producing a smooth tapered form.

Referring to the diagrams showing the evolution of the shell from the flat blank, it will be noted that at  $C$  an increase of  $\frac{1}{4}$  inch in height and  $\frac{1}{16}$  inch in top diameter is obtained. At  $D$  the height is increased to  $1\frac{5}{16}$  inch (a gain of  $\frac{3}{8}$  inch), whereas at  $E$  the shell is completed to a height of  $1\frac{7}{16}$  inch, the smallest diameter being 1 inch and the largest  $1\frac{3}{8}$  inch, as previously mentioned. The dotted line on the blank at  $A$  shows the amount of metal drawn from the blank in forming the cone of the shell at  $E$ . In producing this shell, the following changes take place in the thickness of the wall and flange. Referring to sketch  $E$ , the metal is reduced to 0.030 inch at  $c$ , to 0.022 inch at  $d$ , to 0.018 inch at  $e$ , and to 0.021 inch on the end or bottom of the shell.

It was necessary to anneal the shell after the first and third operations. To secure satisfactory results, annealing has to be done without producing a surface scale because the scale would impair the smoothness and accuracy of the finished product. Thin lard oil was used as a lubricant during the first two operations and then the shells were run dry and clean during the last two operations. None of the shells were fractured, and the tools shown in the illustration produced a large quantity. The drawing pads, punches, and rubber buffer pins used in the dies  $F$  and  $G$  were made of steel and the other parts of cast iron. For the finishing die  $H$ , steel was used throughout for the working parts and the pad and die surfaces were hardened and lapped. When drawing taper shells of the type referred to, in which a uniform thickness of metal throughout the wall of the shell is not necessary, a slight lack of metal in the cup next to the last operation is preferable, because the finishing tool can then stretch the metal so as to produce a smooth, true surface.

**Die for Drawing in a Single-acting Press.** — A die for drawing steel cups, such as would usually be made in a double-acting press, is shown in Fig. 14. No double-acting press was available, but only a long-stroke single-acting press of sufficient capacity to do the job. The die was made as follows: On the die *B* were bolted some U-shaped pieces *E* which carried the holding hooks *D*. These hooks *D* could be adjusted to any desired degree of tightness by setting down the pieces *E* with the set-screws provided and then clamping them securely in place.

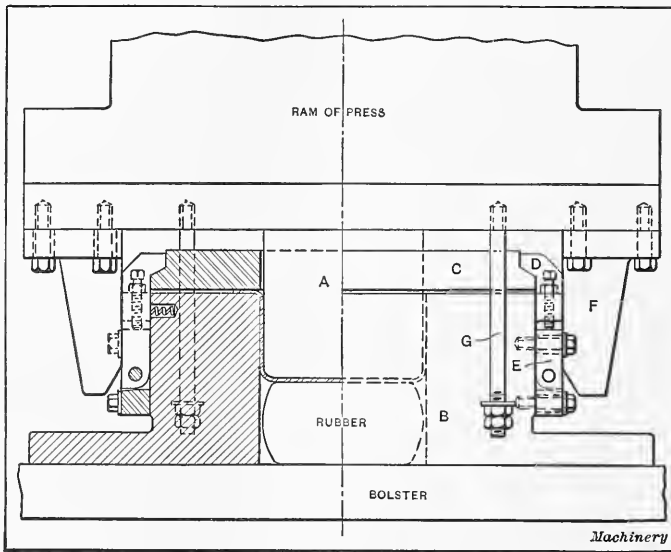

Fig. 14. Die for Drawing Cups in a Long-stroke Single-action Press

The blank-holder *C* was suspended on four bolts *G*, and these bolts were adjusted to the proper length so that the blank-holder *C* was laid on the blank early in the stroke; then closing lugs *F* engage the holding hooks *D* and force them in on the beveled ledge of the blank-holder. The lugs *F* then slide along the back of hooks *D* during the remainder of the stroke.

On the up-stroke the closing lugs leave the hooks *D* which are immediately thrown open by springs provided for this purpose, and then the blank-holder *C* is lifted up by the suspension bolts *G*. The formed piece is loosened in the die by the rubber block,



or, if necessary, a positive stripper can be provided. At first the closing lugs *F* were made solid with the punch-holder, but after several were broken by dirt or other foreign substances getting under the blank, a new holder was made with the lugs bolted on, so that the bolts would allow the lugs to give enough to prevent breakage. This die is more expensive than would

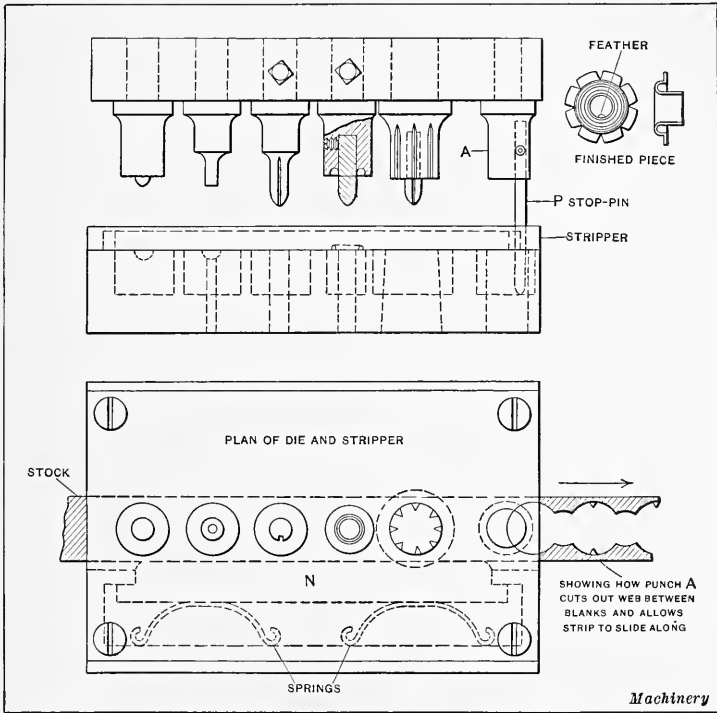

Fig. 15. Punch and Die for Performing Five Separate Operations

be required for a double-acting press, but makes it possible to do the work with the equipment at hand.

**Drawing, Forming, and Blanking Die.** — The die shown in Fig. 15 performs five distinct operations before the piece shown in the upper right-hand corner of the illustration is dropped completed from the press. In constructing this die it was not deemed practicable to make it of one solid piece, since one small flaw would, in this case, spoil the entire die. A die-block of machine steel was, therefore, used, having recesses counter-

bored for the insertion of tool steel bushings. In using a die containing two or more punches, considerable trouble is sometimes experienced on account of the variation in width of the stock to be punched. Should the stripper be planed to fit one of the strips of stock very nicely, the chances are that the next strip would not enter the stripper at all. The part *N*, shown in the plan of the die, enables this trouble to be overcome in a novel and practical way. The stripper is planed out  $\frac{1}{16}$  inch wider than the stock and recessed to allow the spring guide *N* to slide freely when the stripper is in position in the die. By glancing at the sketch the reader can readily see how the springs keep

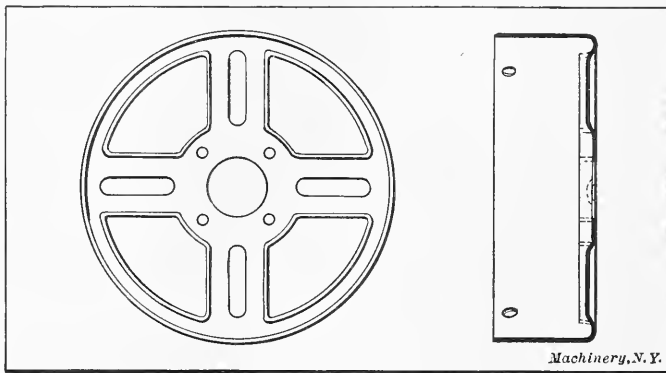

Fig. 16. Aluminum Shell Produced in Dies Illustrated in Figs. 17 to 19 Inclusive

the stock pressing against the gage side of the stripper. The punch *A* does not perform any work pertaining to the finished blank, but is used for cutting out the web in the stock in order to allow the strip to move along until the next web touches the stop-pin. As the stop-pin *P* does not come out of the stock it is therefore impossible to "jump" the stock and make a miscut, which would mean disaster to the drawing and forming punches.

After setting up the die in the press, the punches of course descend five times before a single finished piece appears, but thereafter a finished piece drops at each stroke of the press. The first punch, beginning at the left, indents the stock, and the punch is so adjusted that the face of the punch levels the stock. The second punch pierces the bottom of the indentation. The

next punch draws the stock, and at the same time forms a small feather along the hole in the finished piece. The fourth punch is the forming punch, and the last punch does the blanking.

**Blanking, Drawing, and Embossing Die.** — The spoked aluminum shell shown in Fig. 16 is about four inches in diameter and one inch deep. It has four spokes, or arms, radiating from a hub in which a shaft hole and four rivet holes are punched. These holes are used for attaching the aluminum shell to the bearings of the hub on which it is used. Stiffening “lips” are formed around the openings and spokes, and the ribs or spokes

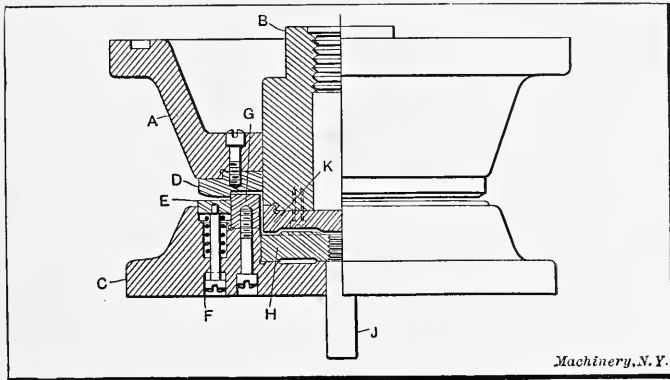

Fig. 17. Combination Blanking, Drawing and Embossing Die for Aluminum Shell

themselves are embossed to add to the strength of the shell. Four rivet holes punched through the rim of the shell serve to attach it to an exterior band.

This shell was made in the following manner and with excellent results: The blanking, drawing, and embossing is done in one operation in a double-action press, using the die shown in Fig. 17. The blank-holder *A* is made of cast iron, and a hardened tool-steel blanking die *D* is fastened to it, which not only acts as a die, but also serves to hold the blank in position while the drawing operation is taking place. *B* is the cast-iron drawing punch, to which is attached a hardened steel face *K*. This face *K* contains the embossing recess for the spokes, into which the metal is forced by the embossing punch *H* held to the lower

member. The punch *H* also acts as an ejector after the drawing and embossing operations have been completed, and is actuated by the stem *J* and the press knockout mechanism.

The die-shoe *C* is made of cast iron and is bored out to receive the blanking punch *G*, over the inner edge of which the shell is drawn after blanking. The stripper ring *E*, which is made of soft steel and passes around the periphery of the die *G*, is limited in its travel by the shouldered screws *F*, and is acted upon by six helical springs. There are several vent holes in the

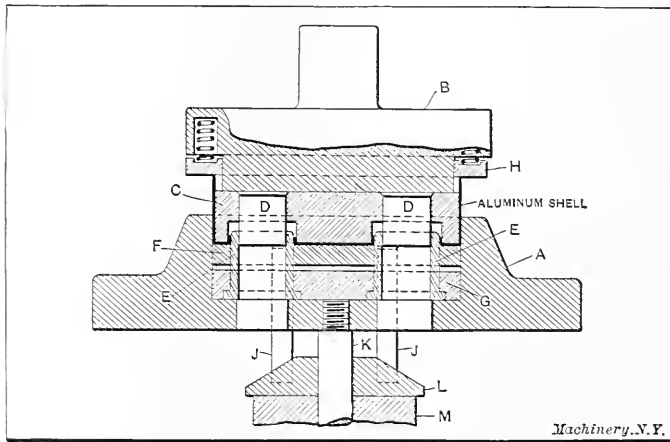

Fig. 18. Combination Piercing and Ribbing Dies

drawing punch and through the plate *H* and the base of the die-shoe, the purpose of which is to allow the air to escape while drawing, and enter while stripping and ejecting the shell. The shell is drawn entirely into the ring *G* and, of course, must be trimmed afterward. This is performed in a trimming lathe, although similar shells are sometimes drawn to the depth required, and a flange left on them, so that they may be trimmed off by a simple blanking die. However, the method of handling this operation lies entirely with the designer, although it should be governed to some extent by the requirements of the shell.

After the shell is drawn into cup form, the next operation is to blank the openings to form the spokes and turn up the "lips" around these openings. Both these operations are performed

in the die shown in Fig. 18, which is used in a single-action press. The die-shoe *A* and the punch-holder *B*, respectively, are made of cast iron, the die-shoe being bored out to receive the soft-steel die carrier *G* and the ejector plate *F*, which is also made of soft steel and is actuated by four studs *J* resting on a cast-iron plate *L*. This cast-iron plate *L* is pressed upward by a rubber pad *M* which slides on stud *K*. The die-bushings *E* are flanged on the bottom, as shown, and are held in the carrier plate in the usual manner. They serve not only as dies for piercing, but also as drawing punches to draw the stiffening "lips" on the shell. The drawing die *C* is held on the punch-holder *B*

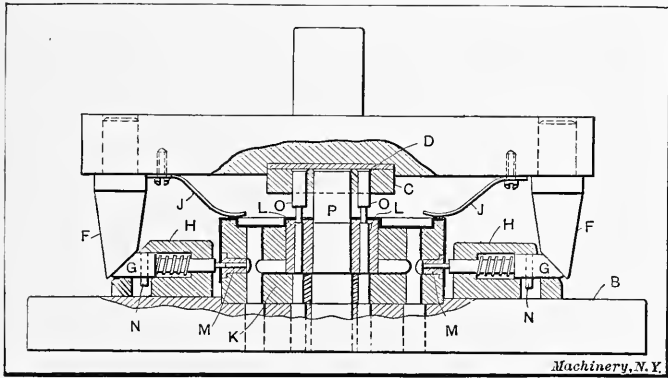

Fig. 19. Die for Piercing Holes in Sides and Bottom of Aluminum Shell Illustrated in Fig. 16

and carries the piercing punches *D*, which are set ahead of the drawing die so that they will pierce the stock before the die begins to draw the "lips." A stripper ring *H*, actuated by coil springs as shown, is limited in its travel by the drawing die *C* upon which it comes to rest on the up-stroke of the ram. All the screws and dowel-pins used for holding the various members in their respective holders are omitted for the sake of clearness.

The shell is now ready to have the holes around the rim and the small holes in the bottom pierced. These operations are done in the die shown in Fig. 19 which is used in a single-action press. A circular disk *B* of cast iron serves as a base for the press, and to it is attached the die-anvil *K*, of soft machine steel. Die-bushings *L* and *M* are driven into the anvil *K* for piercing

the holes in the rim and in the bottom of the shell. Recesses are cut in the block *K* to receive the "lips" around the spoke openings. The cast-iron punch-holder carries two flat springs *J*, which serve to hold the shell on the anvil when the holes are being pierced. The punch-holder also carries four studs *F* (only two of which are shown) that operate the piercing punches *G*. These piercing punches *G* fit in blocks *H* held to the die-bolster, and are retained in the blocks *H* by the small studs *N* working in elongated holes in the block. These small studs or pins *N* also serve to prevent the punches *G* from turning around, so that their beveled ends are always presented properly to the studs *F*. The punches *G* are withdrawn by coil springs, as shown, when the ram of the press ascends. The punches *O* and *P*, for piercing the holes in the bottom of the shell, are held in a machine-steel block *C*, which is backed up with a hardened tool-steel block *D* inserted in the punch-holder. The blocks *C* and *D* are doweled together and held to the punch-holder.

Making this aluminum shell in the manner described gives a uniform product, and the tools are of such a character that they are not very costly and are easily repaired. While these tools are of a special character, a number of the features incorporated in them could be used for a variety of purposes.

**Drawing Cartridge Cases.** — The drawing of cartridge cases from sheet brass requires some interesting tools and methods. The practice referred to in the following is that of the Frankford Arsenal, and covers more particularly the drawing of cases for 0.30 caliber cartridges. The first operation in the making of a cartridge case is to produce a cup, then by successive redrawing operations this cup is reduced in diameter and extended to the required length. Fig. 20 shows the various steps in the sequence of redrawing operations following that of making the cup. From this illustration it can be seen that five operations are necessary to bring the case to the required length. These are called redrawing operations because the work accomplished consists in reducing and redrawing a piece that has already been drawn to cup form. The press used for making the cups from which cartridge cases are made is of the double-action type, and

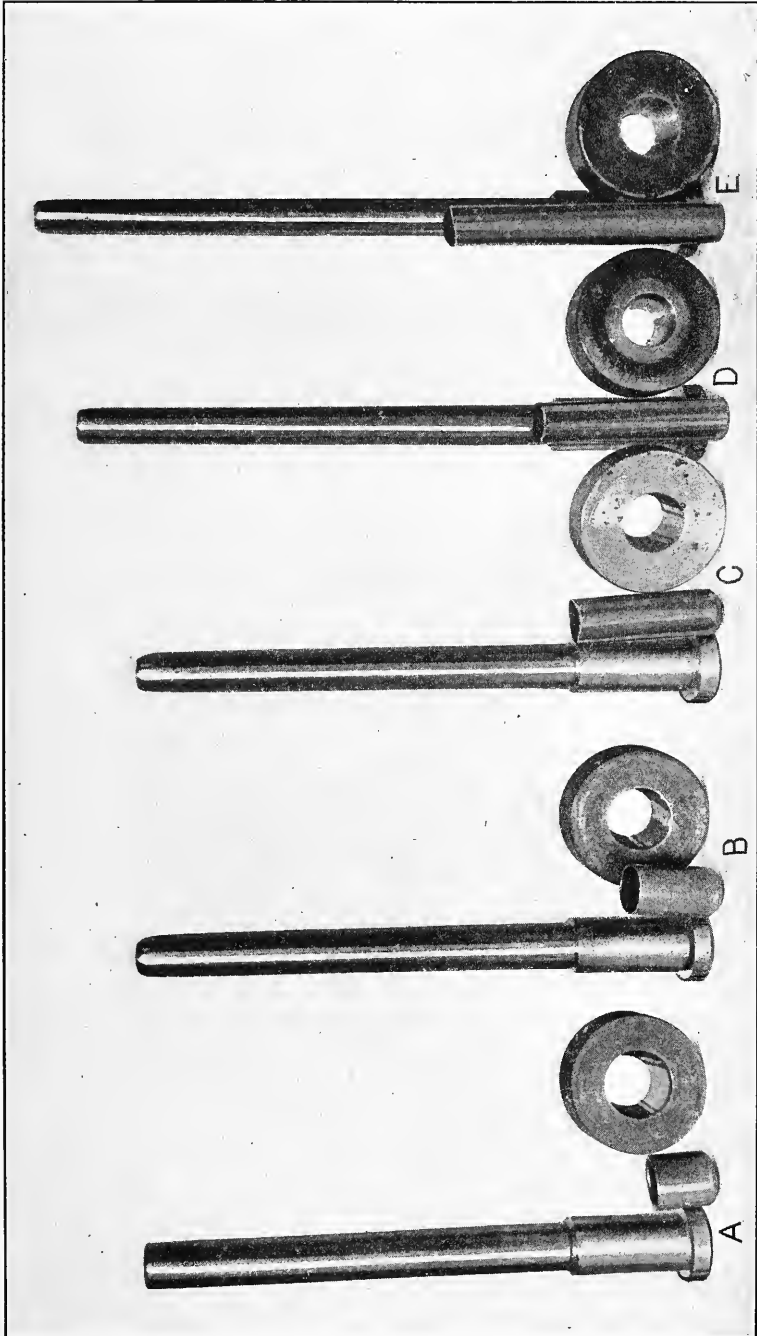

Fig. 20. Successive Redrawing Operations on 0.30 Caliber Cartridge Case — Punches and Dies Used

carries four punches and dies, thus making four cups at each stroke. This punch press operates at 100 revolutions per minute, producing 400 cups a minute, or 24,000 cups per hour. The type of blanking and cupping die used in this machine is shown diagrammatically in Fig. 21. At *A* the blanking punch is shown in contact with the top face of the brass sheet; at *B* the blanking punch has cut out a disk of the required size and carried it down to the first shoulder in the combination blanking, cupping, and drawing die; at *C* the drawing punch has come into operation and has started to form the blank to cup

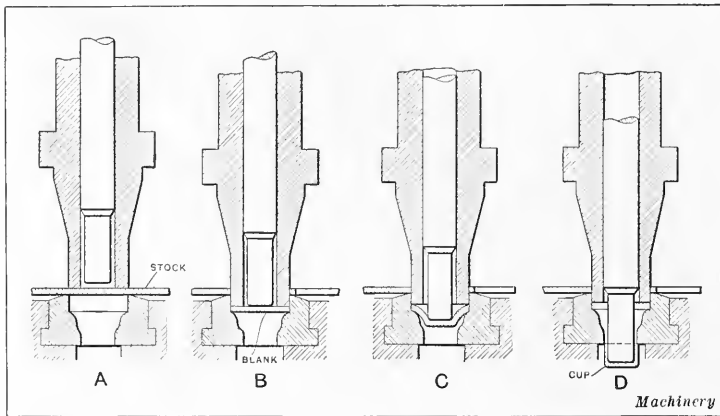

Fig. 21. Action of Blanking and Drawing Punch in Producing Cup from which Cartridge Case is Drawn

shape; and at *D* the blank has been forced completely through the die and has been given the first drawing operation.

The sheet stock is held on a roll located to the right of the machine and is drawn into the press under the blanking and drawing punches by means of feed rolls. After the stock passes through the rolls, it is oiled by means of a cloth saturated with lard oil.

**Redrawing Operations on Cartridge Cases.** — After the cups are made it is the general practice to anneal, wash, and dry them. Then they are ready for the first redrawing, or second drawing operation. The temperature to which the cup is heated for annealing varies from 1200 to 1220 degrees F. The manner of handling the cups after they have been annealed,



washed, and dried, is to carry them in trucks, which are lifted from the floor of the annealing room to a track located above the drawing presses. These trucks are provided with false bottoms and are run along the track until they are directly over the hopper which feeds the cups to the punch press. The false bottom is then removed, allowing the cups to drop from

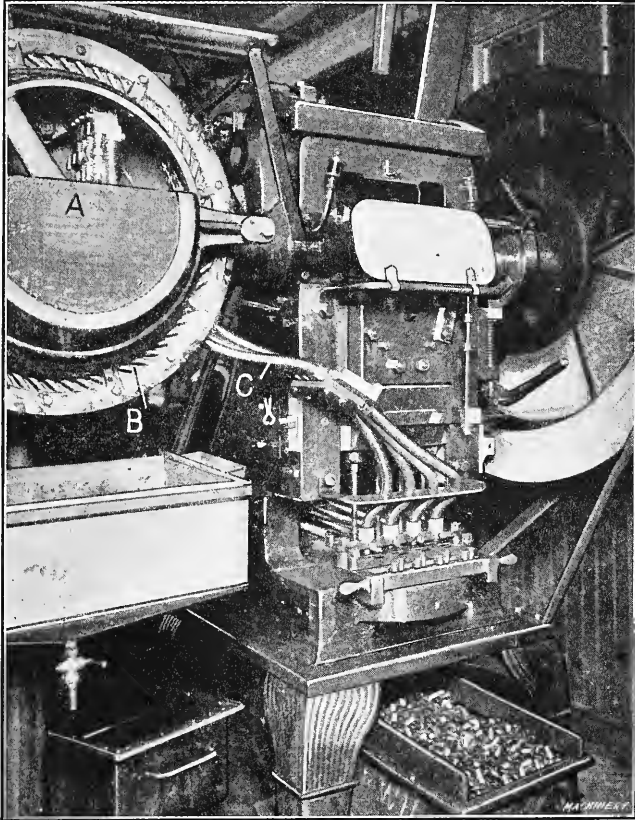

Fig. 22. Drawing Press Equipped with Four Dies and Operating on 24,000 Cartridge Cases Per Hour

the chute into the hopper *A* of the drawing press, Fig. 22, from which they are removed by a feeding device consisting of a wheel in which pins *B* are set at an angle of about 45 degrees with its horizontal axis. These pins are pointed, enabling the shell to be located on them mouth first. The pins are rotated

inside the hopper so that they catch the cups and deposit them in close-wound spring tubes *C*. These tubes pass from the hopper down to the feeding slides of the drawing press and as the shells drop out of the tubes they are caught by fingers held on the slides and carried over into line with the dies and punches.

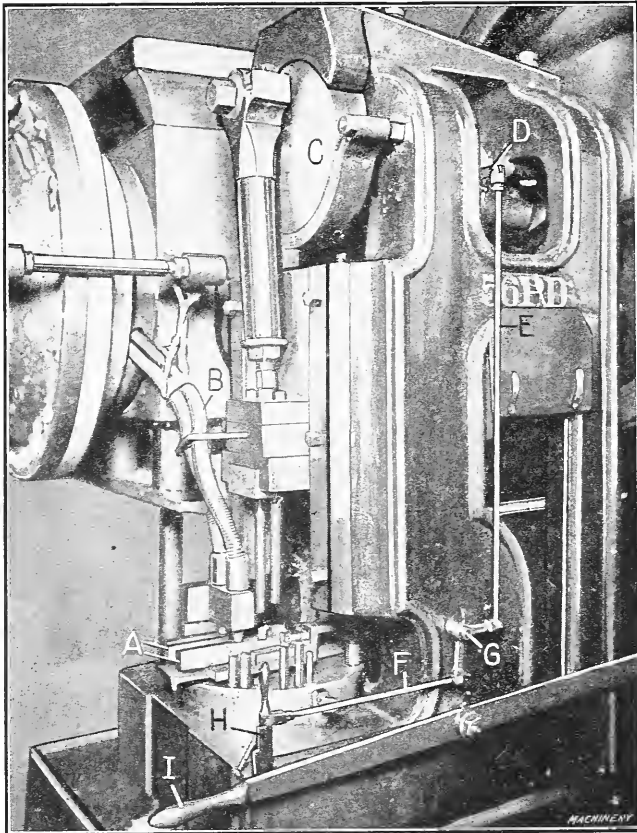

Fig. 23. Duplex Drawing Press for the Fourth Redrawing Operation  
— Capacity 10,800 Cups Per Hour

When the slides have advanced to their extreme forward positions, the punches descend and force the cups through the drawing dies, depositing them in a box located under the press. The slides are operated from the crankshaft through bevel gears and a connecting-rod that transmits power down to a horizontal

shaft carrying a series of four cams. These cams contact with rollers held in the feeding slides and thus transmit the desired movement to them. The rolls are held in contact with the cams by coil springs. The machine shown in Fig. 22 operates at 100 revolutions per minute, and as four cups are drawn per stroke, it is evident that this machine has a productive capacity of 24,000 cups per hour. The drawing press shown in this illustration is used for the second and third redrawing operations, shown with the die and punch used at *B* and *C* in Fig. 20.

The first, fourth, and fifth redrawing operations are handled in machines of a type similar to that shown in Fig. 23, which are provided with only two punches and dies instead of four, as was the case with the machine shown in Fig. 22. The feeding of the shells to the slide that carries them to the dies is practically identical with that shown in Fig. 22, but the slide is operated in a different manner. In this particular machine the slides *A*, which serve as a means for carrying the cups from the feeding tubes *B* over into line with the drawing dies, are actuated by means of a bellcrank lever receiving power from a cam held on the crankshaft *C* of the press.

While the shells are fed to the punch with the mouth up, it sometimes happens that one will pass down the feeding tubes to the slide the wrong way, that is, with the bottom up. Now should such a shell be allowed to pass over into line with the die, it would mean that the punch would be broken and the die either broken or damaged to such an extent that it would be unfitted for use. It is not uncommon also to have shells pass down to the slide, that are dented or otherwise defective thus preventing them from feeding into the die properly. Should such a shell pass down the feeding tubes and stick in one of the slides, it would mean that the punch would come down on the slide and break. In order to provide against such accidents, an ingenious tripping device has been applied to this machine and works very satisfactorily. This device, while comparatively simple in construction, is positive in its action, and has been the means of saving a lot of money in the cost of dies and tools. It also enables one operator to run four instead of two

machines. Essentially, this device consists of a projecting stud which is held in the crankshaft of the press, and, when the feeding slide is operating normally, passes through a slot cut in a lever that is connected with the bellcrank lever operating the slide. Now, if for any reason the slide should be prevented from making a complete forward or backward stroke, this projecting pin would not pass through the slot in the lever mentioned, but would force the lever out, knocking out the lever *D*, which transmits a movement through the links *E* and *F* and bellcrank *G* down to the tripping lever *H*. This knocks the clutch operating lever *I* off the catch — throwing out the clutch and

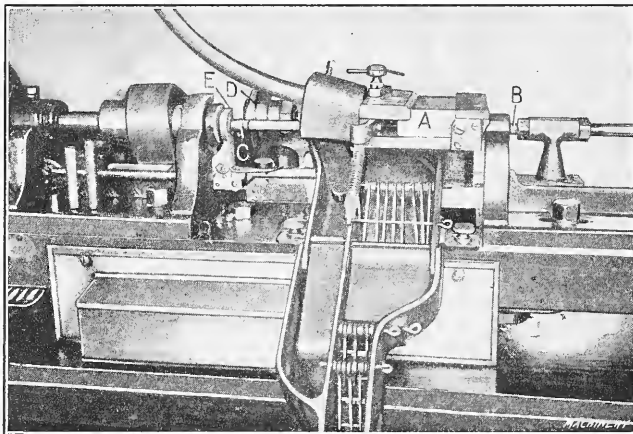

Fig. 24. Automatic Trimming Machine for Cartridge Cases

stopping the press. It can therefore be seen that this tripping device is of simple construction, but is effective, owing to the fact that when the slide does not complete its movement the clutch is thrown out before the ram of the press reaches the top of the stroke, so that the machine is stopped before it has a chance to complete another stroke.

**Final Redrawing Operation.** — The fifth redrawing operation is accomplished in a press equipped similarly to that shown in Fig. 23. These presses operate at 100 revolutions per minute and turn out 12,000 cups per hour. Several annealing operations take place between the time when the cup leaves the first redrawing operation and the time when it is ready for trimming.

Before the fourth redrawing operation is done, the shells are taken to a heading machine of the horizontal type where they are "bumped," in order that in the successive redrawing operations the head of the shell will not be reduced too much in thickness. The 0.30 caliber cartridge case has what is known as a solid head; that is, the top portion of the shell that contains the primer is not indented to form a pocket for the primer, the pocket itself being simply a hole forced into the head. This type of cartridge has been found necessary for use with smokeless powders. The former method used in making 0.30 caliber cartridge cases was to form the pocket by forcing in the head, which was very little thicker than the sides of the shell near the head. This construction, however, was found to be too weak for smokeless powders, as the head would blow off. The "bumping" is a very simple operation and is somewhat similar to heading except that the punch is perfectly flat and simply gives the shell a blow, upsetting it slightly and flattening it so that in the two final redrawing operations — fourth and fifth — the metal at the head is not stretched to any appreciable extent.

**Trimming a Cartridge Case to Length.** — It is practically impossible to draw a shell that does not have an irregular top edge and also one that is not distorted or cracked to some extent. This makes it necessary to draw the case much longer than actually required and to trim off the surplus material. The removal of this excess amount of stock is done in machines that are operated automatically. These trimming machines are arranged in such a manner that the various hoppers can be filled from an overhead conveying system. This arrangement consists of a track similar to that used in the drawing press department previously referred to, and enables one man to attend to an entire line of presses. The track accommodates a truck in which the shells are carted along the line and from which they are ejected through a false bottom, dropping into the hoppers located over the machines. The feeding of the shells down to the trimmer is effected by the same type of hopper as previously described, but the subsequent handling is somewhat different. As the shell descends from the hopper it passes

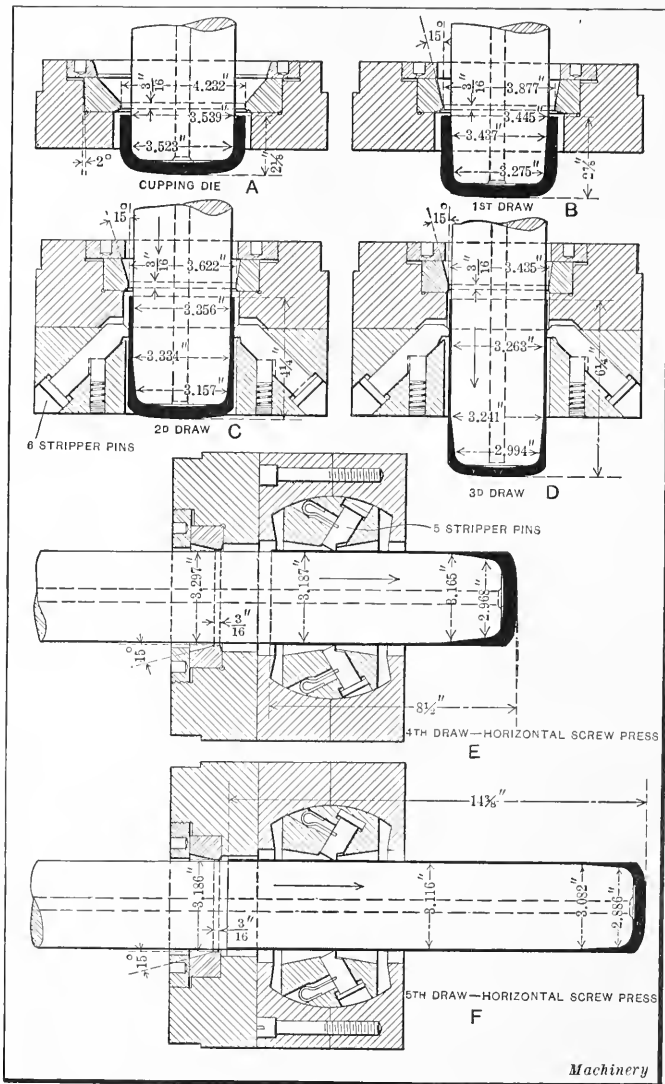

Fig. 25. Dies Used for Drawing 3-inch Brass Shrapnel Cases

through a locating cage *A*, Fig. 24, from which it is carried forward by a plunger *B* and is located on the cutting-off punch *C*. Here it is held by friction while a circular trimming tool *D* advances and trims off the surplus stock. The shell and trim-

ming are then ejected from the cutting-off punch by a sleeve *E* operated from the left-hand end of the machine, the shell being deposited in one box and the trimming in another; two separate channels are provided as shown.

**Drawing a Brass Shrapnel Case.** — The dies used for drawing a 3-inch brass shrapnel case are illustrated in Fig. 25, as well as the successive operations. The shallow cup which is drawn from the flat blank is indicated by the heavy black line at *A*. This cup is next reduced in diameter from 4.232 inches to 3.877 inches in the die illustrated at *B*. The second redrawing operation is illustrated at *C*. The case is now drawn out to such a length that stripping pins or fingers are used to remove it from the punch. As will be seen, these pins are inclined and recede against the tension of springs as the shell passes down, and then engage the top edge as the punch ascends. There are six of these stripper pins equally spaced around the base of the die. The die *D* for the next operation is similar to the one just referred to except that it is somewhat smaller in diameter. The fourth and fifth redrawing operations are done in horizontal screw presses because the length to which the case is drawn exceeds the stroke of the vertical presses. As the illustration shows the stripper pins in these dies are mounted in a holder having a spherical bearing, so that it has a limited movement in any direction. As the result of this universal movement, the stripper pins automatically adjust themselves to conform to any unevenness of the edge of the drawn case; consequently, a practically uniform pressure is exerted upon the case when it is being moved from the punch. The case is annealed after every drawing operation and it is reduced to an outside diameter of 3.186 inches, and lengthened to  $14\frac{3}{8}$  inches. All of the punches are tapered on the end in order to secure thicker walls near the end, as indicated by the illustrations.

**Multiple Drawing Die of Indexing Type.** — The upper and lower members of a multiple drawing die for performing six drawing operations at one stroke of the press are shown in Figs. 26 and 27. The lower member, Fig. 27, contains the punches and is equipped with an automatic indexing mechanism

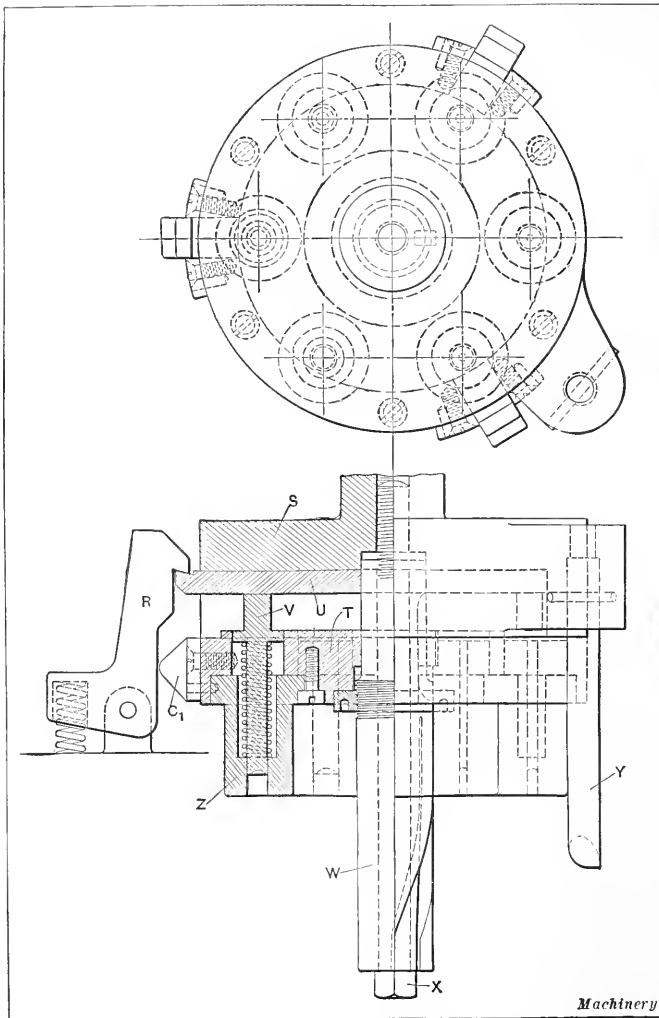

Fig. 26. Upper Member of Multiple Drawing Die

which serves to carry the work around so that it is acted upon by the six punches and dies which successively reduce the size of the drawn part. Inasmuch as all of the punches and dies operate simultaneously, evidently a drawn piece is produced at each stroke of the press. Eight operations are required to complete the drawn part and their successive order is indicated in



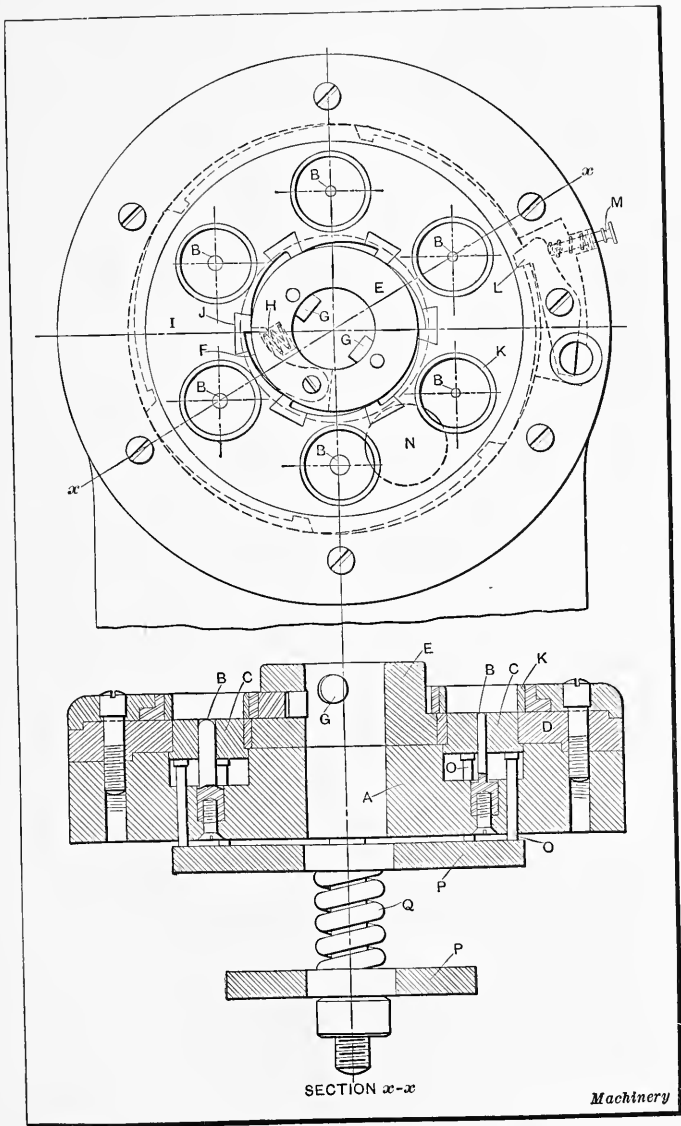

Fig. 27. Lower Member of Multiple Drawing Die

Fig. 28. The first operation is done in a compound blanking and drawing die equipped with a roll feed; the six operations following are performed in the automatic indexing die, which is

shown in the accompanying illustration, and the eighth or final operation, which consists of turning down a flange and leveling the bottom, is done in another separate die.

The automatic indexing die has a shoe *A* which rests on the bolster of the press and serves to hold six equally-spaced drawing punches *B* and their respective stripping collars *C*. These stripping collars are held in place by retaining ring *D* which also provides a bearing for pawl carrier *E*. This carrier is hardened and ground and has attached to it a pawl *F* (see plan view) and also two hardened pins *G* which engage spiral grooves formed in extension *W* of the upper member (see Fig. 26). The pawl *F*

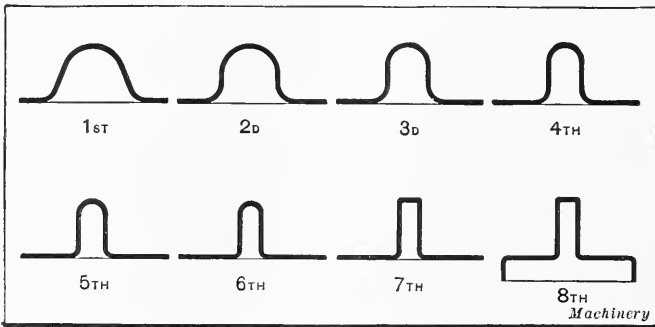

Fig. 28. Successive Drawing Operations, Six of which are done in Multiple Die of Automatic Indexing Type

is normally held outward by spring *H* and engages hardened teeth *J* inserted in plate *I*. These teeth take the end-thrust of pawl *F* as the latter, with plate *E*, is revolved when the press ram ascends. Plate *I*, which is the index plate, has six holes into which are pressed the hardened bushings *K*. On the periphery of this plate there are six slots which are engaged by the end of locating lever *L* which serves to hold the plate firmly in position and locate the work accurately relative to the drawing dies. The thumb-nut *M* connecting with lever *L* is used for disengaging the lever when it is desired to turn the index plate by hand, in case it is necessary to remove the drawn parts.

During one revolution of plate *I* each of the six holes passes over the clearance hole *N*, which is just beyond the final drawing die, thus allowing the drawn part to drop out of the die and into

a box beneath the press. The stripping collars *C* for the punches are actuated by three springs *Q* that are located on a circle underneath plate *P* and are held in position by three studs. These springs normally hold plate *P* upward and also collars *C*, by means of pins *O*.

The steel plate *T* (Fig. 26) is held to punch-holder *S* by screws and serves as the holder for the six drawing dies *Z*. Between holder *S* and plate *P* a space is cored out to receive stripper plate *U* which rests upon the strippers *V*. (The action of this plate will be referred to later.) The driver *W* has two spiral grooves milled into it which engage pins *G* (see Fig. 27) and operate the pawl carrier as previously mentioned. The bolt *X* provides adjustment for this driver. The hardened rod *Y* serves to release the locating lever *L* on the lower member so that index plate *I* may be revolved.

The operation of the dies is as follows: When the upper member descends, the successive drawing operations on the six parts are performed (assuming that the die is completely loaded) and at the same time plate *E* and index pawl *F* are turned backward into engagement with the next tooth *J* on plate *I* preparatory to indexing. The rod *Y* also engages the end of locating lever *L* and withdraws it from the index plate. When the upper member ascends the drawn parts are stripped from the punches and dies, and plate *E*, with index pawl *F*, is turned forward, thus indexing the six drawn pieces from one die to the next by the rotation of index plate *I*. When lever *L* is released by the upward movement of rod *Y* it drops into a notch and accurately locates and locks the index plate in position. This cycle of movements is repeated for each stroke of the press.

In designing this die, one of the points which had to be considered very carefully was to secure a rapid and positive stripping action for the dies in the upper members; in fact, the drawn parts have to be stripped from the dies as soon as the press slide starts upwards so that the work will not be disarranged by being carried up out of the index plate. This positive stripping action was effected by means of plate *U* in conjunction with three levers or pawls *R*. These levers are pivoted to the lower

member and as the upper member descends they are forced outwards by three cams  $C_1$ . At the end of the downward movement, levers  $R$  are in engagement with plate  $U$ , as the illustration, Fig. 26, indicates. When the slide begins to ascend, plate  $U$  and the strippers  $V$  are held stationary while the dies  $Z$  move upward, thus ejecting the drawn parts. When the cam surface on lever  $R$  is engaged by cam  $C_1$ , it is forced outward, thus releasing plate  $U$ . In this way the strippers are actuated at the beginning of the upward stroke so that the drawn parts are pushed from the dies without leaving the index plate. As the slide continues to ascend the index plate is revolved into position for the next drawing operation.

**Dies for Rectangular Drawing.** — Dies of the combination and double-action types are used for drawing rectangular and square shapes and, in some cases, special designs are employed, particularly if the part must be drawn to considerable depth and only a single-acting press is available. The principal difficulty connected with using a single-acting press is in the arrangement of the blank-holder or pressure-pad on the die. A common method is to attach the drawing die to the ram of the press and support the punch below; the pressure-pad extends around the punch and rests upon pins which pass through the press bed and bear against a plate which is backed up by a rubber buffer or spring pressure attachment that can be adjusted to give the pressure required. This arrangement is satisfactory for many classes of work, but when drawing comparatively deep parts it is objectionable in that the blank-holder pressure increases as the die descends. Consequently, if this pressure is sufficient for the beginning of the drawing operation, it will be excessive at the end of the downward stroke. This defect is sometimes remedied by using extra long springs or buffers or a special compensating attachment.

For deep drawing, when a single-acting press is to be used, a die equipped with a pressure-pad of the type shown in Fig. 29 is preferred by some diemakers. The die and die-shoe rest upon the bolster of the press and into the latter are screwed two shoulder studs  $S$  having coarse threads onto which are fitted

the handled nuts *N*. These nuts serve to hold down the pressure pad which is pivoted on one of the studs and slotted to receive the other so that it can be swung out of the way. (See plan view.) The underside of the pad is faced with a hardened tool-steel plate about  $\frac{1}{4}$  inch thick. When using the die, the pressure-pad is swung out, the blank placed in position and then the pad is swung back and tightened by nuts *N*. After a few parts have been drawn, the operator will be able to determine how much

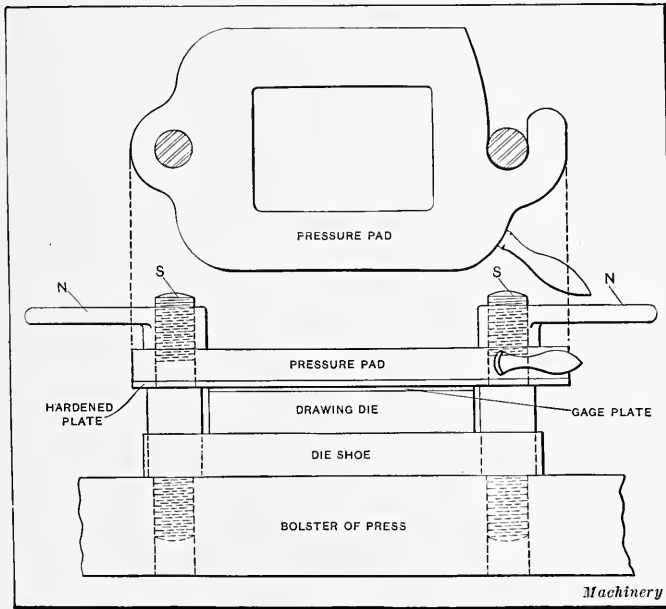

Fig. 29. Rectangular Drawing Die Equipped with Hand-operated Blank-holder for Use in Single-action Press

these nuts should be tightened to prevent wrinkling. The heavier and more rigid the studs and pad are the less tightening is necessary, because the object is simply to confine the metal before it goes into the die so that wrinkling will be impossible. This form of die has proved satisfactory and it is similar in effect to the action of the double-acting press.

**Blank-holder Pressure Compensating Attachment.** — The principal reason why ordinary combination dies cannot draw as deeply as double-action dies is that the pressure between the

drawing die and pressure-pad gradually increases as the part is drawn, as previously explained, owing to the increased compression of the drawing rubber or spring-pressure attachment. The result is that the stress upon the metal being drawn increases rapidly as the drawing die descends, because the stress due to the drawing operation is unduly increased by the excessive pressure on the outer part of the blank. In other words, if the pressure upon the blank is sufficient at the beginning of the drawing operation, it rapidly rises as the pressure-pad or "drawing rubber" is compressed. On the other hand, when the pressure on the blank is practically uniform, as in the case of a double-action die, a somewhat greater depth may be obtained in one draw, assuming that the same material is used in each case and that other conditions are equal.

In order to prevent an increase in pressure between the die and blank-holder, some combination dies are equipped with a compensating attachment. This attachment has a cross-bar under the table which carries the rubber pressure-pad. This bar extends outward at each side and vertical pins are attached to the ends and pass up through the press table. When the ram of the press descends, it begins to force these compensating pins downward as soon as the required blank-holder pressure is obtained. As the pins move downward, they also lower the cross-bar and rubber pressure-pad and, therefore, the blank-holder pressure does not increase. In other words, when there is sufficient pressure on the blank, the compensating pins are engaged by the slide and as the drawing operation continues, the blank-holder pressure remains practically constant, because the drawing rubber is carried down at the same rate as the press slide. The screws on the slide which engage the compensating pins are adjustable so that the pressure-pad can be compressed the required amount before the compensating attachment comes into action. While this attachment has been used in many cases where it was desired to obtain an exceptionally deep draw in a combination die, the results obtained have not been altogether satisfactory, because it has been found difficult to obtain a uniform pressure on the blank; moreover, the compensating

attachment is rather cumbersome and complicates the construction.

**Combination Die for Deep Drawing.** — In order to avoid the use of a compensating attachment, the Nelson Tool Co., Inc., of New York, designed a combination die that is especially adapted for comparatively deep drawing operations and is simple in construction. An example of the work done in this die is illustrated in Fig. 30, which shows the flat blank and also the rectangular case which is drawn in one operation. The stock is aluminum,

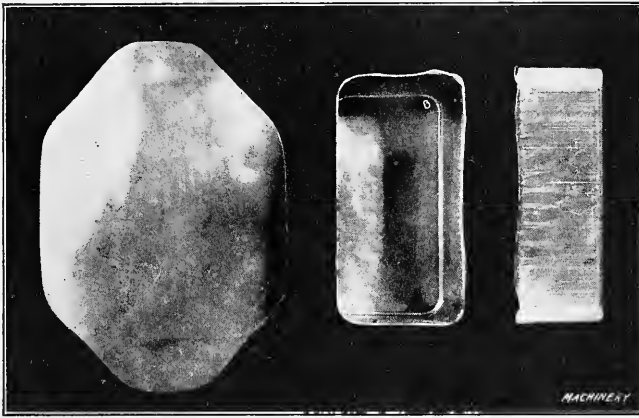

Fig. 30. Blank and Rectangular Case Drawn from it in a Combination Die

0.050 inch thick, and the case is  $4\frac{1}{4}$  inches wide,  $8\frac{9}{16}$  inches long and is drawn to a depth of  $2\frac{3}{16}$  inches. In order to draw to this depth in one operation in a combination die and avoid the excessive increase in blank-holder pressure, four steel pressure strips *A* were attached to the blank-holder near the corners of the blank, as indicated in Fig. 31, which shows a detailed view of the die. These strips are the same thickness as the stock and they are engaged by the die during the drawing operation. The result is that while the blank is confined between the die and blank-holder, it is not subjected to an appreciable increase in pressure as the die descends, because the steel strips hold the die in a fixed position relative to the blank-holder. By this simple method, the increase in pressure resulting from the compression of the drawing rubber is not transmitted to the blank;

the latter is merely confined between the flat surfaces of the die and blank-holder which are positively held a fixed distance apart. As the plan view to the right shows, the four pressure strips are so located on the blank-holder as to form a "nest" for the blank.

The use of these pressure strips or distance pieces between the die and blank-holder not only simplifies the construction of the die but, in this particular instance, enables the required depth of  $2\frac{1}{16}$  inches to be drawn in one operation. At first, ex-

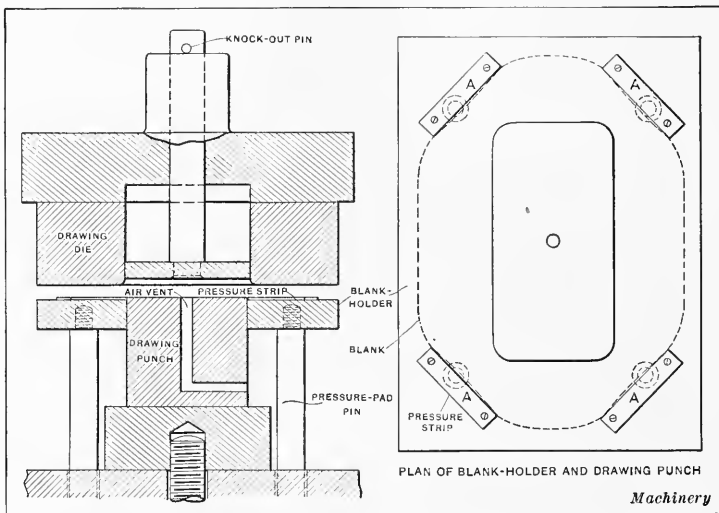

Fig. 31. Combination Die Used for Operation Illustrated in Fig. 30

periments were made with pressure strips 0.012 inch thicker than the aluminum stock. While the results were fairly satisfactory, there was slight wrinkling. When strips of the same thickness as the stock were used, however, the aluminum cases were drawn without difficulty, and are a fine example of rectangular drawing. The radius of the corners of the case is  $\frac{1}{16}$  inch, whereas the radius at the bottom, on the inside, is  $\frac{3}{32}$  inch, which, of course, corresponds to the radius of the drawing punch. The drawing edge of the die has a radius of  $\frac{1}{4}$  inch, or five times the stock thickness. Located within the drawing die, there is a knockout which is operated by a cross-bar in the usual manner,



at the upper end of the stroke. The drawing punch is provided with an air vent hole in the center to prevent the formation of a partial vacuum under the case when the latter is being stripped from the punch. The blanks are cut out in a separate blanking die.

A die equipped with inserted corner pieces is shown in Fig. 32. This form is sometimes used when a large number of steel parts have to be drawn. This construction allows the corners to be replaced when worn and they can be made much harder than if they were a part of a solid die. This design also permits

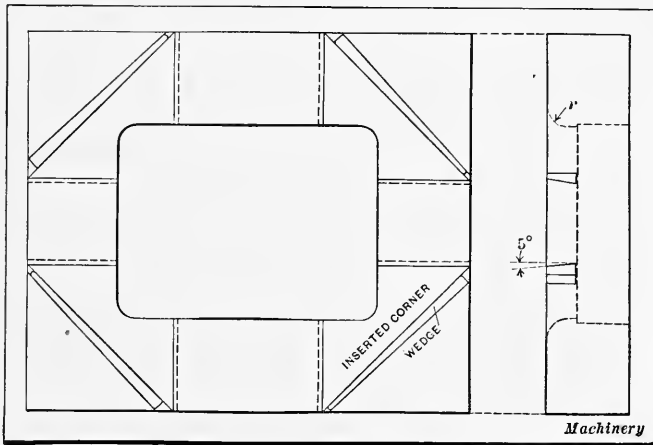

Fig. 32. Rectangular Drawing Die Provided with Inserted Corner Pieces

the use of expensive steel, such as high-speed steel, for these corner pieces. This form of die is not recommended for small work. The particular die illustrated was designed for drawing steel parts 6 by 8 inches in size and it has outworn several sets of corner pieces.

**Drawing Rectangular Shapes.** — When making dies for drawing rectangular and square shapes, the first thing to consider is the form of the part to be drawn. This point is often overlooked by the designer, as all he may have in mind is to produce a box of a certain size. Therefore, he may specify a radius of  $\frac{1}{8}$  inch at the corner of the box when the radius could just as well be  $\frac{1}{2}$  inch, and perhaps the radius at the lower corner or

edge could also be larger than is specified. This matter of corner and edge radius is important and may greatly affect the drawing operation. The kind of metal to be used should also be considered. It is often more profitable to make small parts of brass than of steel because there is less wear on the dies and fewer spoiled parts. When steel is necessary and the depth of the draw exceeds one-half the width of the box, a "deep drawing" steel should be used. A deep drawing steel which has proved satisfactory contains from 0.08 to 0.18 per cent carbon (preferably about 0.10 to 0.12 per cent); about 0.35 per cent manganese, with the percentage of phosphorus and sulphur less than 0.03 per cent. It is advisable to be on the safe side when deciding what thickness of metal to use; that is, it is preferable to use a little extra metal and have ample strength at the lower edge of the box, where the greatest strain from drawing occurs, than to use a metal that is barely strong enough to withstand the drawing operation. This is especially true if the part must be drawn to considerable depth. When using brass and aluminum, the cost of the material is an important factor and it is common practice to begin with stock, say,  $\frac{1}{8}$  inch thick; this original thickness is retained in the first draw but is reduced in each succeeding draw so that, when the box is finished, the sides will be considerably thinner than the bottom. With this method, less metal may be used or, in other words, a smaller blank than if the box were made of uniform thickness. The reduction of thickness at each draw should not exceed 0.0025 inch on a side. Thinning the sides in this way is not considered practicable when using steel, owing to the comparative cheapness of steel and the increase in wear on the dies which would result from "ironing" or thinning the stock.

**Laying Out Rectangular Dies.** — After having carefully considered the design of the part to be drawn and the material from which it is to be made, the next step is that of laying out the die or dies, as the case may be. There are several fundamental points that should be considered before proceeding with the laying out operation. For instance, there may be some doubt as to the practicability of drawing a box in one operation, and

one might naturally suppose that by employing two operations many difficulties would be avoided, because the work is divided between two dies. There may, however, be more trouble when using two dies, especially if steel is to be drawn, because the drawing operation is confined to the corners, and forming the sides of the box is nothing more than a folding or bending operation; consequently the dies wear principally in the corners and as the result of this wear and increase of clearance space, the metal thickens at the corners. In some cases the metal will thicken to such an extent as to make it impossible to push the work through the second die when two are employed, without rupturing the box at the corners. Moreover, when there are two operations, annealing may be required between the draws, and if this is done in an open fire oxidation takes place which would require a pickling operation to free the part from scale. Even though a closed furnace is used, the parts should be washed to free them from grit as otherwise the die would be lapped out very quickly. If there is no doubt as to whether a part should be drawn in one die or two, it is advisable to first make the finishing die and attempt to produce the part in one operation. If this trial draw shows that one die is not practicable, then the first-operation die can be made.

The amount of clearance at the corners is another important point. By allowing a little more than the thickness of the metal between the punch and die at the corners, the pressure required for drawing is considerably reduced. For instance, if stock 0.0625 inch thick were being used, a space of about 0.067 inch should be left at the corners; this clearance is advisable for a one-operation die and also for the final die of a series. The top surface of a first-operation die should be perfectly flat and smooth. If this surface is ground the grinding marks should be polished out as otherwise the pressure of the blank-holder will tend to hold certain parts of the blank more than others, causing an uneven draw. The corners of the die, as well as the punch, should be made very hard.

The radius of the drawing edge should be uniform and the surface smooth. The edge radius of the first drawing die (as-

suming that more than one operation is required) is the most important. Theoretically, this radius should be as large as possible but it is restricted for the reason that the larger the drawing radius the sooner the blank is released from under the blank-holder or pressure-pad, and if this release occurs too soon, the metal will wrinkle; if wrinkling occurs, a fractured corner is liable to be the result. It is also important to make the corner radius as large as possible. When the corner radius does not exceed  $\frac{3}{4}$  inch, the radius of the drawing edge of the first die should be about the same as the corner radius, whereas for a corner radius exceeding  $\frac{3}{4}$  inch, a drawing edge radius of  $\frac{3}{4}$  inch should be retained.

**Determining Number of Drawing Operations.** — When laying out rectangular dies, naturally one of the first things to consider is the number of operations required to complete the box or whatever part is to be drawn. The number of operations is governed by several factors such, for instance, as the quality of material, its thickness, the corner radius and also the radius at the bottom edge of the drawn part. In some cases, this lower edge can be rounded considerably, whereas in others it must be nearly square; obviously, when the corner is sharp a fracture at this point is more liable to occur owing to the pull of the drawing punch. Because of these variable conditions no definite rule can be given for determining the number of operations, although the following information will serve as a general guide.

When drawing brass, it is safe to assume that the part can be drawn to a depth equal to six times the corner radius. Suppose a box is to be drawn that is 5 inches wide, 6 inches long and 3 inches deep, and that the corner radius is  $\frac{1}{2}$  inch, and the lower edge rounded to about  $\frac{1}{4}$  inch radius. By applying the foregoing rule we find that this can be done in one operation; thus, the depth equals six times the corner radius, or  $6 \times \frac{1}{2} = 3$  inches. If the corners were of  $\frac{1}{4}$  inch radius, then two operations would be required. The larger the radius the greater the depth which can be obtained in the first draw. However, when the corner radius exceeds about  $\frac{1}{2}$  inch, the maximum depth should be somewhat less than six times the corner radius. A general idea

of the maximum depths for corners of given radii may be obtained from the following figures taken from actual practice: With a radius of  $\frac{3}{32}$  to  $\frac{3}{16}$  inch, depth of draw, 1 inch; radius  $\frac{3}{16}$  to  $\frac{3}{8}$  inch, depth,  $1\frac{1}{2}$  inch; radius  $\frac{3}{8}$  to  $\frac{1}{4}$  inch, depth, 2 inches; radius  $\frac{1}{2}$  to  $\frac{3}{4}$  inch, depth, 3 inches.

When two dies are required the first die should have a corner radius equal to about five times the corner radius of the finished part. The relation between the corners of the first and second dies is indicated by the diagram A, Fig. 33. As will be seen they are not laid off from the same center but so that there will

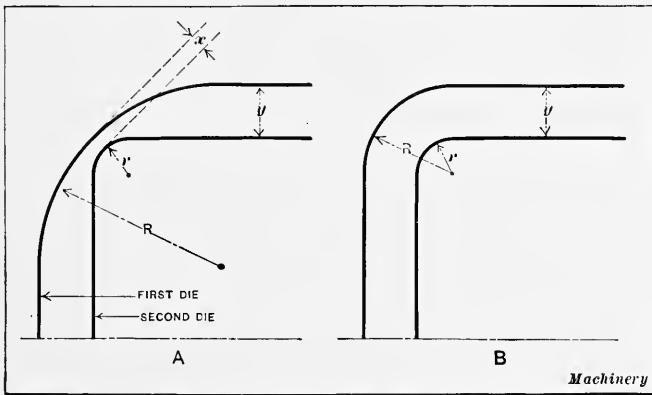

Fig. 33. Diagrams Showing Relation Between the Corners of First- and Second-operation Dies for Square or Rectangular Work

be enough surface  $x$  between the two corners to provide a drawing edge. The reason for selecting such a large corner radius for the first die is that when these large corners are reduced to the smaller radius in the second die, a large part of this compressed metal is forced out into the sides of the box. Now if the first die were laid out as indicated at B or from the same center as the second die, there would be a comparatively large reduction at the corner and, consequently, the metal would be more compressed and the drawing operation made much more difficult, because, as previously mentioned, the drawing action is confined to the corners when drawing rectangular work. Sometimes dies are made as indicated at B but the reduction necessary in the second operation is liable to result in fracturing the

metal. The radius of the first die should be laid out from a center that will leave a surface  $x$  (see sketch *A*) about  $\frac{1}{8}$  inch wide, although this width should be varied somewhat, depending upon the size of the die.

The amount  $y$  that a rectangular part can be reduced between draws depends upon the corner radius and diminishes as the corner radius becomes smaller. For instance, a box with corners of  $\frac{1}{8}$  inch radius could not be reduced as much as one with corners of  $\frac{3}{8}$  inch radius. To obtain the total amount of reduction or  $2y$ , multiply the corner radius required for the drawn box by 3; then add the product to the width and length, thus obtaining the width and length of the preceding die. This rule should only be applied when the corner radius is less than  $\frac{1}{2}$  inch. For all radii above  $\frac{1}{2}$  inch, simply multiply the constant 0.5 by 3 in order to obtain the total reduction. Suppose a box is to be drawn that is 5 inches wide, 6 inches long,  $\frac{1}{8}$  inch corner radius, and we desire to establish the size of the first-operation die. By applying the rule just given, we have  $\frac{1}{8} \times 3 + 5 = 5\frac{3}{8}$  inches, and  $\frac{1}{8} \times 3 + 6 = 6\frac{3}{8}$  inches. Therefore, the die should be made  $5\frac{3}{8}$  inches by  $6\frac{3}{8}$  inches. As previously mentioned, the corner radius for the first-operation die should be about four times the corner radius of the finished part; hence the radius in this case would equal  $\frac{1}{8} \times 4 = \frac{1}{2}$  inch. In this way, the number of operations required to draw a rectangular part are determined. After the drawing dies are completed, the shape of the blank must be determined. While a blank can be laid out which would be approximately the required shape, the exact form must be determined by trial before the blanking die can be made.

**Shape of Blanks for Rectangular Work.** — When a rectangular part is to be drawn, it is common practice to cut out a trial blank having a width equal to the required width of the drawn part at the bottom plus the height of each side, and a length approximately equal to the length of the drawn part plus the height at each end. The rectangular blank thus obtained is beveled and rounded at the corners until by repeated trial “draws” the correct shape is obtained. The simple method to

be described will make it possible to secure the required blank shape in a more direct and accurate way. It is not claimed that the dimensions obtained will be absolutely correct or close enough for the final dimensions of the blanking punch. This method will, however, enable the diemaker to determine quickly the approximate shape for the blank, and the results will be sufficiently accurate to eliminate many trial drawing operations, thus saving considerable time.

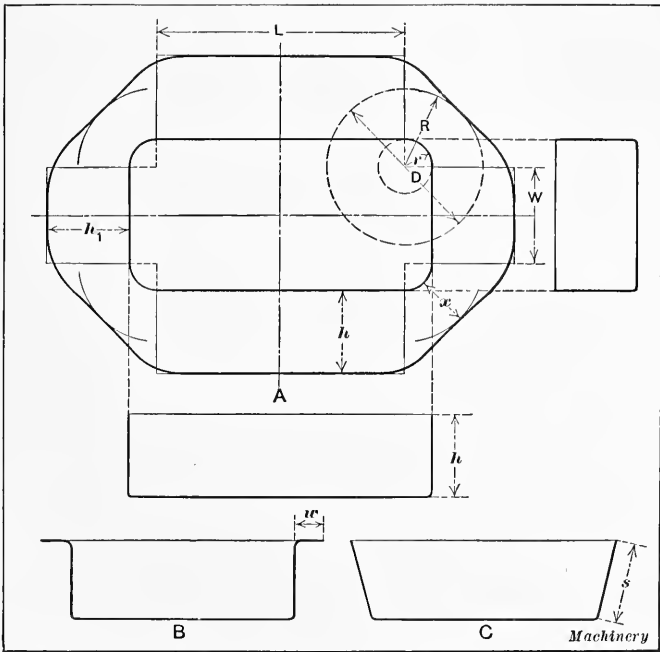

Fig. 34. Diagram Illustrating Method of Determining Approximate Shape of Blanks for Drawn Rectangular Parts

When laying out a blank by this method, first draw a plan view of the finished shell or lines representing the shape of the work at the bottom, the corners being given the required radius, as shown by the diagram *A*, Fig. 34. Next draw the sides and ends, making the length  $L$  and the width  $W$  equal to the length and width of the drawn part minus twice the radius  $r$  at the corners. We now have a blank which would produce a rectangular piece without corners. To provide just the right

amount of material for the corners is the chief problem, which may readily be solved. The first step is to find what blank diameter would be required to draw a cylindrical shell having a radius  $r$ . This diameter can be obtained by the well-known formula  $D = \sqrt{d^2 + 4dh}$ , in which  $D$  = blank diameter;  $d$  = diameter of drawn shell; and  $h$  = height of shell. This formula may be expressed as a rule as follows: Multiply the diameter of the finished shell by the height; then multiply the product by 4, and add the result to the square of the finished shell diameter. The square root of the sum thus obtained equals the blank diameter. After determining the diameter  $D$  (see Fig. 34) scribe arcs at each corner having a radius  $R$  equal to one-half of diameter  $D$ . The outline of the blank for the rectangular part is then obtained by drawing curved lines between the ends and the sides, as indicated by the illustration. These curves should touch the arcs  $R$ . The exact shape of the curve depends somewhat upon the proportions of the drawn part but it can readily be determined by drawing a few trial blanks and making whatever changes may be necessary to secure a more even edge along the top of the drawn part.

It will be noted that the width  $x$  at the corner is considerably less than the width or height  $h$  at the side and, at first thought, one not experienced in rectangular drawing might naturally suppose that there would be insufficient metal at the corner. It must be remembered, however, that the stock in passing through the die tends to fold and wrinkle at the corners, but as there is insufficient space between the punch and die to prevent wrinkling, the metal is packed up or upset and is forced upward, thus increasing the height of the corner so that the upper edge is about the same height as the sides and end. If the drawn part is quite narrow in proportion to the length, the dimensions  $h_1$  at the ends of the blank should be slightly less than the height required for the work, because the metal tends to stretch more at the ends, thus increasing the height.

After laying out the trial blank, as described in the foregoing, and trimming or cutting the edge to conform with the outline obtained, the shape of the blank should be transferred to an-



other piece of the same stock. The trial blank is then drawn and the outline showing its shape prior to the drawing operation serves as a record and enables the diemaker to see what changes in the outline should be made in order to secure a more even edge along the top of the drawn rectangular part. When a blank of the correct shape is obtained, it is used in laying out the blanking die. Of course, if the part must be drawn quite deeply, it is not feasible to secure an even edge along the top and the usual practice is to finish this edge by the use of trimming shears or a separate trimming die.

When laying out the blank, it is often advisable not to attempt to secure a shape that will form corners that are level with the sides of the drawn part but rather a form of blank that will produce corners that are a little higher than the sides. This is desirable because the wear on the die is at the corners and when wear occurs the metal will thicken and then the drawn part will be low at the corners provided that no allowance were made on the blank.

**Blanks for Rectangular Flanged Shells.** — When a flange is to be left on a drawn rectangular part, the shape of the blank may be determined in practically the same way as described in the foregoing, except that the width of the flange must be considered. Referring to Fig. 34, the dimensions  $h$  and  $h_1$  on the flat blank are made equal to the height of the drawn part plus the width  $w$  of the flange (see sketch *B*); whereas, the radius  $R$  at the corners should be established from the formula for a shell of radius  $r$ , having a flange corresponding to the width required. The blank diameter for a cylindrical shell having a flange can be determined by the formula  $D = \sqrt{d_2^2 + 4 d_1 h}$ , in which  $D$  = blank diameter;  $d_1$  = diameter of the drawn shell;  $d_2$  = diameter measured across the flange; and  $h$  = height of shell. After determining diameter  $D$  and the corresponding radius  $R$ , the outline of the blank is drawn the same as for a rectangular shape without the flange.

**Blank for Rectangular Tapering Shell.** — If a rectangular part is to have tapering or slanting sides, the dimensions  $h$  and  $h_1$  (see plan view *A*, Fig. 34) should be made equal to the slant

height  $s$  or the height measured along the slanting surface as indicated by the diagram  $C$ . To determine the blank radius  $R$  at the corners, find the blank diameter for a tapering shell corresponding to the size of the corners. This diameter  $D = \sqrt{d_1^2 + 2s(d_1 + d_2)}$ , in which  $D$  = blank diameter;  $d_1$  = diameter of drawn shell at bottom;  $d_2$  = diameter at top; and  $s$  = slant height. The radius  $R$  is made equal to  $\frac{1}{2} D$  and then the outline of the blank is drawn as previously described for a plain rectangular part. If the work should have slanting sides and a flange, the width of the flange should, of course, be added to the slant height and radius  $R$  established from the formula for a flanged tapering shell. This formula is as follows:  $D = \sqrt{d_1^2 + 2s(d_1 + d_2) + d_3 - d_2^2}$ , in which  $D$  = blank diameter;  $d_1$  = diameter of drawn shell at bottom;  $d_2$  = diameter at top;  $d_3$  = diameter across flange; and  $s$  = slant height.

**Blanks for Elliptical Shapes.** — The establishing of blanks for drawn parts of elliptical or oval shapes requires a little more time than laying out the blanks for rectangular shells. In order to determine the outline of the blank for an elliptical shell, first lay out an ellipse of the same size as the bottom of the drawn part, as shown in Fig. 35. Then draw a rectangle  $a-b-c-d$  and a diagonal line  $a-d$ . Next draw from corner  $b$  a line  $b-g$  perpendicular to  $a-d$ ; the intersection of line  $b-g$  with the center-line  $x-x$  locates center  $D$ , and the intersection with center-line  $y-y$  locates center  $C$ . Now determine what blank radius  $R$  would be required for a plain cylindrical shell of radius  $C-a$  and height  $h$ ; then draw arcs having a radius  $R$  corresponding to the blank radius, from the centers  $C$  and  $C_1$ . In a similar manner, determine the blank radius  $r$  for a plain cylindrical shell of radius  $D-d$  and height  $h$ . Then draw an arc having a radius  $r$  and also an arc  $r_1$  at the opposite end. We now have the major or longer axis  $L$  and the minor or shorter axis  $W$  of the elliptical blank. The ellipse representing the outline of the blank is then drawn through points located by the well-known method, which is partially illustrated by the dotted lines. The method is briefly as follows: Two circles are first described with  $c$  as a center and  $W$  and  $L$  as diameters. A



surface condition of the dies and the physical properties of the metal being drawn.

**Trimming Drawn Rectangular Parts.**—After a square or rectangular part is drawn, it is necessary to trim the edges unless the depth of the draw is comparatively small, as in the case of can or box covers, etc. There are several ways of trimming the edges in a punch press. If the box is square it can be placed on a fixture of the type shown in Fig. 36 and be trimmed by cutting the four sides successively, the work being indexed by turning spindle *B*. Each cut should overlap the other by a small margin to insure a smooth even edge. The spindle *B* is

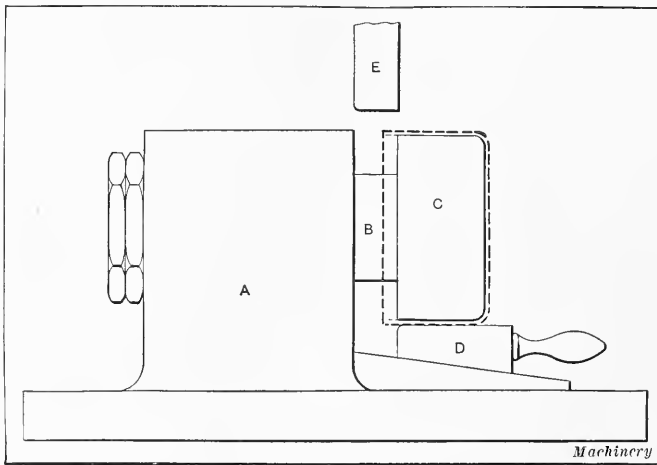

Fig. 36. Fixture for Trimming Edges of Drawn Parts

a running fit in the main casting *A* and holds the hardened tool-steel knife *C*. The dotted lines show the position of the box to be trimmed. As shown, a tapered wedge *D* which slides in under the lower side of the box serves to locate it and also to take the downward thrust of the cut. The blade or knife *E*, which is attached to the ram of the press, may be ground square across the end or at a slight angle on the cutting face; a slight amount of angle or rake is desirable when trimming thick stock. If the part to be trimmed is rectangular, the length of the knife should be equal to the length of the longest side of the box minus the radius of one of the corners. For instance, a box 5

by 6 inches having a  $\frac{1}{2}$  inch corner radius should be trimmed with a knife  $5\frac{1}{2}$  inches long. The two long sides should be cut first because if the short sides were cut first, there would be a tendency to distort the corners. When the sides are unequal, the wedge *D* should either be double-ended or have enough taper to compensate for the difference in the box dimensions.

Another method of trimming is shown in Fig. 37. In this case, two sides are cut simultaneously so that only one indexing is required. This method is satisfactory for soft metal

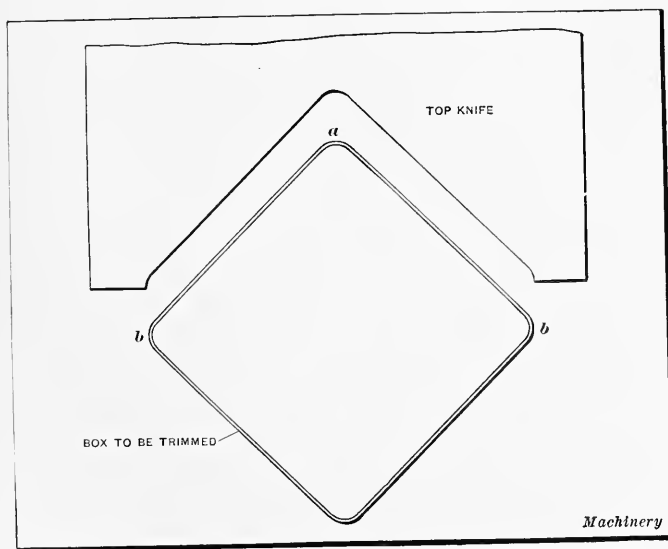

Fig. 37. Form of Punch which Trims the Two Sides of Drawn Boxes Simultaneously

such as brass or aluminum but is liable to cause trouble when trimming steel, because the corners are so hardened, as the result of drawing, that the top corner *a* might split from the strain of the cut, unless the box were annealed for trimming. The fixture for indexing and supporting the work is similar to the form illustrated in Fig. 36.

**Points on Drawing and Forming Die Construction.** — Some of the most common causes of trouble in the operation and construction of drawing dies will be referred to. Care should be taken that a shell which is the first of a series of operations is

uniform in height all around, because a little unevenness will multiply as it passes through succeeding dies, thus requiring a larger blank than is necessary. This defect is often caused by the blanking ring not being concentric with the drawing die; the blank-holder may also bear harder on one side than on the other or a bad burr on one side of the blank may result in holding that side back. If the bottom of the shell breaks out, this may be caused by using a die that is too small in relation to the blank diameter. The rule usually employed for cylindrical work is that a shell may be drawn to a depth equal to its diameter. Very often this depth may be exceeded somewhat but the strength of the bottom of the shell will be reduced for succeeding draws. Other causes of fracture at the bottom of the shell are too small a drawing radius, insufficient clearance between the punch and die, excessive blank-holder pressure, excessive friction between the blank-holder and die, caused by grinding marks on either die or blank-holder, and inferior quality of drawing metal.

The straight or cylindrical surface below the curved drawing edge of the die should not be too long because the pressure exerted on the metal when it is being drawn over the rounded edge tends to remove most of the lubrication, thus leaving very little for the straight surface; consequently, a scored shell is liable to be the result if the cylindrical part of the die is too long. The length of this straight part usually varies from  $\frac{1}{4}$  to  $\frac{1}{2}$  inch. The diameters of the punch and die should be measured occasionally to determine the width of the clearance space. If, as the result of wear, this clearance becomes excessive, the metal will thicken to such an extent that there will be difficulty in connection with succeeding drawing operations. Any taper of the punch in an upward direction naturally would make it difficult to strip the drawn part. A vent hole through the center of the punch and opening to the atmosphere at some point above the top of the shell is also very important, as it prevents the formation of air pockets and facilitates stripping. The punch should always be polished in a lengthwise direction as this also aids in stripping the work.

When determining the size of the blank for an irregular or rectangular shape, always begin by making the blank a little smaller than what is expected to be the required size. Then if fracturing occurs, it is very evident that a larger blank cannot be used, whereas if the blank is oversize a fracture may occur, thus leading to the conclusion that the draw is not practicable, although a proper sized blank might be drawn without difficulty. The corners of a rectangular shaped punch and die should be very hard, because most of the wear is in the corners. Care should be taken that the metal does not thicken up perceptibly during any one draw if others are to follow, but it is advisable to

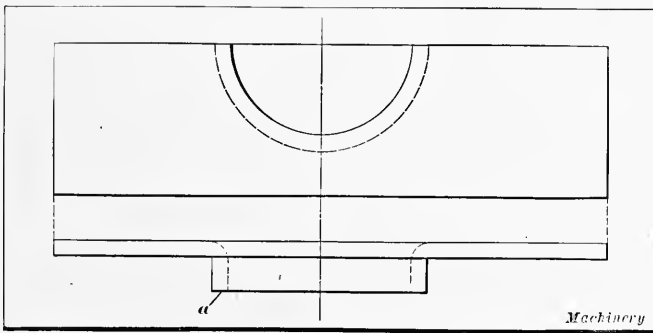

Fig. 38. A Drawn Cylindrical Projection

allow the corners to thicken slightly if there is only one operation or during the final operation of a series. To draw a cylindrical projection from a hole pierced in a flat blank, the hole should first be reamed out to prevent the lower edge *a*, Fig. 38, from splitting. This splitting at the edge when a hub is drawn without reaming the hole is doubtless due to the compression of the metal by the action of the punch, which causes splitting when the hole is expanded. When this compressed surface, however, is cut away by reaming, the stretching action does not have the same effect.

In forming blanks they should always be bent with the grain of the metal and not across it, particularly on sharp bends. By the "grain" is meant the way in which the metal was drawn when passing through the rolls. If it is required to make bends at right angles to each other or approximately so, the blanks

should be punched out diagonally across the grain. It is sometimes found necessary to form blanks from unannealed stock, that is, stock which has been rolled to a certain degree of hardness. In bending this metal it springs back more or less after being struck in the die. This makes it necessary to make a more acute angle, or a smaller radius on the punch and die, than is required on the finished product. This difference can be ascertained only by the cut-and-try method. When producing a short bend in blanks in such a position and of such a nature that the blank slips away from under the punch when it is descending into the die, a spring pad is fitted into the die with the lower part of the bend shaped into it, and flush with the top surface of the die. This holds the metal securely against the punch in its descent into the die and insures perfect duplicates of the product. Where holes in a blank come near a bend, a strain in the metal is set up during the bending operation which elongates the holes. This makes it necessary sometimes to pierce the holes slightly oval in the opposite direction before forming. In testing the shape of a forming die before it is hardened, always apply a small amount of oil to the surface so that the blank will not bruise or scratch the die, which would be the case if the die were left dry. Never leave the inside corners of a die sharp when they can just as easily conform to the radius formed by bending the stock around the punch. This will strengthen the die and lessen the possibility of its cracking when hardened.

When a punch or die is heated in a charcoal or a soft coal fire, the dust and ashes should be thoroughly scraped off the working portion before dipping, so that the water will have a free action upon the steel. Bending and forming dies, unless there is danger of cracking or breaking of weak parts, should be as hard as fire and water will make them. After hardening they may be warmed over a slow fire until water "sizzles" on them. Some toolmakers, when hardening a punch or die, apply cyanide of potassium to the working portions of the steel before dipping. They claim for this that the outer surface of the steel is rendered harder by the application of this casehardening substance and



thus will be better fitted to withstand the wear to which it is subjected. This practice is strongly condemned for this reason: If, as is often the case, the tool should fail to harden, this fact will be concealed by the casehardened outer coating, and the tool will respond to the file test as being hard whether it is or not.

Gage plates should never be secured with two screws and one dowel-pin. It is far more practical in most cases to use one screw and two dowel-pins. A good method of holding gage plates before their exact position is determined is to clamp them to the die with fillister screws having washers under their heads, and to drill the holes in the gage plate about  $\frac{1}{16}$  inch larger than the diameter of the screws, so that the gage plate may be shifted around. Always drill the screw holes for the gage plates through the die so that in case a new gage plate is required the holes will be spotted from the die. Whenever the gage plate comes close to the working portion of the die, cut the punch back far enough so that the body of the punch will come within  $\frac{1}{8}$  or  $\frac{1}{4}$  inch of the gage plate. In making gage plates for locating large blanks of irregular shape, they should be made to fit the blank only at the point where accuracy is essential, and not to conform exactly to the irregular shape of the blank.

When setting up a press for forming operations the blank as formed by the tools is used to locate the punch in the die before securing the die to the press. If the tools are being tried out for the first time and no sample has been made, they may be set with strips of metal cut from the stock to be formed. When setting the die for a piece in which the bends are not parallel but off at an angle, it is usually impracticable to set them with a previous blank, because, when the punch is brought down, the tendency is to push both die and blank away. The more practical method is to locate it approximately with the blank and slightly tighten the screws in the press bed; then with two strips of metal the same size as the blank, gage the exact distance, after which the die can be secured to the press. Do not assume that a die is certain to be satisfactory when the samples have been produced by bringing down the press slowly by hand,

as there is sometimes more or less variation in what the tools will do when operated by hand and when operated by power.

**“Alligator Skin” Effect on Drawn Sheet Metal.**— The peculiar mottled effect on the drawn sheet metal cup shown in Fig. 39 is known in the sheet metal industry as “alligator skin.” This marking is noticeable only when the metal is drawn or stretched to a considerable extent, as in the formation of a deep cup. There have been many reasons given for this effect. In producing cold-rolled strip steel, the material is annealed pre-

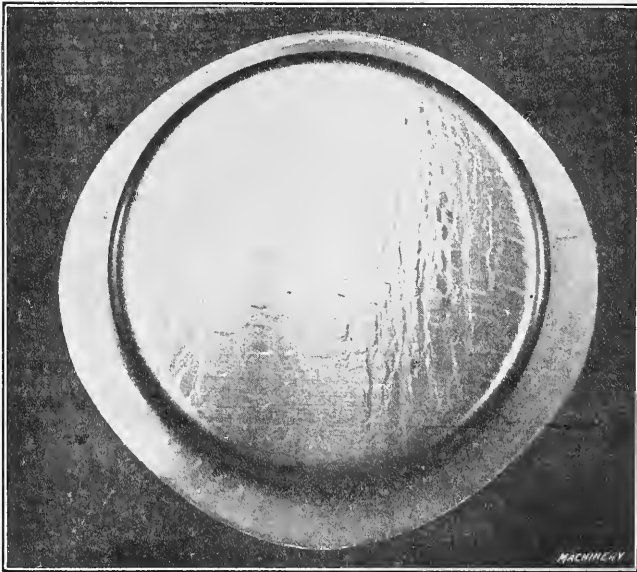

Fig. 39. Illustration Showing “Alligator Skin” Effect on a Cup Drawn from Steel having a “Skin Hard” Surface

vious to the last rolling operation, so as to eliminate brittleness as much as possible. The last rolling operation serves to brighten the metal and bring it to the correct thickness. For some work, however, it is necessary to secure a grade of sheet metal known as “skin hard.” This cold-rolled strip steel has a comparatively hard surface, and, when the skin is not too deep, produces bright and nicely finished cold-drawn work. However, it is much more difficult to work than the softer grades of steel, and is used only when a hardened surface on the material

is desired. It is when "skin hard" strip metal is being drawn up that the "alligator skin" effect is produced. If the metal, after annealing, is reduced too much in thickness in the final rolling operation, a hard surface is formed on the exterior which is much tougher than the interior; then, when the metal, in being worked up to the desired shape, is drawn to a considerable extent, the interior or center portion of the cup draws much more than the outer surface; hence the outer surface, or hard skin, pulls apart, as it will not stretch anywhere near as much as the inside. This leaves a peculiar looking surface slightly depressed in those portions where the skin has broken away. The particular cup shown in the illustration was drawn up from 0.037 inch sheet steel to a depth of  $1\frac{1}{2}$  inch and a diameter of  $3\frac{5}{16}$  inches; the partings of the skin vary from  $\frac{1}{16}$  to  $\frac{3}{32}$  inch in width in those portions where the metal has broken away to the greatest extent. It will be noticed in looking closely at this illustration that the markings are much finer at certain points than at others. This, no doubt, was due to imperfect alignment of the die and punch, which caused the metal to be drawn more on one side than on the other.

It might be mentioned here that this "alligator skin," effect very seldom appears on soft sheet steel but is quite often present on "skin hard" steel. Manufacturers often find that this "skin hard" metal comes mixed up with soft stock, indicating that the rolling mill is at fault in allowing too much reduction in the final rolling operation.

**Rubber Pressure-Pads.** — The rubber pressure-pads used on some types of drawing dies for supplying the necessary pressure to the blank-holder should be built up of separate sections instead of being formed of one solid piece of rubber, provided a comparatively large size is required. One advantage of the sectional form is that the smaller sections will not "settle" and lose their resiliency as soon as the large solid piece of rubber, because the smaller sections are of better quality. The use of sections also makes it convenient to build up the pressure-pad until the required size is obtained. The sections can also be utilized on different dies in many cases.

## CHAPTER IV

### BENDING AND CURLING DIES

While it is possible, in certain cases, to bend articles during the operation of punching, it is usually necessary to make a separate operation of bending. It is sometimes possible to make the dies so that the various operations can be done in different parts of the same die-block, the piece of work being changed from one portion to another in order, as the various operations are gone through. At other times it is necessary to make several sets of bending dies, the number depending on the number of operations necessary. When a given quantity of work has been run through the first die, it is removed from the press and the next in order placed in, so continuing until the work has been brought to the desired shape. When a comparatively small number of pieces are to be bent to a shape that would require a complicated and, consequently, costly die, in order that the bend might be made in one operation, it is sometimes considered advisable to make two dies for the operation, which are more simple in form and inexpensive to make. At times the design of the press is such that a complicated die could not be used; and, consequently, dies of a simpler form, which can be fitted in the press, must be made.

**Simple Types of Bending Dies.** — We will first consider the simpler forms of bending dies. The diagram *A*, Fig. 1, represents a die used in bending a piece of steel *a* to a V-shape, as at *b*. In the case of a die of this form it is necessary to provide an impression of the proper shape as shown; this impression, if the die is to be used for bending stiff stock, must be of a more acute angle than if stock having little tendency to spring back when bent to shape is used. Under ordinary circumstances the upper portion or punch would be made of the same angle as the die. It is necessary to provide guides and stops to locate the

work properly. If the stock used in making the pieces is of a high grade and the product is a spring or similar article which must be hardened, it will be found necessary to cut away the die somewhat in the bottom of the impression, to prevent

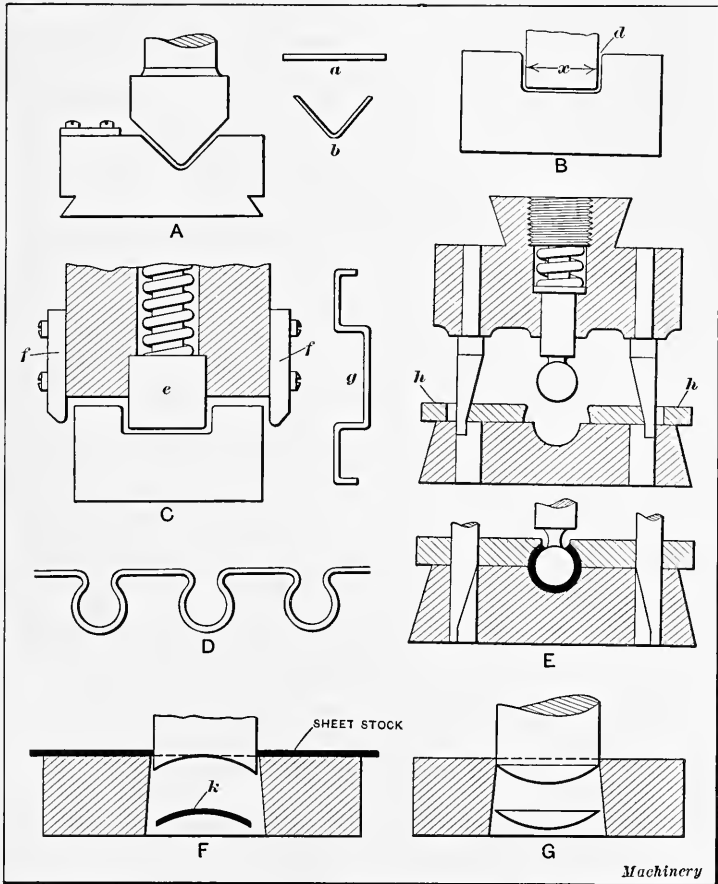

Fig. 1. Simple Types of Bending Dies

crushing or disarranging the grain of the steel to an extent that would cause it to break when in use. If the die is of the form shown at B, the width  $x$  of the punch should be slightly less than the width of the die minus twice the thickness of the stock. If possible, the upper corners  $d$  of the die should be rounded

somewhat, as the stock bends much easier and with less danger of mutilating the surface than when the corners are sharp. When bending thin ductile metal the corners need but little rounding; if the stock is thick or very stiff, a greater amount of rounding is needed.

When bending articles of certain shapes, it is necessary to design the tools so that certain sections of the piece will be bent before other portions. If an attempt were made to make the tools solid and do the work at one stroke of the press, the piece of stock would be held rigidly at certain points and it would be necessary to stretch the stock in order to make it conform to other portions of the die. In the case of articles made from soft stock, this might be accomplished, but the stock would be thinner and narrower where it stretched; however, as a rule, it is not advisable to do this, and dies are constructed to do away with this trouble. Diagram *C*, Fig. 1, represents a die, the upper part of which has a plunger *e* that engages the stock first. After forcing it down into the impression, in the lower portion, part *e* recedes into the slot provided for it. The coil spring shown is sufficiently strong to overcome the resistance of the stock until it strikes the bottom of the impression; then the side plates *f* engage the outer ends of the stock and bend it, thus forming the article shown at *g*.

Compound bending dies are used very extensively on certain classes of work, especially in making looped wire connections and articles of thin sheet stock. The sectional views *E*, Fig. 1, show a die used for bending a bow spring. As the punch descends, the stock is bent down into the impression in the lower half and forms the stock to a circular shape. As the end of the punch with the stock comes into contact with the bottom of the impression, the punch is forced upward, the spring keeping it against the stock, while movable slides *h* are pressed in by means of the wedge-shaped pins so as to force the upper ends of the loop against the sides of the punch, as shown by the lower view. When the punch ascends, the finished loop may be drawn off. If the stock used is stiff it will be necessary to make the punch somewhat smaller than the finished size of the spring,

because the latter will open out somewhat when the pressure is removed.

When making looped wire work, a loop may be formed and the wire moved along against a stop, another loop formed, and so on, as indicated at *D*. When forming looped wire work it is customary to make the punch ball-shaped rather than cylindrical. The ball answers well on wire work and allows of the easy

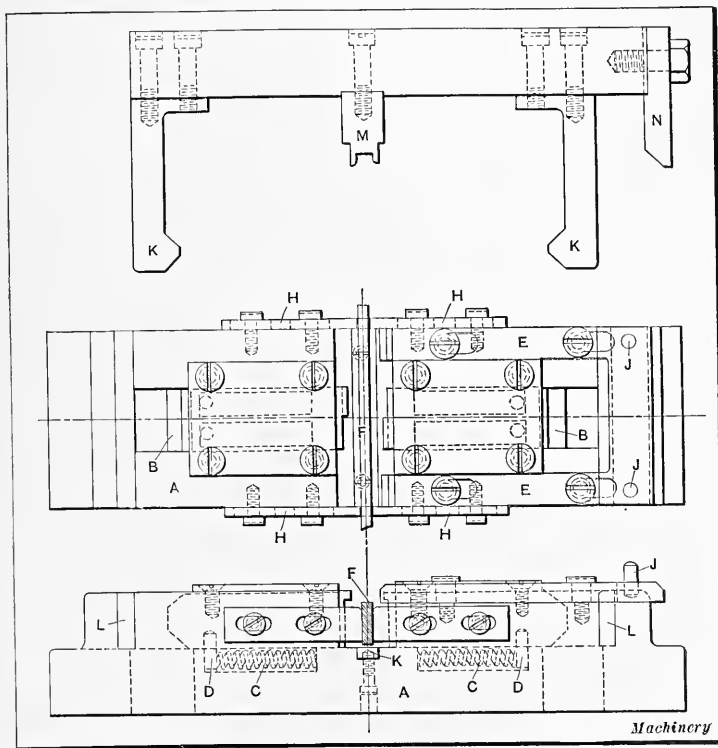

Fig. 2. Bending Die and Punch for Forming Piece shown in Fig. 3

removal of the loop. It is sometimes desirable to close the upper end of an article nearly together, and if the stock used is extremely stiff, such as that used for bow springs made from tool or spring steel, it may be necessary to heat the bow (which has previously been bent) red hot, and finish-bend it by a special operation. A great variety of work may be done by modifications of the methods for bending shown. Where but a few

pieces are to be bent it is not advisable to go to the expense of making costly bending dies, but when the work is done in large quantities, such dies will produce work uniform in shape at a low cost.

Blanking and bending dies are made which not only punch the article from the commercial sheet, but bend it to the desired shape in the same operation. As a rule, it is advisable to blank the article in one operation and bend it in another, but there are certain forms of work where it is possible to do it in a satisfactory manner in one operation and at a cost not exceeding that of the ordinary blanking operation. This also effects a saving in the cost of tools, as the special bending die is dis-

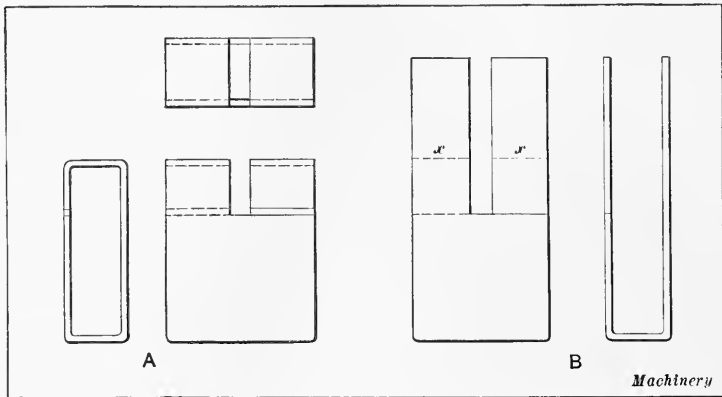

Fig. 3. Bending Operation Performed in Die shown in Fig. 2

pensed with. Diagram *F*, Fig. 1, represents a punch and die used in punching the shoe *k* to the proper shape shown, whereas sketch *G* illustrates a method of producing the spherical tension washer shown. Gun and other irregular shaped springs are often punched to form by dies of this type, although, when stock suitable for use in making springs is employed, it will be found necessary to make the face of the punch somewhat different in shape from that desired, as the piece will straighten out more or less after it is punched.

**Die for Making Four Bends.** — The die shown in Fig. 2 was designed and made for the third and last bending operation on the piece shown at *A* in Fig. 3. The metal is  $\frac{1}{16}$  inch thick, of



soft composition, and easy to bend. The first and second operations are performed in a like number of dies, the blanking or cutting from strip stock being done in one die, and the bending of the blank to a U-shape, as shown at *B*, in another. No description of these tools will be given here as they are of simple construction and readily understood by those who are at all familiar with die designing and die making.

The tool under consideration, shown in Fig. 2, has, of necessity, several movable parts in order to make the four bends required to complete the work. All the members are of simple outline and easy to make and assemble; therefore no detailed description of the methods of machining each part will be given. The holder *A* is of cast iron and is machined on the bottom, top, and sides to receive the several steel parts. The bending slides *B* and *B* are located in finished seats in the holder and secured in place by plates  $\frac{1}{4}$  inch thick, each of which is, in turn, fastened by four  $\frac{5}{16}$ -inch countersunk screws. The slides *B* have a close running fit, and are forced in, to make the right and left bends, by the cams *K* on the punch; their opposite or outward movements are made to take place by four compression springs *C*, located in the holder and acting against the pins *D* which are tightly driven into slides *B*. The third slide *E*, which has slotted holes to allow it to move in and out a limited distance, begins to operate after the other two have done their work; the object of this latter slide is to hold the steel form *F*, upon which the work is mounted, down, and free the formed piece from the punch on the up-stroke. Springs hooked to the right-hand end of the press bolster and to pins *J* return the slide *E* when the ram ascends. The four steel pieces *H* are adjusted, when the die is first set up in the press, to properly locate the form *F* which holds the work. The hardened rectangular steel piece *K* forms a seat for the work. Hardened steel pieces *L* and *L* support the punch parts *K* and prevent their spreading when acting on the bending slides *B*.

The work, having been bent U-shape previous to the finishing operation, is put on the former *F* which it pinches sufficiently to hold its own weight, and is carried to the die. On the down-

stroke the punch parts engage the inclined faces of the bending slides *E* and force them in, causing the right and left horizontal bends to be made at points indicated by the dotted lines *x* in Fig. 3. Further downward movement of the press ram permits these two slides to move out. The cam *N* forces the slide *E* inward until the inner ends extend over the bending form *F*, holding it down until the final bends are made by the former *M*, and the punch ascends sufficiently to free itself of the work. As the press slide continues to go up, the bending slides *B* make another in-and-out movement, thereby striking the formed piece a second time and setting the bends. The finished part is removed from the form by dropping the latter into a yoke

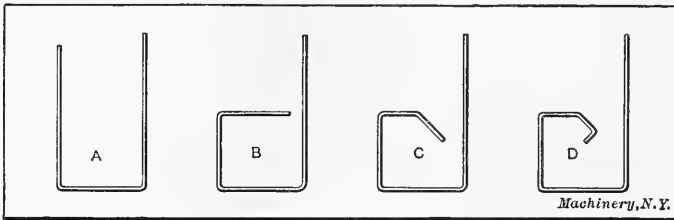

Fig. 4. Successive Bending Operations Effected by Die shown in Fig. 5

secured to the press in a convenient position, and giving a slight pull, thus stripping the work. It has been found advisable to taper the forms slightly from the section where the work is located, to the rear, to facilitate the removal of any material, after it is bent, that has a tendency to hug and not spring away. A suitable handle should be on the front end of the form, for the comfort and convenience of the press-man, and it should extend to the front of the die sufficiently to make it absolutely unnecessary for the operator to incur any danger of accident by putting his hands between the working parts of the tool. The press in which this type of die is used is usually run at about 100 strokes per minute, and has a slide movement of three or four inches.

**Die for Making Five Bends.** — The making of the five bends in the piece shown at *D* in Fig. 4 was thought at one time to require a very expensive punch and die. Upon laying it out, it was found, however, that while there were a large number of

parts required and various movements to be provided for, the punch and die would not be at all complicated; and would come within the limit of cost that was allowed for this operation. The stock from which this piece *D* was to be made was one-quarter hard brass,  $\frac{1}{2}$  inch wide and about 0.023 inch thick. The stock was received in strips of the correct width, and, previous to bending, it was cut to required length. After the pieces were cut to the required length, holes were drilled and

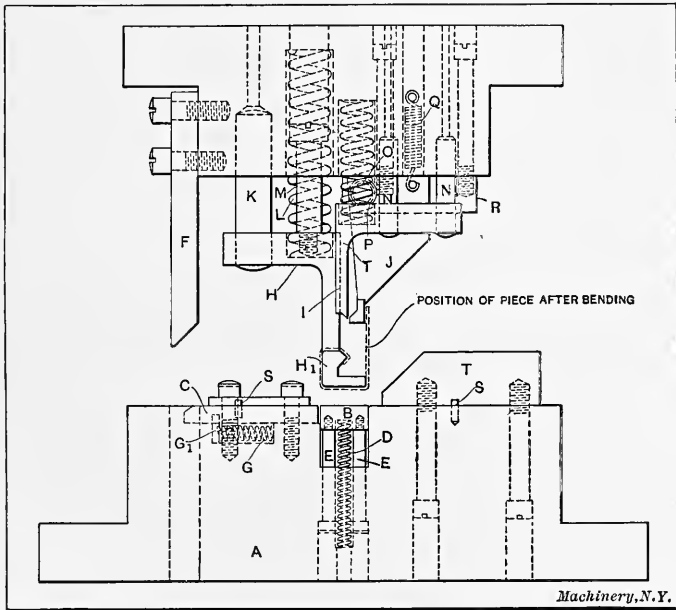

Fig. 5. Punch and Die for Making and Bending the Part Illustrated in Fig. 4

countersunk for wood-screws. As the positions of these holes were not always the same, it was decided to drill them instead of piercing them, while cutting the blanks off.

A front elevation of the piece and the punch and die used for completing the bends in the piece shown at *D* is shown in Fig. 5. This punch and die was provided with two 1-inch guide-posts for retaining the alignment. These guide-posts are not shown in the illustration, but were located at the rear of the moving parts, so as to be out of the way of the operator. In designing this

punch and die the usual plan of bringing all the working parts to the front was observed. This facilitates the operating of the die and obviates the chance of the operator putting his hand in a dangerous position. Referring to the illustration, Fig. 5, *A* is the cast-iron body of the die, which is machined to receive the spring pad *B* and the bending slide *C*. The pad *B*, as shown, is actuated by a coil spring *D*, and is retained in its upward position by the two fillister-head screws *E*. This spring *D* should be weak enough, so that it will be easily compressed by the punch when descending into the die. The slide *C* for making the third bend is advanced by the cam *F*, fastened to the punch-holder as shown, and is retained in its backward position by a coil spring *G*, which bears against a pin *G*<sub>1</sub>, located in the base of the slide.

Attached to the punch-holder is the punch *H* which forms the first two bends to the blank; the third bend is accomplished by the slide *C* in the die; the fourth bend is made by the punch *I*, and the fifth bend by the punch *J*. The punch *H* slides on two dowels or guide pins *K* (one of which is shown) and works against a coil spring *L*. Two fillister-head screws *M* (one of which is shown) limit the position of this punch. The forming punch *I* slides on two dowels or guide-posts *N* and is operated by a coil spring *O*. The downward movement of this punch is limited by two fillister-head screws, not shown. The swinging punch *J* rotates on a stud *P*, and is retained by a closed spring *Q*. This punch *J* is fastened by the stud *P* to the block *R*, which, in turn, is held to the punch-holder by two fillister-head screws, as shown.

In operation, the strip is placed between the locating pins *S* and also between other locating pins not shown, which hold the blank in the correct position. Then as the ram descends, the punch *H* forces the blank down into the die on top of the pad *B*. This forms the blank into the shape shown at *A* in Fig. 4. On further movement of the ram, the cam *F* comes in contact with the slide *C* forcing it in and bending the blank over the projected part *H*<sub>1</sub> of the punch *H*. This forms the blank to the shape shown at *B*. As the ram descends still

further, the punch *I* bends the blank around the punch *H*<sub>1</sub>, giving it the shape shown at *C*. The fifth bend is made by the punch *J*, and is accomplished as follows: As the ram still continues in its downward movement, the punch *J* comes in contact with the block *T*, fastened to the die-block as shown. This block *T* rotates the punch *J* on the stud *P*, and forces the blank around the punch *H*<sub>1</sub>. On the up-stroke of the punch-holder, all the slides and punches are returned to their normal position, the projection *H*<sub>1</sub> on the punch *H* carrying the blank out of the die and leaving it in the position shown by the dotted lines

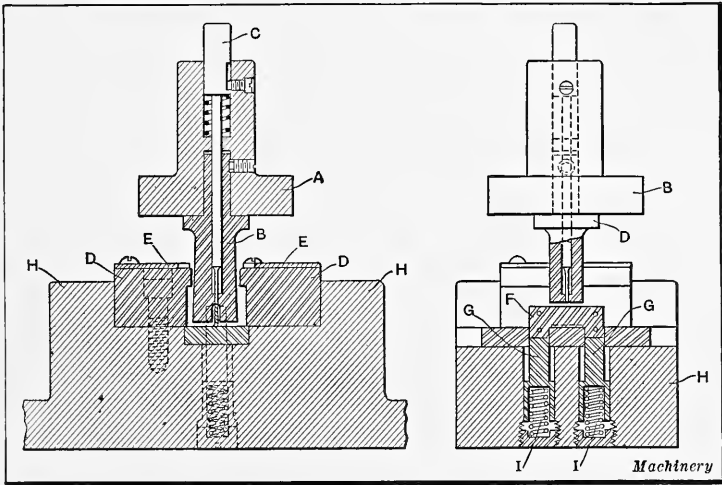

Fig. 6. Sectional Views of Staple Bending Die

(Fig. 5), when it is removed by hand. The forming part of the punch *J* is offset from the main body of the punch, as can be seen, so that the blank will slide up past it. The forming part *H*<sub>1</sub> of the punch *H* is also offset, thus allowing the blank to be bent around it.

All the springs in a punch and die of this description should be of the best quality and well tempered, so that they will not become fatigued to such an extent as to render any part of the mechanism inefficient to even a slight degree.

**Staple Bending Die.** — The die shown in Fig. 6 was designed for bending a large number of staples that were to be made of

0.025-inch sheet steel. The cast-iron punch-holder *A* carries the tool-steel punch *B*, which has ejector bar *C* running through its center. The outside bending dies *D* are provided with nests *E* for locating the blank in the required position preparatory to

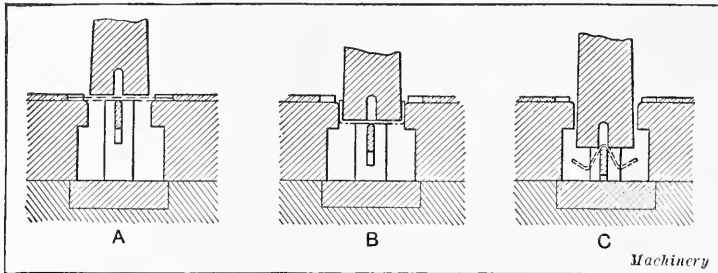

Fig. 7. Successive Stages in Bending Staple in Die Illustrated in Fig. 6

bending. The staples are bent over the inside former *F*, which is riveted to the tool-steel pins *G*, the pins *G* being a sliding fit in the die-shoe *H*.

The detail views *A*, *B*, and *C*, Fig. 7, illustrate steps in the downward stroke of the punch. At *A* the blank is shown in

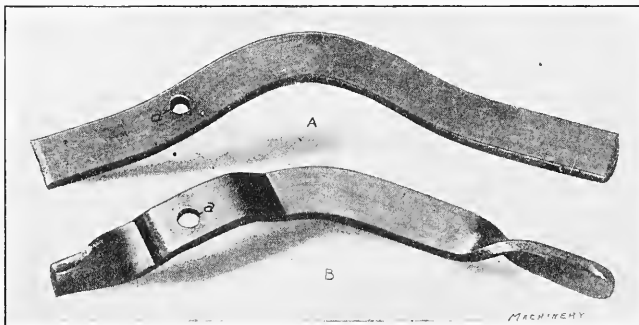

Fig. 8. Steel Latch which is Bent and Twisted in Die shown in Fig. 9

position in the nest ready for the punch to descend upon it. Sketch *B* shows the punch after it has carried the blank down between the side bending dies and brought it into contact with the inside former, and at *C* the punch has descended a little further, with the result that the blank is partially bent over the former. At the conclusion of the downward stroke, the two sides of the staple will be bent into close contact with the former. This is the position shown in Fig. 6.

On the upward stroke of the punch the inside former *F* rises with the punch until it is flush with the top surface of the die, this movement being actuated by the springs *I* that act against the lower side of the pins *G* on which the former *F* is mounted.

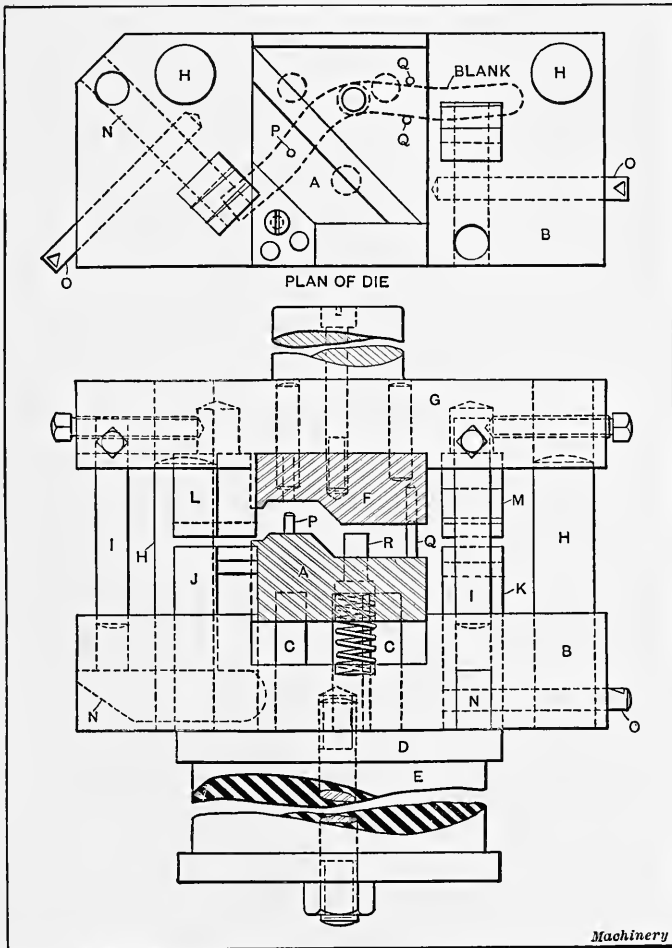

Fig. 9. Elevation and Plan of Combination Bending and Twisting Die

The staple is held in the punch *B* until the punch has almost reached the top of its stroke. At this point a knockout bar on the punch press strikes the ejector bar *C* and ejects the staple from the punch. The press is inclined so that the work

drops clear of the die and leaves the latter ready for the next operation.

**Combination Bending and Twisting Die.** — A latch for a go-cart is shown in Fig. 8, which was formed and twisted in the die shown in Fig. 9. This latch is first cut off and formed to the shape shown at *A*, Fig. 8, after which it is placed in the die and is bent and twisted to the required shape shown at *B*. The lower bending die *A*, Fig. 9, is held in a cast-iron base *B*, and pins *C*, driven into the former, extend down through the base and come in contact with a pressure plate *D* operated by a rubber pad *E*. The top forming die *F* is held by screws and

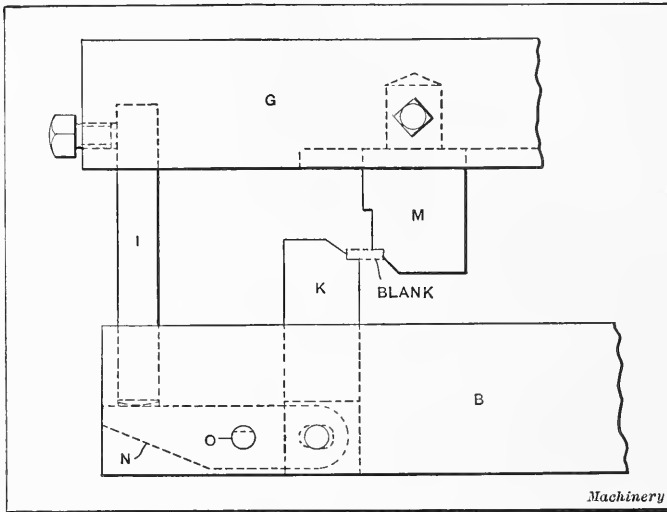

Fig. 10. Detailed View showing how Twisting Dies *K* and *M*, Fig. 9, are Operated

dowels, as shown, to the holder *G*, which has a shank to fit the hole in the ram of the press. This holder *G* is lined up with the base *B* by standards *H*, and holds two pins *I* which operate the lower twisting dies *J* and *K*. The twisting dies *J* and *K* correspond in shape to the dies *L* and *M*, which are provided with shanks and are held in the holder *G* by screws and dowels.

The lower twisting dies *J* and *K* are given a slight upward movement by means of the pins *I*, which come in contact on



the downward stroke of the ram with fulcrumed levers *N* held on pins *O*. These fulcrumed levers are connected to the twisting dies by pins, as shown more clearly in Fig. 10, where the operation of the twisting dies *K* and *M* is illustrated.

In operation, the blank shown at *A* in Fig. 8 is placed on the lower die *A*, the hole *a* fitting on the pin *P* and the blank being located between the pins *Q*. A spring plunger *R*, operated as shown in Fig. 9, prevents the blank from dropping down, holding it flush with the highest surface of the lower forming die. As the ram of the press descends, the upper former forces the blank down, bending it to the shape shown at *B* in Fig. 8, and as the ram still continues in its downward movement, the pins *I* operate the lower twisting dies through the levers *N*. The combined action of the upper and lower twisting dies forms both ends of the blank to the shape shown at *B* in Fig. 8. The lower die *A*, while the twisting operation is taking place, has been forced down to the lowest point of its travel, compressing the rubber pad *E*, which returns it to its former position when the ram of the press ascends.

**Compound Bending Die.** — In Fig. 11 are shown end and side elevations of a die for making the two bends in the piece shown at *B*, Fig. 12, the shape of the blank previous to bending being shown at *A*. The die-bolster *A* is bored out to receive the two guide-rods *B*, which are made a sliding fit in the die-holder *A*. It will be noticed that the bosses on the die-holder *A* are made large, sufficient material having been left so that they could be bored for bushings. However, in this case it was not thought necessary to use bushings, inasmuch as the die was not intended for continuous operation. The stud or cam *D* held in the punch-holder presses on a block *E*, which, in turn, operates the bending-die holder *F*. A hardened block *G*, of the same size as *E*, is held by a screw *H* in the die-bolster to take the thrust of the stud *D*. The stud *D* is made with a 45-degree angle. All of these parts are made of machine steel and casehardened. The movable member *F*, or die-holder, carries the die *I*, which, after the bending operations are completed, is returned to its normal position by the spring *J*, held in the bolster.

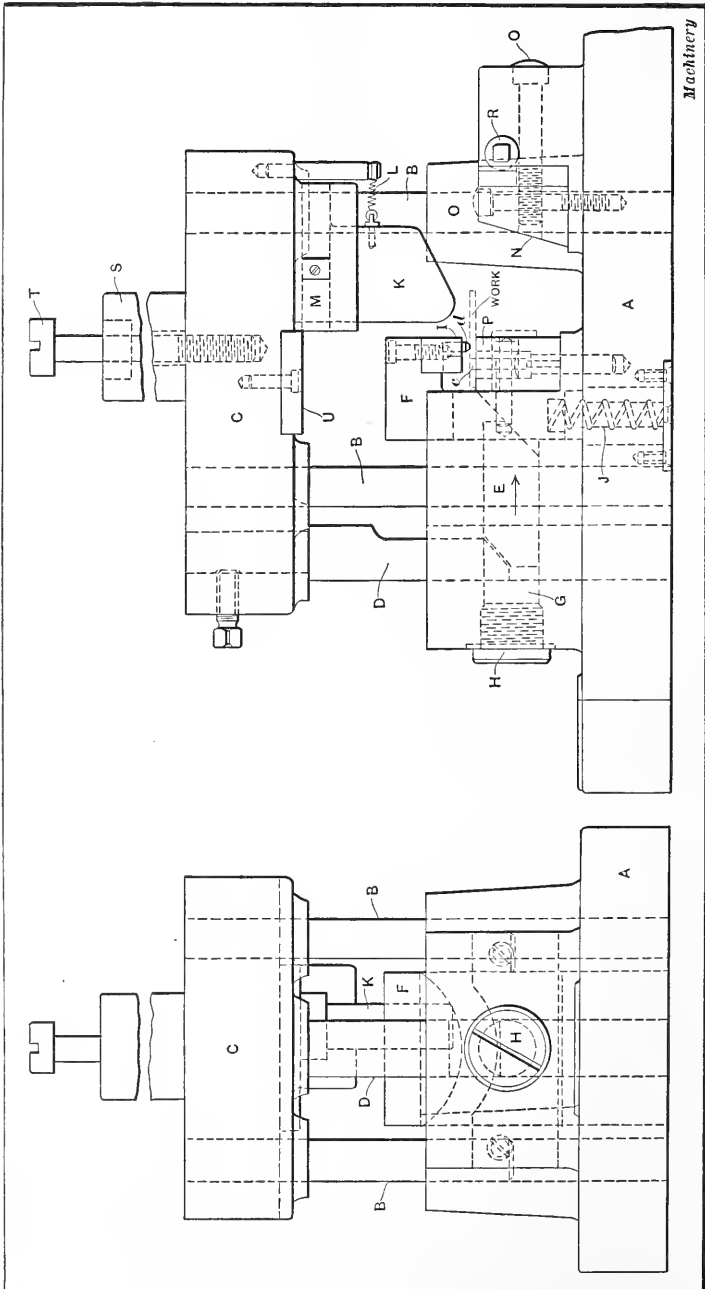

Fig. 11. Compound Bending Die for Bending the Flat Blank a, Fig. 12

The bend *a*, Fig. 12, is performed with the die *I*, while the bend *b* is made with the punch *K*, which is held to the upper member. This punch *K* slides in a slot cut in the upper member, and is retained by a spring *L* against the stop *M*, when in its normal position. In operation, the piece to be bent is located in the lower die *P* in the position shown at *B* in Fig. 12, being placed against two pins *c*, held in the lower die. The blank is also additionally supported when the dies come together, by a pin *d* held in the die *I*. This pin is so shaped that it fits the slot and locates the blank properly. When the blank is located in the die *P*, the punch-holder descends, and the die *I* makes the circular bend *a*, which is accomplished by the stud *D* forcing the block *E* in the direction indicated, thus drawing down the

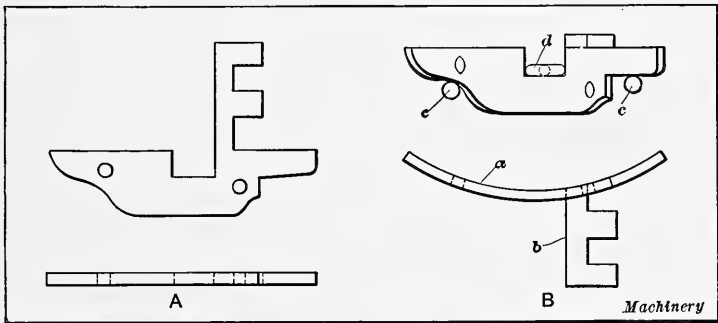

Fig. 12. Blank Before and After Bending Operation

member *F*, holding the bending die *I*. When the stud *D* has descended  $\frac{7}{16}$  inch, the holder *F* comes to rest, so that the blank is held firmly when the punch *K* acts on it for making the right-angle bend. The punch *K* then comes in contact with the blank and the adjustable block *N*. The block *N* is tapered as shown, and deflects the punch *K* inward, so that it slides in the punch-holder, and in its descent bends the blank at right angles. The block *N* is held to the die-bolster *A* by means of three screws *O*, and is adjusted inward by a tapered gib operated on by a screw *R*. Having the block *N* adjustable in this manner makes provision for the blank to be bent to such shape that after the punch retreats it will spring back to the angle desired. The shank *S* is held to the punch-holder *C* by a screw *T*. A hardened

block *U* held to the punch-holder *C* comes in contact with the holder *F*, and gives the final blow to the blank.

**Curling Dies for Hinges.** — The dies used for making hinges are about as numerous in design and vary as much as the hinges themselves. They range from small punches and dies for blanking and curling in separate operations, to the complicated automatic machines and press attachments for producing the

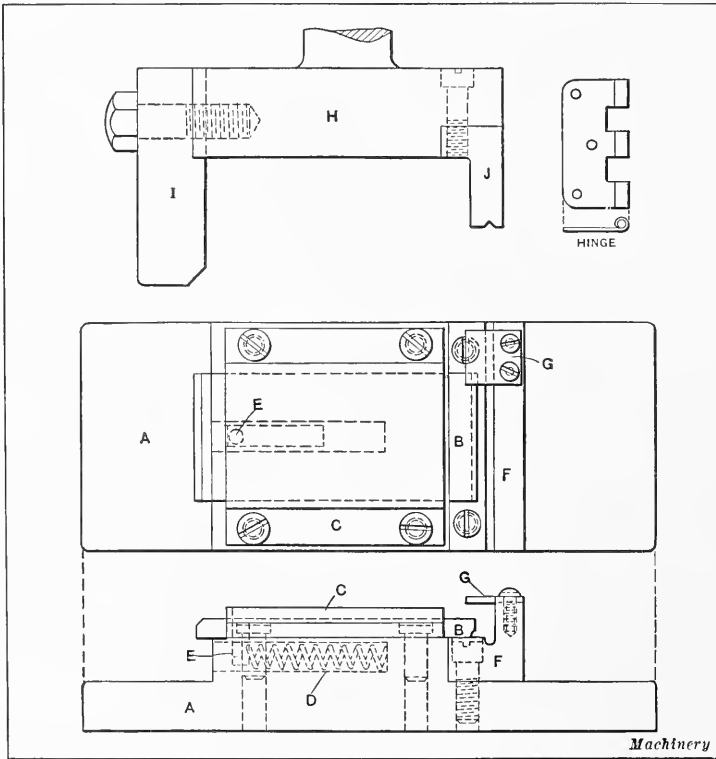

Fig. 13. Punch and Die for Curling a Hinge

hinge complete with the two parts and pin assembled. The exact design of the die for making a hinge or, in fact, any other difficult piece of work cannot, of course, be determined arbitrarily but must be governed by conditions. In any case, a die should be so designed that its first cost is not out of proportion to the amount saved by its use. The two dies shown in Figs. 13

and 14 are for curling both parts of the same style of hinge and are simply two differently designed tools for doing the same kind of work. This hinge is shown in the upper right-hand corner of Fig. 13. The ratio of production between the two dies was about 5 to 7 in favor of the die shown in Fig. 14. This difference in output was noted while they were being used at different times in the same press and by the same operator, the

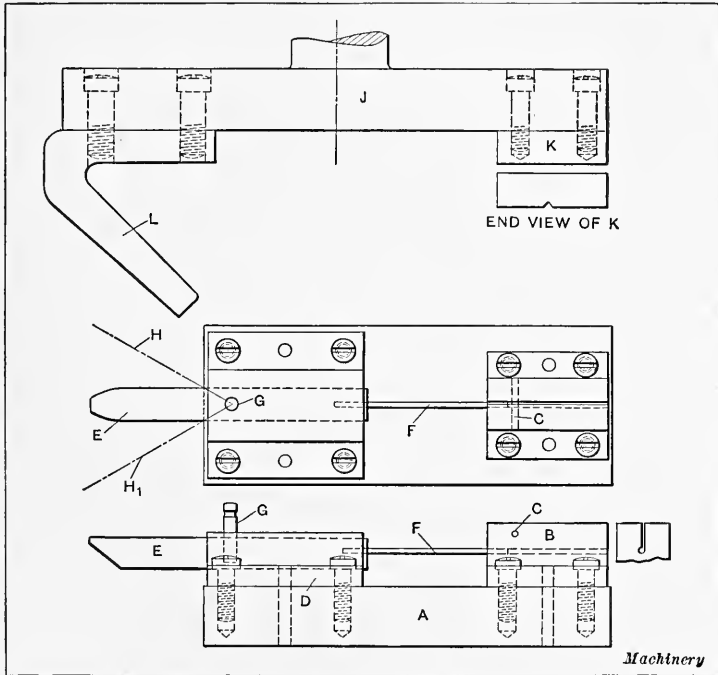

Fig. 14. Hinged Curling Die with Automatic Ejector

press being run at as high a speed as is consistent with good practice.

The die shown in Fig. 13 consists of a holder or body *A* of cast iron; a slide *B* of tool steel (hardened, and finished by grinding); a cast-iron cap *C* secured to the body *A* by four screws and holding in place slide *B*, permitting it to have a free lateral movement; a spiral spring *D* for moving the slide outward on the upward stroke of the press, by pressure against pin *E*; a tool-steel die *F* which curls the blank, thus forming the hinge

joint; and a gage *G* for locating blanks and preventing the operator from pushing them too far back into the die. The punch consists of a holder *H*, a punch *J*, and a cam *I*. The working face of this cam is polished and made as hard as possible; it engages the angular end of slide *B*. The punch *J* has a small V-shaped groove planed in its lower face and engages the upper edge of the hinge blanks. When the die is in operation, the blank is placed between the inner end of slide *B* and the die *F*. When the punch descends, it forces the slide firmly but lightly against the side of the blank and the continued downward movement causes the lower edge to curl around in the circular pocket formed by the parts *B* and *F*. On the upward stroke, the slide *B* is pulled out to the limit of its movement by spring *D*, thus permitting the finished hinge to be removed and a new blank inserted.

The second die, illustrated in Fig. 14, has a cast-iron base *A* to which die *B* is attached. At the rear of die *B* there is a bracket *D* in which the sliding shaft *E* is mounted. Inserted in the forward end of this shaft is a piece of drill rod *F*, the outer end of which is hardened and fits into the hole in the die *B*. Driven into shaft *E* is a spring post *G* to which are hooked two closely coiled springs, their opposite ends being fastened to pins located in the bolster in such a position as to hold the springs at about the angle indicated by the dotted lines *H* and *H*<sub>1</sub>. On the downward stroke of the punch, these springs hold shaft *E* in the position shown in the illustration. The object of the angular arrangement of the springs is two-fold: In the first place, it avoids interference between the springs and cam *L* on the punch, and, second, it minimizes the possibility of an accident. For instance, if one spring should break, the other would do the work. The hinge blank is located in die *B* by stop-pin *C* which extends across the slot in the die. When the punch and die are set up in the press, it will be understood that cam *L* is below shaft *E*. When the punch descends, rod *F* is withdrawn by the springs in time to clear the blank before it is forced down and curled. On the return stroke, the shaft is positively advanced by contact with cam *L*, thus forcing it

forward and ejecting the hinge from the die. This tool had to be operated in a press having the right length of stroke, to prevent the cam *L* from raising entirely clear of the end of shaft *E*. The ejecting device permitted a continuous feeding of the blanks to the die, thus increasing the output, as previously mentioned.

Although these dies are simple in design, there are several points which should be observed when constructing them. To insure accurate and uniform production, the parts which curl

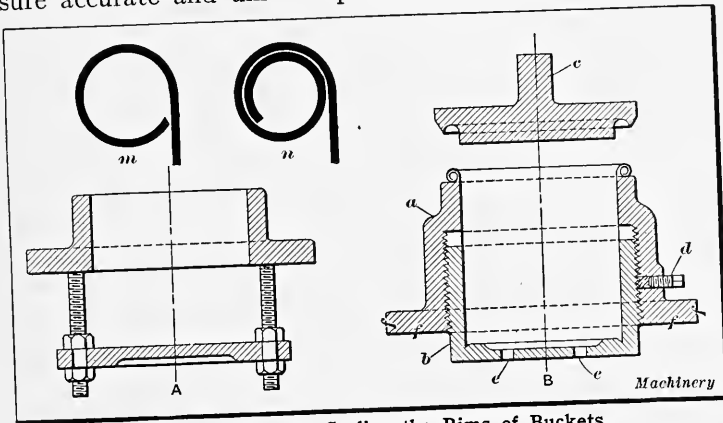

Fig. 15. Dies for Curling the Rims of Buckets

the metal must be accurately made and smoothly finished. The curved surfaces should also be as hard as possible because there is considerable wear at this point, owing to the friction of the curling operation. When setting the die, it should be carefully aligned with a punch so that when the V-groove on the lower side of the punch engages the upper edge of the blank, the latter will be held in line with the slot in the die, as otherwise the blank will have a tendency to buckle. The stroke of the press should be carefully adjusted so that the punch descends just far enough to complete the curl, and no more. If it descends too far, the work will jam the die so that it cannot readily be removed. It is also essential that a lubricant be used on the blanks to eliminate unnecessary friction in the curling operation. When using a die of the type shown in Fig. 14, it is important to use blanks that have no burrs on them,

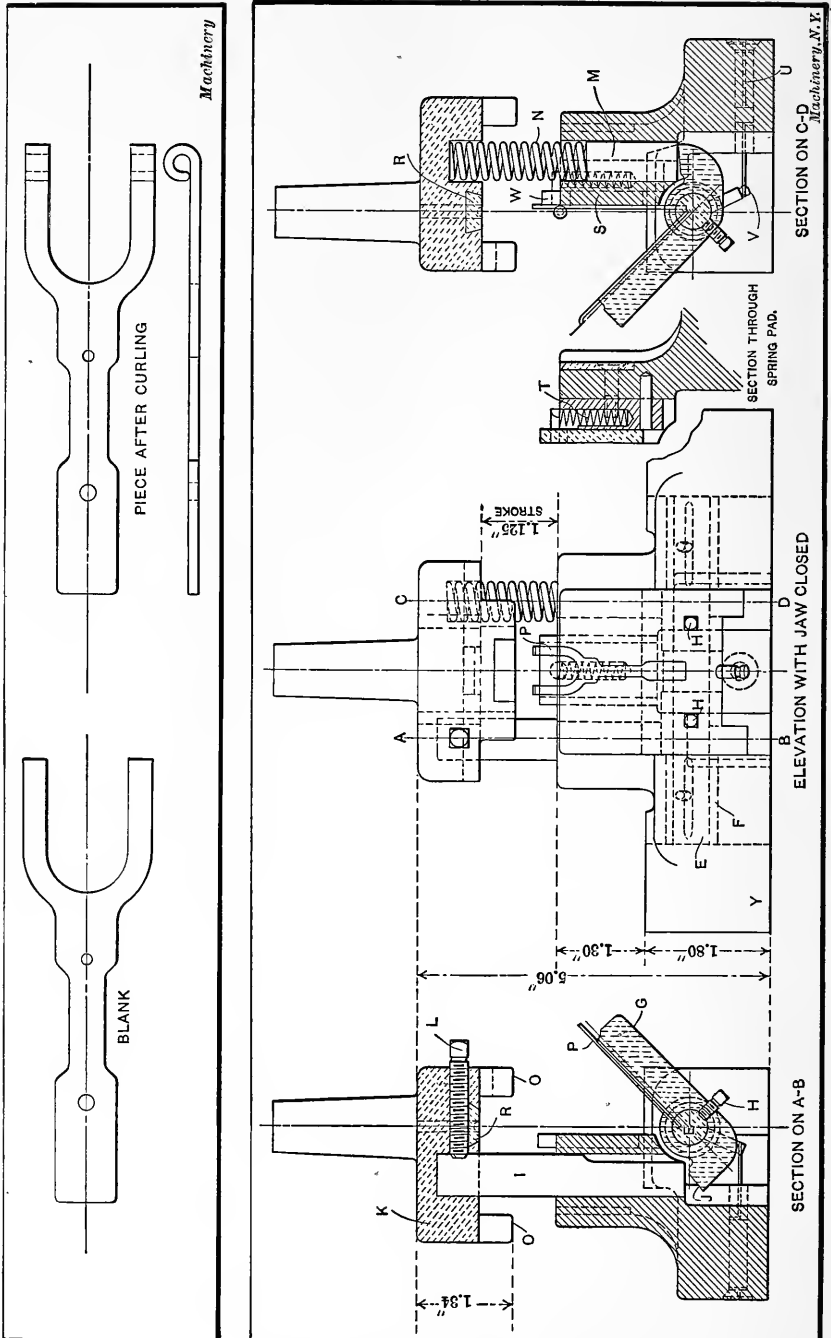

Fig. 16. Curling Die for Typewriter Part shown in Upper Illustration



because the opening in the die to receive the blank should be only about 0.003 inch wider than the thickness of the stock.

**Curling Dies for Tin Buckets.** — In Fig. 15 are shown two adjustable curling dies, such as are used for the curling, or “false wiring,” of straight tin buckets. Dies of this style can be used for curling the rims of buckets of various depths, by adjusting the bottom of the die to the depth of the bucket to be curled. The die shown at *A* is an old design, and it was somewhat difficult to properly adjust the bottom of this die, as one side was very apt to be a little higher than the other, which caused trouble. Because of this trouble in connection with the adjustment, a new die was made, as shown at *B*. The cast iron body *a* was faced off as indicated by the finishing marks *f*, and a thread cut on the inside as shown. The part *b* was then threaded to fit *a*, and these two parts were screwed together. They were then clamped to the faceplate of a lathe, and set by the finished surfaces *f* of *a*. The hole on the inside was then bored, and it was given  $\frac{1}{6}\frac{1}{4}$  inch taper, so that the body of the bucket would enter with ease. The punch *c* was also made of cast iron, and finished so that it would give the desired diameter of curl.

This die is operated in a wiring press, which has a sliding table. The bottom part *b* is screwed down to nearly the depth of the bucket body, just enough stock projecting above the die to make the curl. The amount of stock required for the curl can easily be found by trial. When the part *b* is adjusted (which is done by inserting a suitable wrench in the holes *e*), it is held in place by the set-screw *d*, which forces a threaded brass plug against it. At first this die was used for curling the tin over wire, but subsequently for double-curling, as shown at *B*. To do this, it is first necessary to make a single curl, as shown at *m*, then screw the part *b* in about  $\frac{1}{4}$  inch, and repeat the curling operation, thus obtaining a double curl as at *n*. Much time is saved by curling buckets in this way, and they are almost as strong as when wire is used.

**Curling Die for Typewriter Part.** — The punch and die illustrated in Fig. 16 completely forms the curl in the forked lever shown in the upper illustration and also in position in the die

at *P*. This piece is known as the "ribbon reverse weighted lever" of the Remington typewriter. It is the usual practice in most cases to form the curl of such a piece in two or three operations. The first operation usually starts the bend, and the curl is finished in the second or third operation by being formed around an arbor. However, in the present case the eye is completely formed in one stroke of the press in a vertical acting punch and die.

To the base *F* of the die are attached the other working parts, the principal one being the clamp or jaw *G*. This jaw is provided with a nest for holding the piece to be operated upon. It rocks on the shaft *E*, the ends of which turn in hardened and ground bushings *B*, which are provided to protect the base from excessive wear. The bushings are provided with oil holes as indicated. The jaw is not fitted tightly to the shaft, that is, the shaft is not a drive fit in the jaw, but is fastened to it by two small set screws *H*. This feature allows the jaw to be adjusted at exactly the correct angle, and also permits of easy and quick dismounting in case of repairs.

When the press starts its downward movement, the pin *I* bears against the lug *J* on one end of the jaw *G*, causing the latter to swing up into a vertical position. The pin *I* is secured in the tool-steel plunger *K* by the set screw *L*. At the opposite side of the plunger, and bearing against an opposite lug of the jaw *G* is a short plunger *M* actuated by spring *N*. This plunger is provided for equalizing the pressure on *G* and for preventing excessive torsional or twisting strain.

A further downward movement of the ram causes the ears *O* on the plunger to engage and bear against the front or outside of the jaw and the rear of the base, thus holding the jaw securely in the upright position and preventing it from springing back. A hardened and ground bearing plate of tool steel is provided in the rear of the base, where it engages lug *O*, to prevent excessive wear. The grooved former *R* next comes in contact with the top of the work and starts the curl, which is finished at the end of the stroke. The supporting pad *W* is depressed in the meantime, sliding in the block *S*. On the up stroke of the press the

pad is returned to its normal position by the spring shown at *V*. The jaw is released by the raising of the pin *I* and falls back by gravity into the position shown to the left. It is aided in falling back by the spring *U*, secured to the back of the base and to the stud *V* at the bottom of the jaw.

**Wiring Dies for Small Brass Covers.**— Three forms of wiring dies are shown in Fig. 17. These were designed for curling the edges of brass covers, but on account of the smallness of the wire in proportion to the thickness of the metal, considerable trouble was experienced before securing a die that would do the work properly. The brass was 0.013 inch thick, and the wiring was 0.075 inch in diameter. The covers were first drawn to the right shape and length in single action combination dies. Then

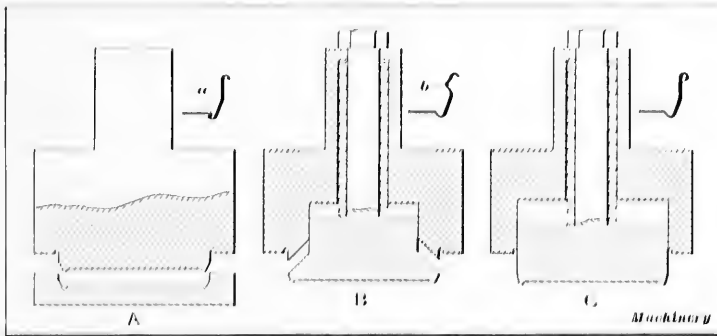

Fig. 17. Three Forms of Wiring Dies

a wiring die of the design illustrated at *A* was made, but it was not a success, as the covers appeared as shown in the enlarged section. The metal, instead of wiring at the top, curled back at the point *a*, forming an inner shoulder. To overcome this difficulty, the punch was bored out, as shown at *B*, and a spring pressure pad inserted to prevent the bottom buckling. While this undesirable feature was eliminated, buckling occurred in the side at the unprotected section, between the pad and the punch, as shown at *b* in the enlarged section. This, however, gave a clue to the proper solution of the problem, which was to bore out the body of the punch still larger and insert a pressure pad equal in size to the full diameter of the inside of the cover, as shown by the right hand view *C*.

## CHAPTER V

### CONSTRUCTION AND USE OF SUB-PRESS DIES

The sub-press die was originated in watch and clock factories for performing blanking operations requiring great accuracy, and, at the present time, dies built on the sub-press principle are employed for a great variety of work and in connection with many different lines of manufacturing. The sub-press is invaluable not only for blanking the delicate wheels and gears of watch and clock movements, but for producing the numerous small parts, such as are required for time-recorders, electrical instruments, meters, cyclometers, and a great many other similar devices. In fact, the extensive use of parts stamped or cut from sheet metal, in many delicate forms of mechanism, has been made possible by the sub-press, owing to the accuracy which can be obtained; moreover, the rapidity with which the parts can be produced has resulted in a great reduction in the cost of manufacture. As explained in Chapter I, the sub-press is not a type of die but rather a method of constructing dies so that the upper and lower members are combined in one self-contained unit and held in accurate alignment. The fact that the sub-press is a self-contained tool and is not dependent upon the power press in which it is used (except for motion), combined with the ease with which a sub-press can be arranged for use, means not only accuracy but a great saving in time, because in setting up the sub-press it is simply necessary to slide the head of the punch plunger into a T-slot of the press slide, clamp the base to the bed of the press, and adjust the stroke. The sub-press is not only a time-saver but possesses another distinct advantage in that the unit construction makes it unnecessary to align the upper and lower die members. Still another point in favor of the sub-press is that this construction makes it possible to pierce smaller holes in thick stock than is possible with

other dies, because the small punches are supported along almost the entire length. It is not unusual to punch holes in stock having a thickness which is over twice the diameter of the pierced hole. With sub-press dies a narrower "bridge" can also be left between blanks and a much better blank obtained than with any other form of die. The blanks are not only free from burrs, but always of a uniform size, the die being straight instead of having clearance, as in the case of an ordinary die through which the blanks must pass; therefore, the first blanks punched from a new sub-press die are practically exact duplicates of those obtained when the die is about worn out; obviously, this means that a large quantity of work can be done in a sub-press die before it is unfit for use.

Owing to the large number of parts of which most sub-press dies are composed, the first cost is, of necessity, much higher than that of ordinary dies, but when we consider that the sub-press die, if properly made, will run ten hours per day for weeks at a time, without grinding, the initial cost does not seem so important. When using an ordinary follow die, it is almost impossible to obtain two blanks that are duplicates within very close limits of accuracy. One reason is that the stock to be punched is more or less wrinkled and does not lie flat on the face of the die; the result is that after the piercing punches have perforated the wrinkled stock and it is then flattened out, there is a slight variation in the distance between the holes. Moreover, the pilot-pins on the blanking punch, that are depended upon to locate the stock, cannot do this with extreme accuracy, since they are made a little smaller than the piercing punches to provide clearance. On many classes of work, follow dies are entirely satisfactory, but when the parts to be produced are small and delicate, and especially when great accuracy is necessary, a die of the sub-press type should be used.

**Typical Sub-press Die Construction.** — A brief description of a sub-press die for producing the blank shown at *A*, in Fig. 1, follows: The upper half of the casting or cylinder *B* is shouldered onto the base *C*, to which it is attached by screws *D*; it is also doweled in position by the two pins *E*. The plunger *F* runs in

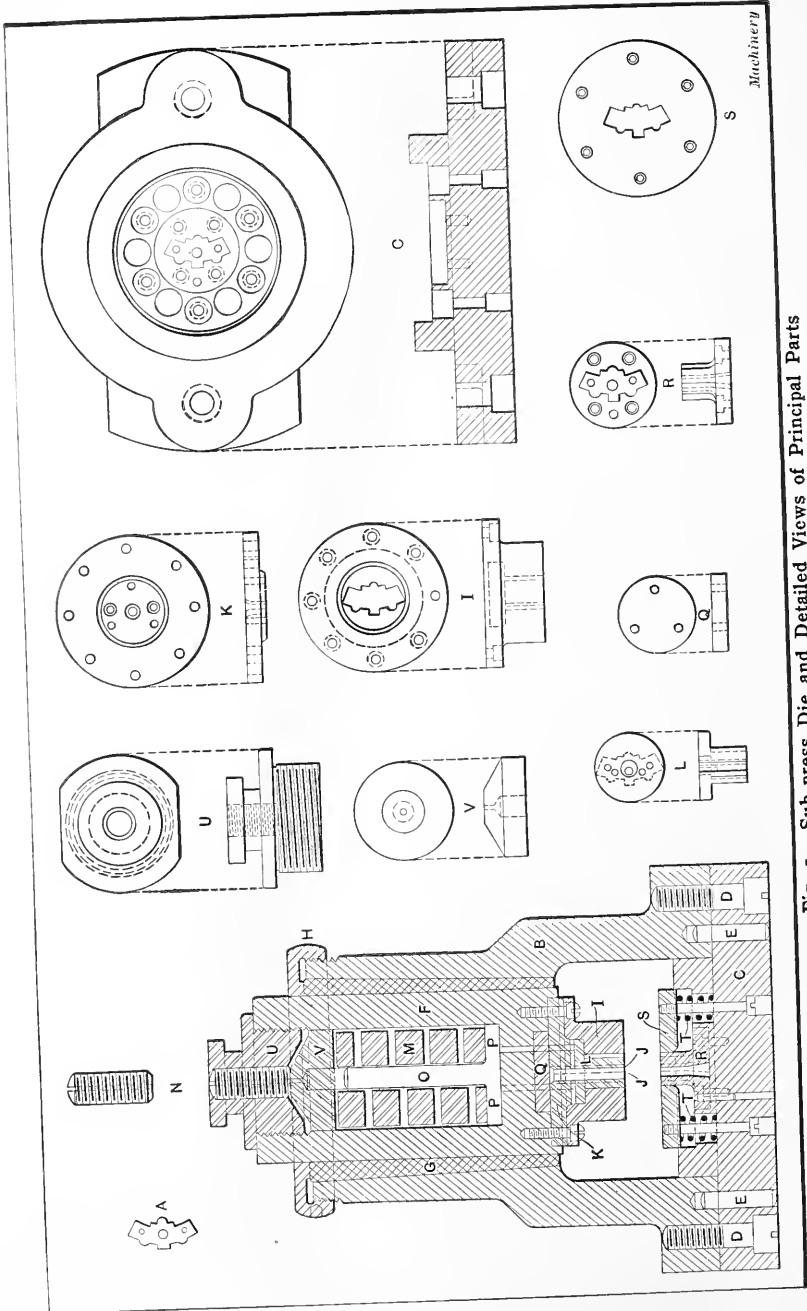

Fig. 1. Sub-press Die and Detailed Views of Principal Parts

a casing of babbitt shown at *G*, the wear in which is taken up when necessary by screwing down the tightening nut *H*, which forces the babbitt down and in at the same time, as the cylinder is bored on a slight taper. The plunger has three semi-circular grooves milled along its length to prevent its turning. Attached to the plunger is the die *I*, which cuts the outside of the blank, and the small punches *J* which are held in the back-plate *K* and supported by the shedder *L* which is backed up by the heavy spring *M*. The tension on this spring is obtained by screwing down screw *N* which has a small hole running through it to allow the air to escape. The center piece *O* and the three pins *P*, placed between the spring and shedder, supply the tension necessary to operate the latter. The hardened disk *Q* is pressed into the plunger behind the back-plate, as indicated, to take the thrust of the small punches. The base *C* is recessed to receive the base of the larger punch *R* which has three openings for the three small punches *J*, clearance being provided to allow the scrap punchings to pass through. The stripper in the lower member is shown at *S*, the resistance from the springs *T* doing the work. The most important parts are also shown in detail and are marked with corresponding reference letters.

In operation the plunger descends with the ram of the press and the stock caught between the two flat surfaces is held firmly in position, thereby preventing any creeping or distortion of the metal during blanking. The outside of the blank and the pierced holes are cut simultaneously, the die being a compound type. Upon the return stroke of the ram, the tension from the small springs *T* forces the stripper *S* back over the punch *R* which still has the blank pressed firmly against its face by the shedder *L*, forcing the blank back into the scrap from which it is afterwards removed.

Another sub-press of the common cylindrical type is shown in Fig. 2. To the base *B* is screwed and doweled the cylinder *A* lined with babbitt, as shown at *C*, this lining being provided with ribs which engage corresponding grooves in plunger *D*, which works up and down within the babbitt lining under the action of the ram of the press in which it is used. Nut *U* fur-

nishes an adjustment for tightening the babbitt lining to take up all slack due to wear, as fast as it is developed. The die *K* is screwed and doweled to plunger *D*. Accurately fitting the opening in this die is the shedder *H*, which is normally forced downward with its face flush with the face of the die by the action of spring *M*, which acts through the piston *N* and pins *O*. A similar construction is used in the bottom member: *J* is the punch, screwed and doweled to the base; and *L* is the

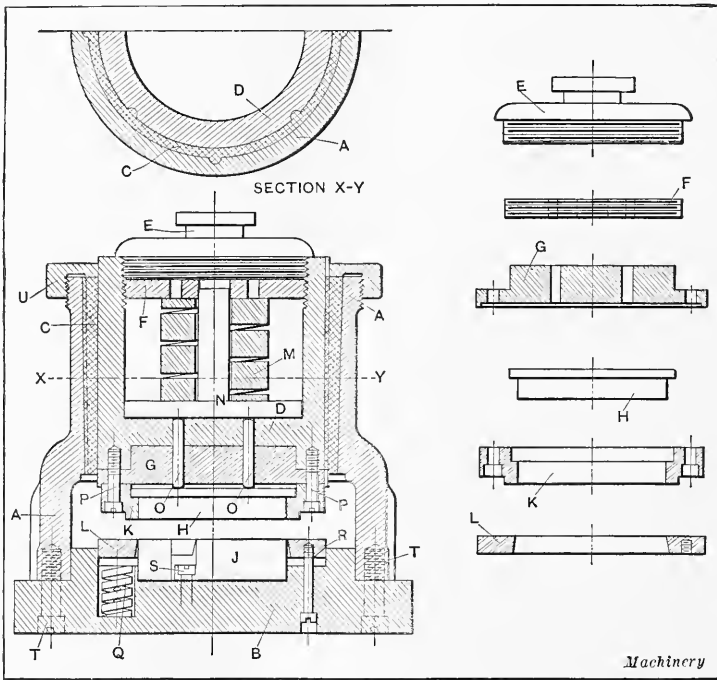

Fig. 2. Sub-press Die of Typical Design

stripper, surrounding the punch and accurately fitting it, and held firmly at the upper extremity of its movement by the pressure of suitable springs. This is restrained with its face flush with that of the punch, by the heads on stripper screws *R*. Thus it will be seen that the faces of the punch with its stripper and the die with its shedder may be ground off smooth and flush with each other, presenting to the eye the appearance of two solid plates of metal, the division between the



fixed and spring-supported members scarcely being visible if the fitting has been well done.

With this construction in mind, the enlarged details of the punch and die shown in Fig. 3 will be readily understood.

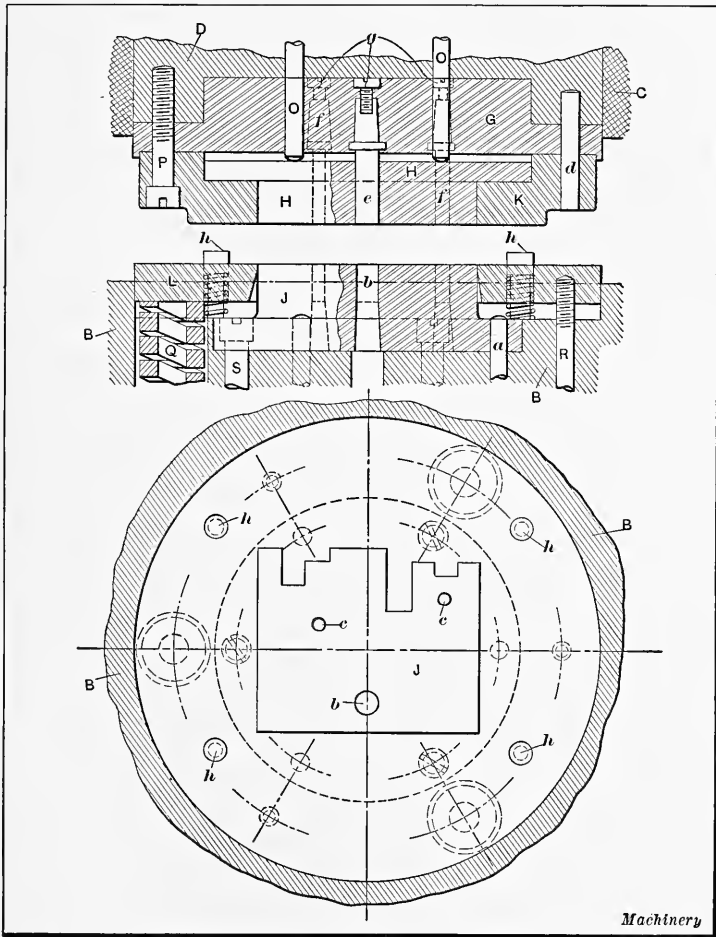

Fig. 3. Enlarged Views of Compound Die used in Sub-press shown in Fig. 2

Similar letters in each case refer to similar parts, but only the members of the device which actually work on the metal are shown. The outline of the punching made in this die is indicated by the outline of the punch and its stripper, as shown in

the plan view. There are two small holes  $c$  and one larger hole  $b$  in the blank. For punching these small holes, in addition to the simple arrangement shown in Fig. 2, openings in the punch are necessary, and small piercing punches have to be placed within the aperture of the die, passing through holes in the shedder; the holes in the punch are continued through the base of the sub-press, so that the waste material drops through beneath the machine. The piercing punches in the upper member are held to die pad  $G$  by holding screws  $g$  which draw these parts up into their tapered seats against the shoulders formed on them for the purpose. The fitting at all the cutting edges is done with great accuracy. The punch  $J$  fits die  $K$  very closely, and the shedder  $H$  is also closely fitted to the die. The stripper  $L$  is fitted to the punch, and small punches  $f$  are accurately aligned and closely sized to their corresponding openings in the face of main punch  $J$ . The pins  $h$  are used to guide the strip of stock, and are pressed down by the descent of die  $K$ , returning under the action of their springs as the ram ascends.

With the stock in place, die  $K$ , and with its small punches  $f$ , descends, the latter passing through the stock until they almost meet the corresponding cutting edges in the lower member. As soon as shedder  $H$  strikes the stock its motion is arrested, and it remains behind until the blank is cut, being meanwhile powerfully pressed upon the work by spring  $M$ . As the stock, while being sheared, is pressed down around the blank, it carries with it stripper  $L$  which also, by the influence of springs  $Q$ , exerts a heavy pressure on the stock. The whole area of metal being thus firmly held between plane surfaces, there is no danger of buckling or distortion of the stock as would otherwise be likely. As the ram moves upward again the blank is still firmly held on the stationary top of punch  $J$  by the shedder  $H$ . The stock, however, is carried upward with die  $K$  by stripper  $L$ , forcing the stock back over the punching again until the movement of the stripper is arrested by the heads of screws  $R$ , at the time when the face of the stock is flush with the top of the punching. The work is thus pushed back into the stock in the same position that it occupied before it was severed from it, and, in many

materials, when the work has been nicely done, one would scarcely notice that the blanks had been severed from the stock. This condition is taken advantage of oftentimes in clock manufacturing. Gear blanks, for instance, are punched out from strips of metal and inserted back in their places again, minus, of course, the stock which has been punched out to form the arms and the hole for the "staff" or little shaft on which it is mounted. These strips, thus prepared, are then taken to machines where the staffs are inserted and fastened, it being much easier to handle the little wheels in this way than if they were severed and handled in bulk.

Besides the advantages of permanent setting of the punch and die and the holding of the stock to prevent distortion, which allows very narrow bridges of material to be left between wide openings, the suitability of the sub-press for delicate work, such as the piercing of small holes in thick stock, will be appreciated by reference to Fig. 3. It will be noted that, no matter how small punches *e* and *f* may be, no portion of their projecting ends is at any time left unsupported laterally by shedder *H* or by the work. The shedder, pressing down firmly on the work, supports the end of the punch at the point where the pressure is applied. It is thus possible to use a very much more slender punch for a given thickness of stock than can be used in ordinary dies.

**Sub-press Die for Blanking and Forming Copper Cups.**— The die shown in Fig. 4 was designed to blank and form up a copper cup or capsule used in the manufacture of balance wheels for watches. The copper strip is fed into the press, which then blanks out and draws the metal into the shape shown at *R*, at the same time punching the center hole. Referring to the illustration, *A* is the base of the sub-press, *B* the body, *C* the cap, and *D* the plunger, all these being of cast iron machined to size. The body and base are held together by two screws *E* after the usual well-known manner; *F* is the buffer plug which receives the thrust of the press piston; *G* is the babbitt lining of the body *B*; *H* is the outside diameter die, held in place by four screws and two dowel-pins; *H*<sub>1</sub> is the outside diameter



$H_1$  and drawn to a cup shape between the inside edge of  $H_1$  and the outside edge of  $I$ . Simultaneously, the center hole is punched by  $J$  and  $I$ . As will be seen by referring to the illustration,  $J$  is made a trifle short, so that the drawing operation will have begun before this hole is punched; this prevents any distortion of the piece by the punch  $J$ . A little trouble was experienced with this tool at first, on account of the air in the hollow plunger  $D$  forming a cushion when it was compressed by the rising of the piston  $M$ , thus preventing the proper working of the die. This was finally obviated by making a small groove at the side of the piston where it worked in the plug  $O$ , and drilling a vent hole through  $O$  as shown. This allowed free communication to the

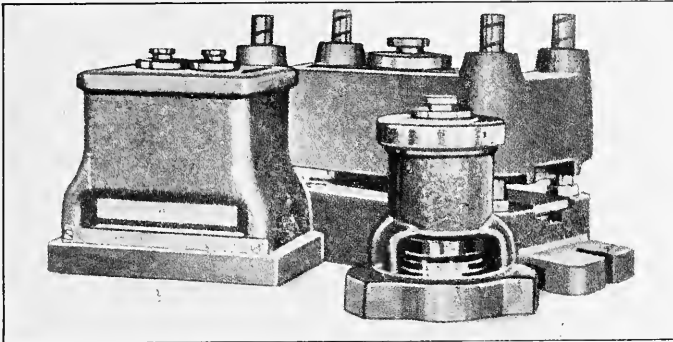

Fig. 5. Three Forms of Sub-presses

atmosphere, and from then on the die gave complete satisfaction. The variation in size among the cups, or capsules, as they are called, is never more than 0.001 of an inch either in diameter or in length.

**Large Sub-press Dies.**—The sub-press construction is employed for many large dies, as well as for those used in the production of small delicate work, although in their arrangement the larger sizes differ from those previously referred to. The circular type, which is commonly used for small work, is shown in the foreground of Fig. 5, whereas larger sizes may be seen at the left and rear. The die at the left has a plunger of rectangular shape. This operates in a bearing lined with babbitt metal, the same as the cylindrical form, although the bearing is not ad-

justable. The larger sub-press seen at the rear of the small plunger type has a sliding head or upper die which is guided by four vertical posts, carefully ground and lapped to fit cast-iron bushings. This is a construction commonly used on heavy work. The same advantages that obtain in the use of smaller

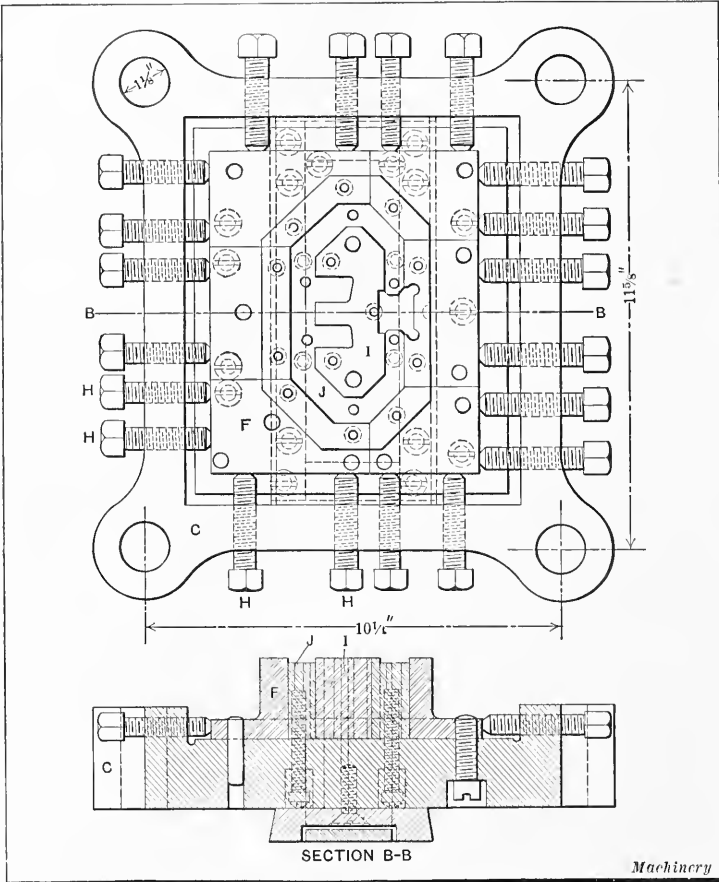

Fig. 6. Sectional Die which Operates on Sub-press Principle

sub-presses result from the larger sizes; that is, there is a saving of time in setting up the tools; there is a greater possibility of punching small holes in thick stock and of leaving narrow bridges of metal between openings of considerable area; the dies, owing to their accurate and permanent alignment, may be

fitted to each other much more closely and produce parts that conform to the required dimensions within small limits.

**Sectional Sub-press Die.** — A sectional or built-up die, which is built on the sub-press principle, is shown in Fig. 6 and the punch (which is the lower member) is illustrated in Fig. 7.

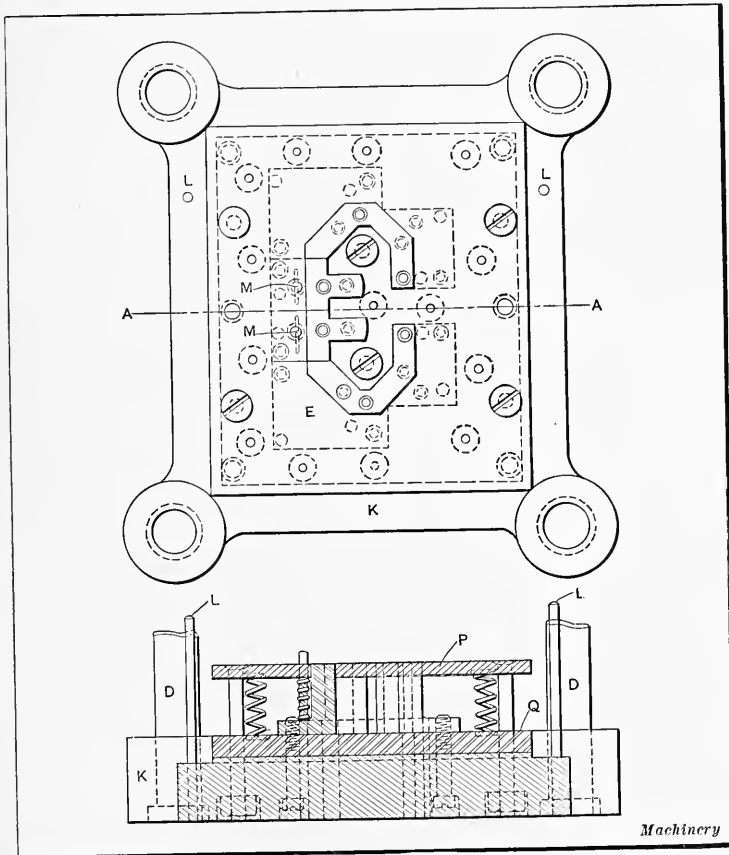

Fig. 7. Punch for Die Illustrated in Fig. 6

The plan view of the punch also indicates the irregular shape of the blank which is produced. The die is so constructed that the blanks can be changed to different shapes by simply inserting different die sections in different places of the die. At *A*, Fig. 8, is shown a modification of the blank, possible with this die. Another of the principal features of this sub-press sec-

tional die is the means for stripping the scrap and ejecting, when it is wanted to produce punchings in quantities. The die may appear to be unduly light in construction, but several sets have been built on these lines and have given full satisfaction. Their light weight materially lessens the cost of handling, as well as the cost of making. The holder *C* is of good, close-grain cast iron planed on both sides. At the top, a recess is milled with an end-mill in a vertical miller. In this recess are held the sectional parts of the die, which are fastened to the body from the bottom. After having made the necessary templets, the

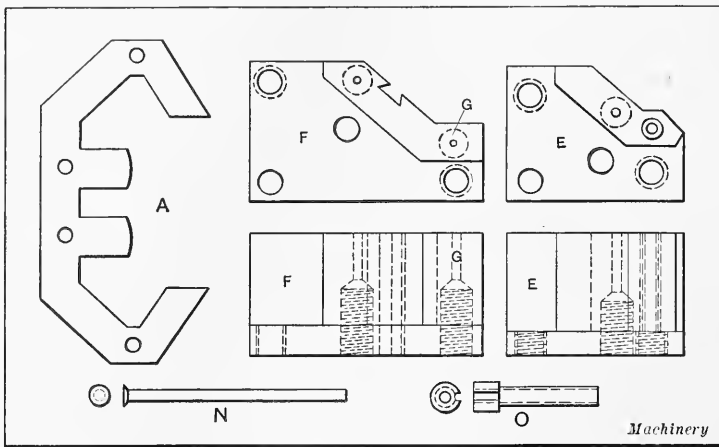

Fig. 8. Details of Sub-press Die shown in Figs. 6 and 7

various die sections are shaped. A few thousandths of an inch are left on the adjoining surfaces to permit finishing by grinding. The cutting edges of the die sections must be left as hard as possible. Die section *F* is shown in detail in Fig. 8. It will be noticed that two small holes are drilled in the center of the two screw holes in the piece *F*. This is done to enable transferring the screw holes to the cast-iron holder when assembling the die. The bottoms of the die sections are left soft in order to be able to drill all the screw and pin holes through the cast-iron holder at the same setting. Each section is reinforced on the two outer sides by four set-screws *H*, as shown in Fig. 6. In the center of the die a solid block *I* is fastened with three screws and



two dowel pins. This block is hardened and ground all over to the shape of the templet. The ejecting or stripping device *J* for the die is made of a solid tool steel piece to the same shape as the templet, but is a very free fit. This part is left soft and is located a few thousandths of an inch more than the thickness of the punching below the top of the die. When the die is sharpened, the stripper is ground off the same amount. No springs are used with the stripper, it being actuated by two 1-inch studs fastened with screws on the stripper. These studs pass through the die and holder, and are actuated by a bar fastened to the gate of the press, thereby forcing out the punchings from the die. The six punches *N*, Fig. 8, are upset, as shown, at the end where they are inserted in the holder, while the other end is hardened, straightened, and lapped to size. The holes for the punches are located after the die is finished and assembled.

The cast-iron punch-holder *K*, shown in Fig. 7, is planed on top and bottom and across the four bosses. The four sub-press pins *D* are of tool steel, hardened as far as the head, ground to a light driving fit on the head end, and ground to a sliding fit in the die-holder on the other end. The holes for these pins were located so as to come in line with each other, and at the same time square with the punch and die. After the punch and die parts were hardened, they were placed together with two parallels between the castings, the punch being entered into the die, and the two clamped together with four C-clamps. In this way the holes for the four guide-posts were machined so as to be in accurate alignment.

A punch part is shown at *E*, Fig. 8. In locating the positions for the piercing bushings *O* (see detail view) it sometimes happens that the holes for the bushings are so numerous and small that they cannot be conveniently bored. The holes are then transferred by a drill that runs through the die and is of the same size as the piercing plug, the die being used as a drill jig. After drilling, the holes are counterbored to the right size for a driving fit for the bushings. The latter are hardened and ground all over, and the holes in them taper one-half degree. A straight dowel pin, driven in so as to be located halfway in

the bushing, and halfway in the section *E*, holds the bushing in position while in operation. A stripper plate *P*, Fig. 7, is placed over the punch sections and has a free fit on both the inside and outside. It is held by flat-head screws which are adjusted with nuts from the bottom of the holder. Between the stripper and the punch-shoe (*Q*), which is made of tool steel and hardened, sixteen spiral springs are placed to strip the metal. The punch-shoes are secured to the cast-iron holder *K*.

Two guide pins *L*, for the stock, are driven into the top of the cast-iron holder *K*, and two gage pins *M* are located  $\frac{1}{16}$  inch from the cutting edge. A small wire is driven through the gage pins, below the stripper, having a spiral spring underneath, which latter is seated on the punch-shoe. When the die comes down, forcing down the stripper plate, the gage pins follow, coming up again on the upward stroke.

**Making Sub-press Dies.** — The making of sub-press dies requires both skill and experience, but a general idea of the method of procedure may be obtained from the following pages, as the principal operations connected with sub-press die construction are described. As the practice referred to is that of the shop or tool-room in which the die under consideration was made, it may not conform altogether with the methods employed elsewhere, although an attempt has been made to present only approved practice.

In making the sub-press die shown in Fig. 2, the base *B* and cylinder *A* are first machined and fitted together according to methods that would naturally be pursued by any good mechanic. The inner surface of the cylinder is grooved lengthwise (as shown by the section *X-Y*) so that the babbitt may be securely locked against rotary movement. Plunger *D* is then machined, and the outer surface ground and fluted lengthwise with semi-circular grooves. Especial pains are taken to have these grooves parallel with the axis of the plunger in both planes; if this is not done the die may be given a slight twisting movement instead of the perfectly straight forward one that is required, since upon these grooves depends the angular location of the punch and die with relation to each other. The plunger

is now inserted within the cylinder and, with proper precaution, the space between them is filled with babbitt which flows into the grooves in the cylinder and those in the plunger as well, locking with one and guiding the other. After being cooled, the plunger is pumped up and down to insure a perfect bearing, and the nut *U* is screwed down until all slack is taken up. Die *K* is now made to accurately fit the templet or model furnished the toolmaker as a sample. After it has been completed, it is hardened and fastened in place. Then the model is inserted within it, and such holes as may be required in the blank are transferred to die pad *G*. This is done by punches with outside diameters ground to fit the holes in the templet, and provided with sharp points concentric with the outside. The pad, after being thus prick-punched, is put on the faceplate, the slight punch marks are carefully indicated, and holes are carefully bored to a taper to fit the punches which are to be inserted in them. The punches are finished by grinding on centers after they are hardened. They are supported at the shank by a male center, while the opposite end is temporarily ground to a point which revolves in a female center in the other end of the grinder. The punch may thus be ground all over with the assurance that the pointed end is true with the exterior—a necessary provision, as will appear later.

It might be noted here that no draft is given to any of the cutting edges of these tools, since they do not enter each other, at least not to any appreciable extent, and since the stock in entering and leaving the cutting edges is positively moved, no clearance is necessary, and the die cuts practically the same kind of a blank throughout its life. Shedder *H* is fitted to die *K* and the holes for the punches are transferred to it in the same way as for the die pad, by means of carefully machined prick-punches which fit the holes in the models, these prick-punch marks being afterward indicated to run true on the faceplate. The punch is now worked out a very slight amount larger in all its outlines than the die. The model is laid upon it and the holes transferred to it, as in the case of the other parts; these holes are then indicated and bored out, but not ground in this case,

being left three or four thousandths of an inch smaller in diameter than finished size. The punch is fastened in place in the base and aligned as nearly as possible with the die. The ram is forced downward in a screw press until the punch enters the die very slightly, cutting a thin chip from its sides to bring them to the shape required. The punch is then worked down to this point all around and again entered in the die a short distance further, the operation being repeated until the two parts fit perfectly.

In finishing the holes in the punch, after the hardening process, small brass plugs are first driven into each hole. The punches *f*, Fig. 3, still with their ends pointed concentric with their outside surfaces, are fastened in position in the upper member, and the ram is brought down until these punches mark slight centers in the top of the brass plugs, when the ram is again raised and the punch *J* (Fig. 2) removed. The punch is then strapped to the faceplate and each of the small plugs is in turn indicated from the prick-punch marks, when it is removed and the hole is ground to size with a steel lap charged with diamond dust in an internal grinding fixture. The stripper is fitted to the punch in the usual manner. With the parts thus made and fitted great accuracy is obtainable.

**Construction of a Sub-press Die for Washers.** — In order to avoid a complicated drawing and to set forth the principles of sub-press die construction in such a way that they may be readily understood by those not familiar with this work, the die used for punching an ordinary washer has been selected for an illustration. The general principles of sub-press dies are, of course, the same whether one or one hundred punches are employed. Having selected a frame or "barrel" of the circular form shown in Fig. 9, it is placed in a chuck, being held by the upper end, and faced off on the bottom; the recess *A* is also bored to fit snugly the corresponding boss on the base of the press. This base is finished on both top and bottom, and the boss on it is turned to fit the bottom of the frame. The center is recessed to receive the stripper plate and blanking punch, and a hole is drilled completely through to allow scrap punchings

to fall to the floor. The base and frame are then fastened together by means of bolts and dowel pins, as shown. Together they are clamped to the faceplate of the lathe, being centrally located by means of a plug center which fits into the lathe spindle and passes through the hole in the center of the base. In this position the frame is bored out to a taper of about one-half inch per foot. After boring, a splining tool is substituted for the boring tool, and with the lathe locked by means of the back-gears, three or four grooves *B* are cut the entire length of the bore by sliding the carriage back and forth. At the same setting the upper end of the frame is faced off and threaded to receive the cap which is screwed on the frame. After the cap is in place, the hole for the plunger in this cap is bored out to the required size. This insures the hole in the cap being central with the inside of the frame.

The plunger (which is also shown in detail) is the next piece to receive consideration. After being centered and rough-turned, it is put in the center-rest, and the hole *C* bored and threaded and fitted with the button by means of which connection is made with the press slide. The internal thread in the plunger is carried down to a considerable depth in order to allow of the insertion of a tension cap, by means of which a sufficient tension is placed upon the stripper spring to force the punching back into the stock upon the return stroke of the press. A dog is fastened to the button and the plunger turned to fit the hole in the cap, great care being exercised to keep the sides perfectly parallel. After turning, the lathe is blocked by the back-gear, and three grooves *E* are splined, about  $\frac{1}{16}$  inch deep, for the entire length. It is essential that these grooves be parallel with the axis of the plunger. Before the plunger is completed, a ring,  $\frac{3}{4}$  inch wide, is made of machine steel and forced onto the lower end of it. The outside of this ring is trued up, using the plunger as an arbor, after which this end of the plunger is placed in the center-rest, where the ring prevents it from being scored or injured by the center-rest jaws. In this position the recess *F* is bored to receive the punch-holder *K*.

The punch-holder is made, as are also the die stripper and

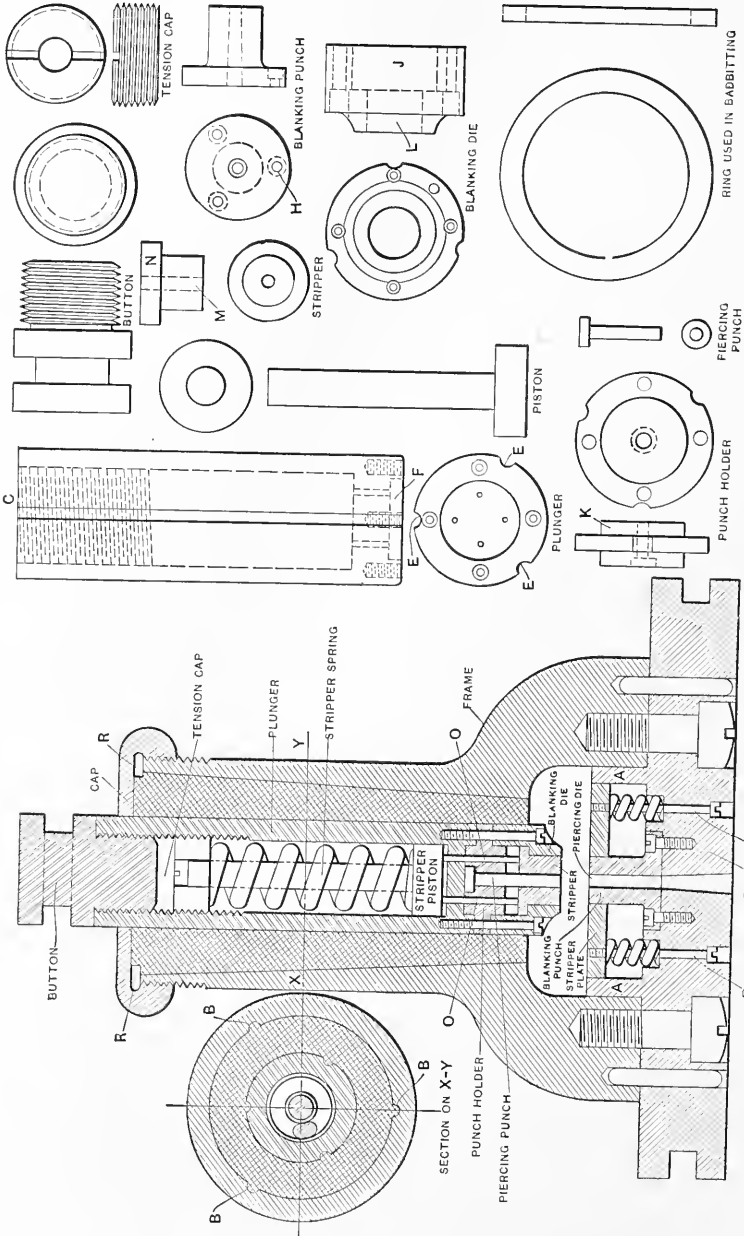

Fig. 9. Sub-pressure Die for Blanking and Piercing Washers

piercing punch, by turning from a bar held in the chuck and finishing complete before cutting off. The recess which receives the head of the piercing punch should be bored at the same time to insure its being central with the rest of the die. The stripper, which is placed inside the blanking die, should be made of tool steel and left large to allow for grinding after hardening, while the hole is bored sufficiently small to allow for lapping to exact size. The blanking punch, which also forms the piercing die, is made of tool steel in the same manner, being finished completely before it is cut off, and it is left with sufficient stock to grind after it has been hardened. The holes *H* are drilled and counterbored for screws to hold the punch to the base.

After the parts are hardened, the blanking die is the first to be ground. It is gripped in a chuck, upper end outward, and the large hole *J* is ground out to fit the step *K* on the punch-holder. Then the hole *L* is ground perfectly straight and of the same diameter as the master templet. The top face is also ground off, thus completing the die. In the stripper, the hole *M* is lapped to the same dimension as that in the templet. A round piece of cold-rolled steel is gripped in a lathe chuck and turned to fit nicely this hole in the stripper. Without disturbing the chuck, wring the stripper onto this arbor and grind the flange or shoulder *N* to fit nicely the larger bore, and the smaller diameter to fit the smaller bore, of the die. The blanking punch is finished in exactly the same manner as the stripper, being ground to fit the recessed seat in the base. The minor parts, such as the stripping plate, stripper piston, pins and springs, are then made, and the press is ready for assembling.

In assembling, first force the punch-holder into the seat *F* of the plunger, and then force the die onto the holder; transfer the holes in the die through the holder and into the plunger, and after they are drilled and tapped, fasten the parts together as shown in the sectional view of the assembled die. Remove the die and drill four holes in the punch-holder and plunger for the stripper pins *O*. Place the stripper piston in the plunger, above this the spring, and lastly screw the tension cap into place. The stripper pins *O*, which are hardened for their entire length,

are placed in their holes in the punch-holder, and the stripper placed in the die, which is then secured to the punch-holder.

The blanking punch is placed in its seat in the base and securely fastened by cap-screws, after which the springs shown are placed in position and the stripper plate drawn down by means of the screws *P*, until it is a trifle below the top of the blanking punch. The frame is now ready to be babbitted. Screw the button onto the plunger, and with a piece of oily cloth wipe the plunger all over, then sprinkle flake graphite onto it. The oil on the plunger will cause the graphite to adhere, and after the surplus graphite has been blown away, a thin coating will be left over the entire surface. The plunger is lowered inside of the frame until the blanking punch enters the die. In the cap insert the babbitting ring (shown in detail in the lower right-hand corner), to prevent the babbitt from flowing into the recess *R*, and screw the cap onto the frame. As the cap is an exact fit for the plunger, it therefore aligns it with the frame and with the blanking punch. The grooves on the plunger must be plugged with putty where they pass through the cap, in order to prevent the escape of the babbitt while pouring. A pair of parallels, of a height equal to the projection of the button beyond the top of the cap, are now placed on the bench, and the die is placed in an inverted position upon them. Great care should be taken to avoid any vibration during pouring, as very little will affect the alignment of the plunger. Before pouring, heat the frame with a torch or jet of gas, and when the babbitt has attained the proper heat, which is a very dark red, pour it in from both sides of the die simultaneously. Allow it to remain until thoroughly cool, then remove the plunger, strap the frame to the faceplate of a lathe, and cut a spiral oil groove the entire length of the babbitt.

As the blanking punch has already been ground, the next step is to grind the faces of the blanking die, piercing punch, and stripper, while all are in their proper positions in the plunger. They should be ground so that the face of the stripper, die, and punch are all flush with each other. After grinding, the parts should be taken from the plunger and thoroughly cleaned, so



that there will be no abrasive in the working parts. Oil all of the running parts in a thorough manner, then put them together in their proper positions, and replace the plunger in the frame. In setting up a sub-press die, care should be taken to have the punch come only to the face of the die, and not enter it to any appreciable extent.

**Making Sub-presses at Illinois Watch Co.** — As previously mentioned, sub-press dies are extensively used in the manufacture of watches and clocks, owing to the precision and rapidity with which small wheels, gears, etc., can be blanked out from sheet stock. The general practice in the diemaking department of the Illinois Watch Co., in making sub-presses of the piston or plunger type, is as follows:

The casting for the upper part or body of the sub-press is first put in a lathe with the rough barrel in the chuck, the bottom faced off, and the bottom or base hole bored out, as shown at *A*, Fig. 10. The body is next strapped, barrel outward, onto a faceplate, and centered by a plug which is usually a piece of brass driven into the center hole of the lathe spindle, and then turned to fit the base hole in the casting. The barrel is now turned on the outside and bored taper inside, the outer end or top being the largest. Three or four (usually three) grooves are next cut in the bore, as shown at *B*, by traversing the carriage along the bed with the work held stationary. The taper attachment is used to guide the tool along the tapering bore. The piece is removed from the faceplate when it is ready for the next operation, which is casting the babbitt. In performing this operation, the sub-press body is placed on the special base *C*, which just fits the bored hole in the bottom of the body. The piston *E* is then slipped into place, and is held central with the bore of the barrel by holes in the center of the special base *C* and in the cap *D*, which is next put on. It should be stated that in actual use the special base *C* fits up into the body so that its top covers the bottom of the bored barrel, in order to keep the melted babbitt where it is wanted, the base and body being held tightly together during the casting process, by two C-clamps. In taking the photograph from which this illustra-

tion was made, the body was purposely set up, as shown, in order to give a better view of the positions of the piston and the way it is held. The piston *E* has been previously ground perfectly true from end to end and has had three grooves cut lengthwise in it. It is also blackened with carbon, by holding it in a smoky flame, before it is put into the casting jig. The babbitt, which is made up of tin, antimony, and a large percentage of copper, is now poured around the piston through the opening *F* in the cap *D*. Just as soon as possible, the work is cooled off in water — the sooner the better. The piston is now pressed out by means of a screw press. After being removed, the piston

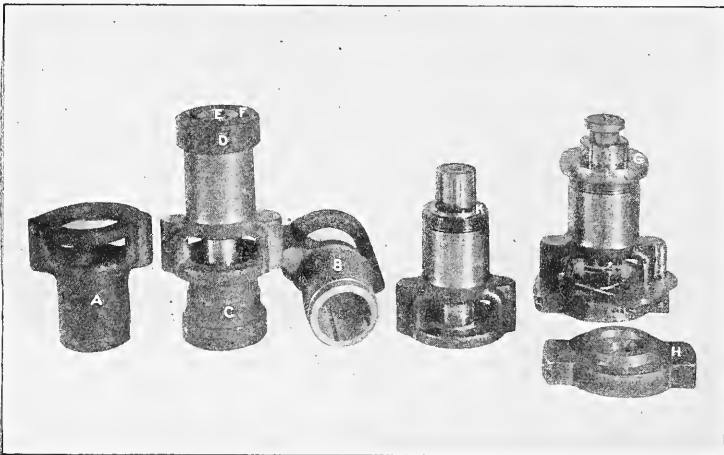

Fig. 10. Sub-press Parts and Jig used for Babbitting Plunger

is carefully lapped with a copper ring-lap and emery, and the grooves are also lapped until the piston can be worked in and out of the barrel with some degree of ease. A cap like the one shown at *G* is next fitted on so as to hold the babbitt firmly in place, for while the taper bore of the barrel prevents the babbitt from going down, it does not keep it from being pulled up. The body and piston are then put into a punch-press and “pumped” at a good rate of speed for some time in order to wear them in, the “spots” on the babbitt being carefully scraped from time to time. When worn in a sufficient amount, the piston is removed and carefully re-centered in a lathe, a bored

ring being used to hold it. The piston is again replaced in the barrel, put between centers, and the bottom and bored hole of the body carefully trued up. In this way any inaccuracy that may have resulted from the preceding operation is corrected and the outside of the piston, its centers, and the bore of the bottom of the body are made absolutely concentric. The base *H* of the sub-press is next fitted, doweled, and fastened to the body by two fillister-head screws. The bottom of the base is then trued up by taking a light cut over it, using the piston as a mandrel.

The idea of making the bore of the barrel of the sub-press taper, is not simply to keep the babbitt from dropping down, as a shoulder would answer for that; but the main reason is that if the piston becomes loose from wear at any time, the babbitt, which has been left high on top, as shown at *K*, can be forced downward by using a ring and a powerful press, thus taking up the wear. The retaining ring or cap on the top of the barrel is not powerful enough to do this, as it is only intended to keep the babbitt from coming out, as stated.

As a general rule, in fitting a punch and die into a sub-press, the master punch is fitted into the piston as explained, and a die blank, the top of which is tinned with solder, is fitted into the base. The punch is then brought down and an impression of the outline made in the solder. The die blank is then removed and drilled out as close to the lines of the impression as it is safe to do, after which the die is slowly and carefully worked out and finished, using the master punch as a guide.

**Points on Sub-press Die Construction.** — In constructing sub-press dies it is important to have a good stand or frame, because upon its construction depends in no small measure the proper working of the die. If the stands are well made, they can be used indefinitely for different dies, owing to the adjustment provided for wear. It is a disputed point whether the plunger should be babbitted before or after the punch and die are fitted. Some prefer to make the punch and die first, enter the punch into the die attached to the plunger, and pour the babbitt, but it is generally conceded that the better way is to babbitt the

plunger first; in fact, most manufacturers at the present time buy them already fitted up from one of the several companies manufacturing them for the trade. One advantage in having the plunger babbitted first is that it can be run continuously for a day or so to secure a good bearing, the cap-nut being set up occasionally. In this "working out," the plunger is sure to "creep" or change its position slightly; this is probably caused by the babbitt not flowing evenly and, obviously, it is much better for this change to take place before the alignment of the punch and die. In recessing the cylinder or frame to receive the base, the proper way is to place the plunger on the centers of the lathe with the cylinder attached and recess and face out on the bottom, using the plunger for a mandrel. With this method (which is applicable when the plunger is babbitted first) one has the assurance that the plunger is exactly central and in a vertical position with the base.

In milling the three grooves in the plunger, it is well to space them unevenly, as it will then be impossible to insert it in any but its proper position. In locating the holes in the back-plate and shedder, a round master plate is usually used, thus insuring greater accuracy. This master plate can also be used for duplicating the die, if, at any time, this should be necessary. In boring the holes in the master plate, they should be made a trifle larger than the largest hole in the work, which gives clearance for the boring tool to pass through. When boring the back-plate, it should be set perfectly central with the master plate and then be fastened with a drop of soft solder on opposite sides. Having done this, a taper pin is inserted in the center of the faceplate of the bench lathe, and turned up on the end that projects, to the size of the holes in the master plate. One of the holes in the master plate is then wrung onto the pin, after which the master plate is clamped to the faceplate and one of the holes bored. The work is then located for boring the remaining holes by shifting the master plate in the usual manner. The holes should be left small, so as to correct the error from hardening, by grinding.

When grinding, the work is placed upon the master plate in

the same manner and position as when boring, the grinding being done by means of a steel lap several thousandths smaller than the hole, the enlarged end of which is charged with diamond dust. In separating the die from the master plate, the best way to remove the solder is to turn it off with a lathe tool before the work is removed from the faceplate.

When making the die, great care must be exercised, as the die is straight and the templet must be worked through without any clearance; this allows an even sliding fit for the shedder. In case it is impossible to avoid a little clearance, it can sometimes be corrected in the lapping operation, after hardening.

**Making a Sub-press Die of the Four-post Type.** — A sub-press die of the four-post type is shown in Fig. 11. This sub-press is used for making a part having rack teeth, the shape being indicated by the illustration. The punch and die are finished before the upper and lower members are aligned with each other. When aligning them, the punch is entered into the die, the faces of the two parts being parallel with each other; then bushings *A* are slipped over the guide-posts until they rest in the bottoms of the cast counterbores of the die-holder *B*. (See upper left-hand sectional view.) This counterbored space has large pockets gouged out at the sides for the babbitt to flow into and form anchorages. The helical oil grooves, with which these posts are subsequently provided, are not yet cut, the posts being smooth and true as left by the grinding operation. After the space *C* is filled with babbitt, the punch and die are securely held in alignment with each other. The guide-posts are then removed and the helical grooves for oil distribution are cut in them.

One of the noticeable features of this die is that the section of the cutting edge which shears out the rack teeth is built up of small segments, each containing two teeth only, these segments being dovetailed into the larger piece, *K*<sub>5</sub>. Each of these small pieces, *K*<sub>8</sub>, is secured by two dowels which lock the parts firmly together. This costly and difficult construction was necessitated by the demand for accuracy in the spacing of the teeth. With the sectional construction shown the parts are not affected



sensibly in the hardening. That piece  $K_5$  may not be warped out of shape, it is ground to size in all its surfaces, top, bottom, sides, and even in the dovetail, so that when completed its plane surfaces are straight and parallel. The dovetail of the die sections  $K_8$  are next machined to fit the groove in  $K_5$ . The holes in  $K_5$  are then continued to pieces  $K_8$ , which are taken out and hardened, and returned to be doweled in place. It will be seen that this die is constructed on the sectional plan throughout. This makes it possible to finish most of the cutting edges on the surface grinder. Troubles due to distortion in hardening are thus entirely avoided. The proper end measurements between important points in the model are also preserved by leaving a slight amount of stock where two sections of the die come together, the parts being ground away at this point until the proper dimensions are obtained.

In the few cases where the grinding wheel will not finish the cutting surface, extended use is made of diamond laps, these being in the form of steel sections of proper contour to fit the part of the die they are working in, these steel pieces being charged with diamond dust and reciprocated vertically in filing machines. The little dovetail in which part  $K_7$  is inserted, for instance, was finished in this way. The back of the dovetail is perpendicular but the two sides slope somewhat from the vertical, forming a wedge-shaped opening enlarged toward the rear. Section  $K_7$  is driven in from the rear, finished off, and ground with its front face flush with the rest of the die.

This sub-press die is for the first operation on the blank. The pieces produced are afterward subjected to the action of a shaving die, the original blanks being left with 0.002 or 0.003 inch stock for the purpose, which is trimmed off in the last operation. The punch for this first or blanking die (see lower view, Fig. 11) has the rack section subdivided into four parts only, which are matched up carefully with the sectional die just described. In the shaving die, however, this punch is built in sectional form as described above for the blanking die, so that great refinement in measurements is secured.

A feature of the shaving die, to which reference has been made,

is the use of a "nest" to locate the work. In this trimming operation the punch is in the upper member and the die in the lower one. On the surface of the die, which is similar in construction to the one shown in Fig. 12, are placed steel guiding plates,  $U_1$  and  $U_2$ , which form the nest referred to. They have their edges shaped to the outline of the piece to be operated upon and are pressed inward by flat springs  $H$  at the outer edge,

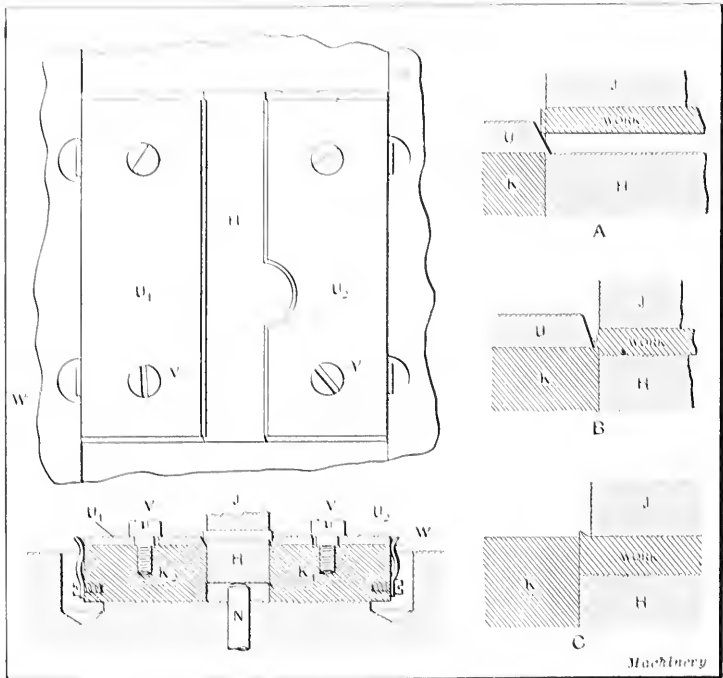

Fig. 12. Shaving Die with Nest for Locating Work — Detailed Views Illustrating Action of Locating Plates

being allowed a slight lateral movement although prevented from being displaced by shoulder screws  $V$ . The holes through which these screws pass are slotted to permit this; the end of the slot limits the inward movement of the plate. As shown in the enlarged views,  $A$  and  $B$ , the inner edges of these plates are beveled backward so as to form a recess in which the work may be located. The descent of the punch forces out the plates (as at  $B$ ) which, as they are displaced, still guide the work so that



it is properly centered over the die. These beveled edges of the plates have the further advantage of curling the chip out of the way where it does not clog the tool and may be easily cleaned off. The shedder *H*, which comes up from below and removes the work, closes the lower opening effectively so that the whole device is chip-tight.

Even greater accuracy is advisable in the fitting of the punch and die in this shaving sub press than is necessary in the one

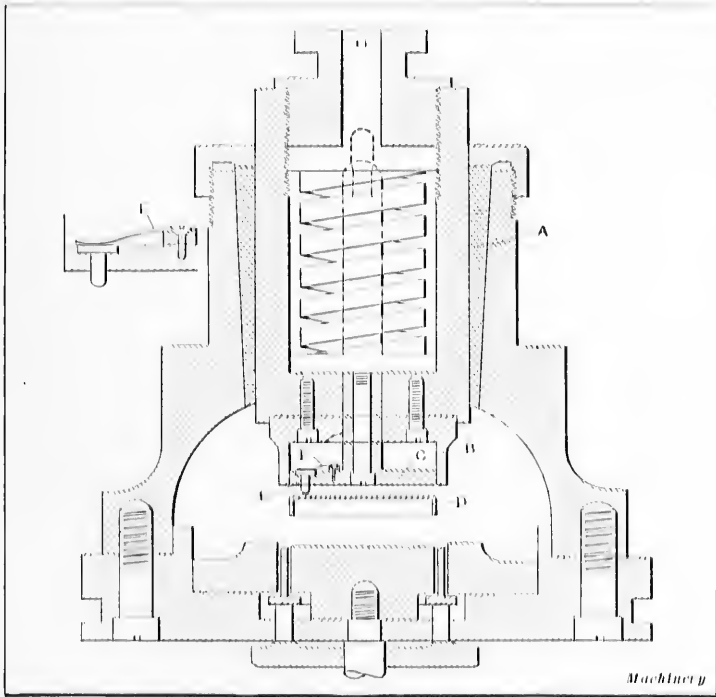

Fig. 13. Sub-press Die Equipped with Secondary Knockout Pin E

used for blanking only, if it is desired to produce clean work free from burrs. The necessity for this will be appreciated upon examining detailed section *B*, which shows in magnified form the action of the cutting edges. If the punch does not match up closely with the edge of die *K*, the stock is bent upward, leaving a sharp burr, while the punch impresses the outline of its cutting edge on the top surface of the blank.

**Stripping Blanks that Adhere to Punches and Ejectors.** — Every diemaker or press hand is familiar with the troublesome, disastrous effect of having drawn and blanked pieces cling long enough to the ejector, or knockout, for the punch to descend upon a new piece of stock and also the punching just made. The outcome is likely to be a broken die. When using a sub-press die similar to that shown in Fig. 13, which is for blanking and drawing shallow cups, many thousand cups may be drawn

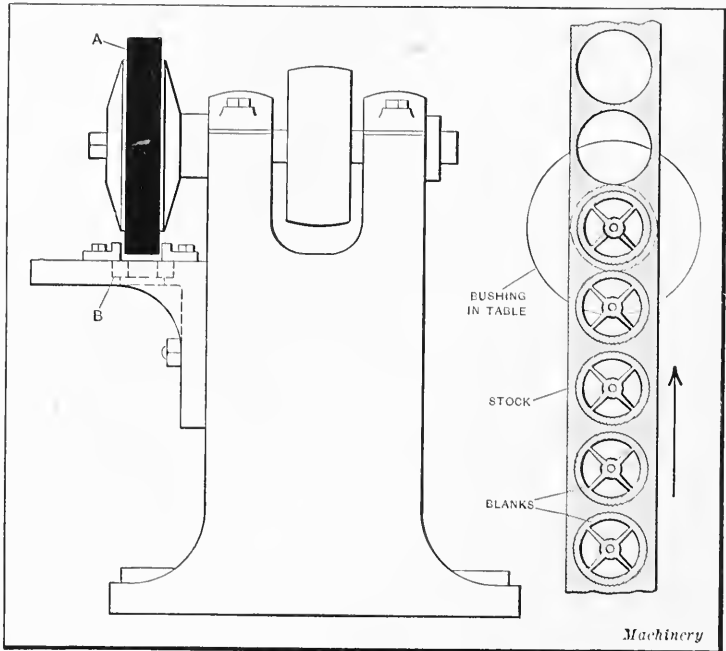

Fig. 14. Machine for Separating Blanks from Stock which has passed through Sub-press Dies

without any mishap, especially if little or no oil is used on the stock, but without oil the life of the drawing die is shortened, or if copper or brass is being drawn, the metal tends to amalgamate with the die which, at intervals, must be taken down in order to remove this amalgamated material. On the other hand, if enough oil is put onto the stock to keep the dies in good condition, the cups or blanks may adhere to the face of the knockout long enough to cause trouble. The simple device shown in

Fig. 13 will prevent difficulty from this cause. The cast-iron plunger *A* carries the hardened drawing die *B* into which the knockout *C* is inserted for pushing the drawn piece from the die. If the cup *D* should cling to the face of the knockout by oil contact, the secondary knockout pin *E*, operated by a flat spring (see enlarged view), would force the work away from the face of the knockout as soon as the cup was pushed out of the drawing die. As spring *F* is strong enough to break any oil contact, the work is caused to drop immediately and the result is that the die can be operated at a much higher speed. The particular cup shown is  $1\frac{3}{4}$  inch in diameter,  $\frac{3}{8}$  inch high, and 0.02 inch thick.

**Separating Sub-press Die Blanks from Scrap.** — When flat blanks are cut in compound sub-press dies, the blanks are pushed back into the openings from which they were cut by the action of the stripper, and if the stock is much over 0.02 inch thick, considerable trouble is sometimes experienced in removing the blanks. Fig. 14 shows a machine that is used for forcing the blanks from the strip of stock without marring them. This machine is equipped with a soft rubber wheel *A* which, as the illustration shows, is supported on the sides by steel flanges which are quite large in diameter in proportion to the diameter of the wheel. The table of the machine is formed by a knee or angle iron which is provided with adjustable guides, and is recessed to receive bushings *B* having different sized holes. Before using this machine, a bushing is inserted in the table having a hole somewhat larger in diameter than the diameter of the blanks to be forced out of the stock. The guides are then adjusted to allow the strip to slide through freely, after which the table is raised until the rubber wheel bears against the stock with a slight pressure. The wheel is then rotated by power, and it is simply necessary to place the end of the strip under the wheel which will then automatically feed it along, at the same time forcing out the blanks through the hole in the bushing. The diagram at the right illustrates how the blanks are fed out of the scrap as they pass between the bushing and the rubber wheel.

## CHAPTER VI

### SECTIONAL PUNCH AND DIE CONSTRUCTION

Many dies at the present time are formed of sections instead of being cut out of a solid piece of steel. This sectional construction is employed more particularly for large dies, especially when the form is complicated. There are two principal reasons for using the "split" or sectional die. One is that it sometimes happens that the blanks to be cut are of such a shape that the die can be more quickly and cheaply made by making a split die than by making a solid or one-piece die. The other reason is that when the required blank must be of accurate dimensions, and there is a chance of the solid die warping out of shape in hardening, the split die is preferred, because it can be much more easily ground or lapped to shape; moreover, a solid die is liable to be cracked by the hardening process, and in the case of a large die of complicated form this, of course, means a considerable loss. Some dies are also provided with one or more sections, at points on the die-face where the work is severe, so that the die can easily be repaired by simply replacing these sections when they have been worn excessively.

**Examples of Sectional Die Construction.** — Fig. 1 shows the manner in which the ordinary split die is sometimes made. After the die is worked out, it is hardened and ground on the top and bottom. The two sides *A* are then ground at right angles to the bottom. The cutting parts of the die, *B*, are next ground at an angle of  $1\frac{1}{4}$  degree to the bottom, so as to give the necessary clearance in order that the blanks may readily drop through. The key *D* is now set in place, and the die is keyed in the die-bed by the aid of a taper key. The key *D* prevents the die from shifting endwise; the keyway should have rounded corners as shown, which not only give added strength, but also act as a preventive to cracking in hardening. The

last operation on this particular form of die is to grind the two circular holes. This is done by first lightly driving two pieces of brass or steel rod into the holes until they are flush with the face of the die. The exact centers are then laid out and spotted with a prick-punch, care being taken to get the centers central with the sides *B*. The die is now fastened to the face-plate of a universal grinder, and the center mark is trued up with a test indicator until it runs exactly true. The brass piece is then driven out, and the hole ground to size, with  $1\frac{1}{2}$  degree taper for clearance. The other hole is next ground out in a similar manner, which completes the operations so far as the

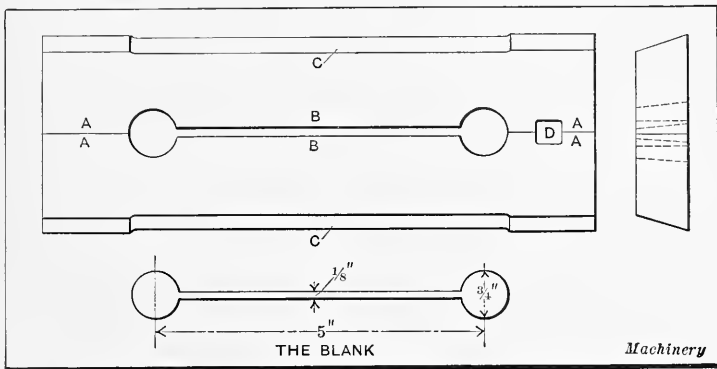

Fig. 1. Simple Example of Sectional Die Construction

die is concerned. It often happens with a die of this kind that when it is placed in the die-bed and the key driven in place, it will "close in." To overcome this, the die is relieved after the manner shown at *C*, which does not in any way prevent it from being securely held in place when in use.

Fig. 2 shows a rather novel form of split die; this die with a slight change practically takes the place of two dies. It is used for piercing slots in brass plates. The size of the slot for one style of plate is  $4\frac{3}{8}$  inches long by  $\frac{1}{4}$  inch wide; for the other plate the slot is 4 inches long by  $\frac{5}{16}$  inch wide. The cutting part of the die is made in four sections, *A*, *B*, *C*, *D*. When cutting the  $4\frac{3}{8}$ -inch plates, sections *C* and *D* are used, whereas, when cutting 4-inch plates, sections *E* and *F* are inserted between the parts *A* and *B*. The soft steel bushings *G* (through which

dowel-pins are inserted) are used to allow for the contortion of the parts *A* and *B* in hardening. It may be added that the four bushings shown in the piece *A* were driven in first; then solid pieces were driven in the part *B*; then the holes were drilled in these latter pieces, being transferred from the bushings in the part *A*. The sections *C*, *D*, *E*, and *F* are hardened only at the cutting ends.

The dies shown at *A* and *B*, in Fig. 3, illustrate how the sectional construction may facilitate making the die and also lessen the danger of spoiling it in hardening. The punch for die *A* was made before the die. This punch consists of a cast-iron holder to which is attached a steel plate forming the punch

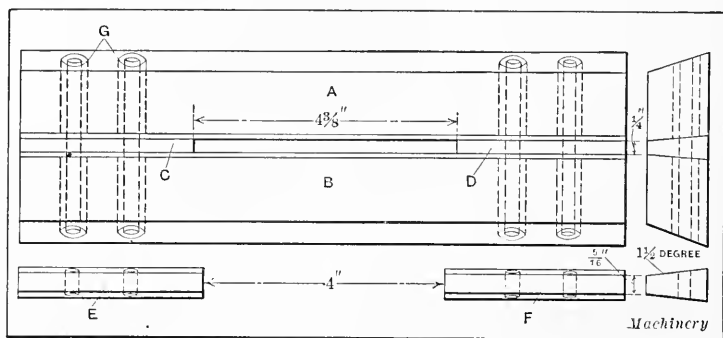

Fig. 2. Sectional Die having Interchangeable Parts so that Two Sizes of Blanks can be Punched by Changing the Central Pieces

proper. After the punch was hardened and attached to the holder by screws and dowel-pins, the outside was ground to the required diameter; then the die was machined and, after hardening, ground to fit the diameter of the punch. The sections *a* and *b* were then fitted to the die and fastened with screws and dowel-pins, as shown. The cutting edges of these sections were then sheared to the required form by means of the punch. As these inserted parts were small they did not change to any appreciable extent in hardening. The punch for the die shown at *B* was also made first. After hardening it and grinding the circular part, the die was ground at *c* to fit the punch. The sections *d* were then fitted to the die and the cutting edges sheared by the punch. In hardening these sections, one of

them changed so much at the point *e* that it had to be discarded and another one made. This did not require any great amount of work, however, but if the die had been solid, obviously, it would have been entirely spoiled.

**Sectional Die for Square Washers.** — The sectional die shown in Fig. 4 is so designed that all the cutting edges and the inside of the die can be machined and ground to the required dimensions without requiring any hand work. This construction makes the punch and die inexpensive to produce, and in event of its being damaged during the hardening process or when placed in operation, the damaged parts can be renewed at a

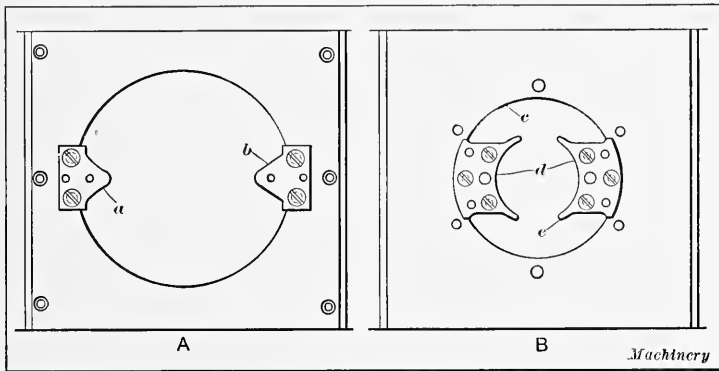

Fig. 3. Examples Illustrating Advantages of Sectional Die Construction

relatively small cost. The punch and die are used in manufacturing laminated copper washers in large numbers. These washers are square and have a square hole in the center; they are produced from sheet copper 0.020 inch in thickness. An inclined power press with automatic roll feed is used, and the finished work slides into a receptacle at the rear of the press.

By referring to the plan and sectional views of the die, it will be seen that there are three piercing and three blanking dies carried on one bolster. The die is made up of fifteen sections which are held together by double dovetail plugs fitting into corresponding holes. When ribbon stock is fed through the die, the holes in three washers are pierced at the first stroke of the ram, and at the next stroke the blanking punch cuts away three

washers with the holes in their centers which were produced by the preceding stroke; at the same stroke, the holes are pierced for the next three washers. The diagram, Fig. 5, shows the order of the piercing and blanking operations. None of the sections of the die have been drawn in detail as they will be readily understood from the assembly drawing. All of the die

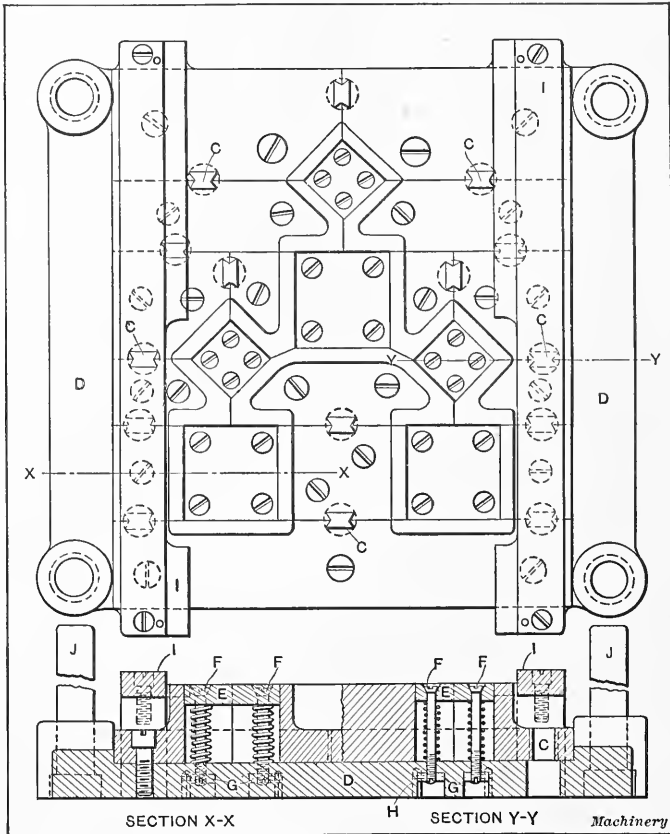

Fig. 4. Blanking and Piercing Die of Sectional Construction

sections are machined approximately to the required dimensions with the exception of the inside or cutting edges, which were left a few thousandths over size to permit grinding them after hardening. The face is recessed on the outer edge to within  $\frac{1}{4}$  inch of the cutting edge and  $\frac{5}{8}$  inch from the bottom, thus



leaving a narrow strip all around the cutting edge in order to reduce as far as possible the surface to be ground.

Each section of the die is held securely to the cast-iron bolster *D* with one or two fillister screws, and the sections are then wedged together with double dovetail blocks *C*. The cutting

edge of each section is hardened down only about  $\frac{3}{8}$  inch and is drawn to a light straw color. When all the sections are assembled on the bolster *D*, the double dovetail holes are laid out with a templet and each of the sections is then milled with a dovetail cutter to receive the clamping blocks *C*. The blocks are made of tool steel, in strips 12 inches long; these strips are then sawed up into

pieces  $\frac{5}{8}$  inch in length and the ends are filed to a slight taper so that they will just enter the holes between the die sections. These blocks are hardened in oil and drawn to a blue color. The die sections are next screwed to the bolster and the dovetail wedges are driven in. This method of fastening holds the die as securely as if it were a single piece.

Each of the piercing and punching dies is equipped with an ejector plate *E* which is a sliding fit in the holes and held in position with four flat-head screws *F*. Spiral springs are placed around these screws to hold the ejector plates in position. The screws *F* extend through the bolster and carry adjusting nuts *G* which fit in counterbored holes in the under side of the bolster. Small holes are drilled in the under side of the bolster, before the counterbored holes for the adjusting nuts are bored. These small holes are then plugged up to keep the drill from running out while counterboring the larger holes for the nuts *G*. When

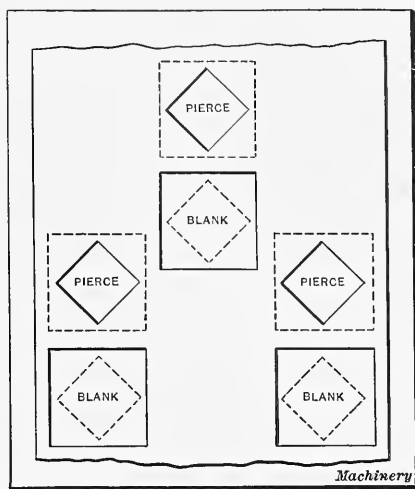

Fig. 5. Diagram Illustrating Piercing and Blanking Operations Performed in Die shown in Fig. 4

the plugs are removed from the small holes, the portion of the hole which was not removed during the counterboring operation serves as a guide in drilling a hole to receive the small pin *H* which is tapped into the nut *G* and keeps it from turning. The ejectors are adjusted by means of the screws *F* so that they are

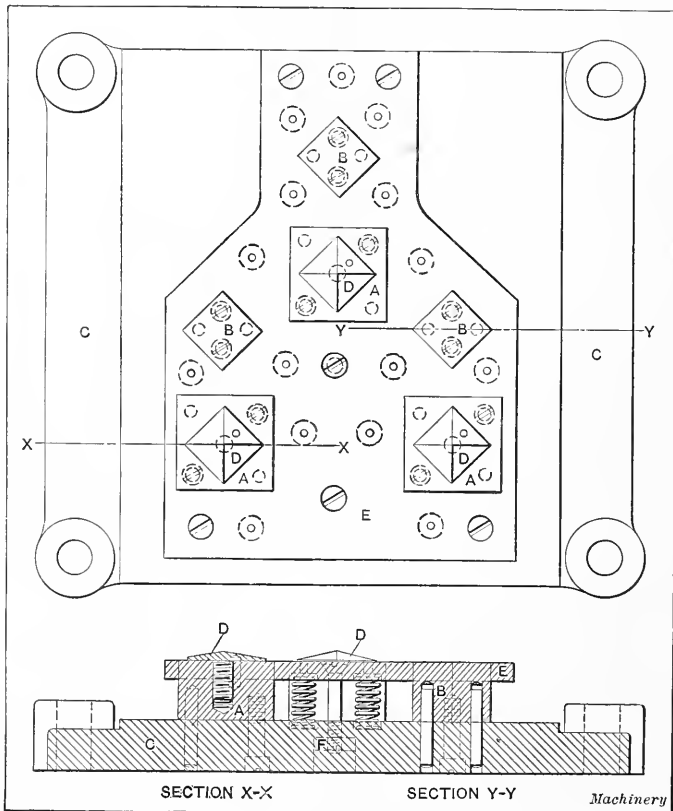

Fig. 6. Plan and Sectional View of Blanking and Piercing Punch for Die shown in Fig. 4

about  $\frac{1}{32}$  inch above the cutting edge of the dies. A long guide plate *I* is placed at each side of the die and fastened in position with fillister screws and a dowel-pin on each end.

The cast-iron bolster plate *D* is planed on the bottom and top and also across the bosses. The four holes in each corner are next drilled, reamed, and counterbored to receive the sub-press

pins *J*, similar holes being made in the punch-holder after the punch and die have been assembled. The sub-press pins *J* are made of tool steel hardened up to the head; the heads are ground to a driving fit in the die-bolster and the pins are ground to a sliding fit in the punch-holder. To locate the holes for these pins in line with each other, and also to have them square with the punch and die, the following method was used: After the punch and die were hardened and assembled, two parallels were placed between the bolsters. The punch was placed inside the die and the punch and die clamped together with four C-clamps. After the work had been clamped in this way the holes were bored in the punch-holder through the holes in the die-bolster, and were consequently in perfect alignment.

Fig. 6 shows plan and sectional views of the blanking and piercing punches *A* and *B*, which are made of tool steel and left soft. These punches are secured to the cast-iron holder *C* by means of two fillister screws and two dowel-pins. In order to locate the punches in proper alignment with the die, the punches are first marked so that they can be replaced in the same positions. The ejectors are then taken out of the die, and blocks made of  $\frac{3}{4}$ -inch cold-rolled steel are placed in the die holes in their places. These parallel blocks are faced off to the proper height to bring them  $\frac{1}{16}$  inch below the cutting edge, all six of the blocks being of the same height. The punches are next placed in their respective die holes and the punch-holder *C* is then slipped over the four sub-press pins in the die-bolster and lowered onto the punches. With a right-angle scratch-awl, lines are marked on the punch-holder to locate the four sides of each punch, the scribe being worked through the screw holes in the die-bolster. The punch-holder is next withdrawn, and from the outlines of the punches on the holder the four holes for each punch are located, drilled, and counterbored to receive the two set-screws and the two dowel-pins. When all of these holes are drilled in the holder, the latter is once more replaced on the punches and secured with four C-clamps. Care must be taken not to twist the punches and also to see that the two bolsters are parallel with each other. All of the screw and dowel-pin

holes are now drilled into the punches to a depth of about  $\frac{1}{32}$  inch, the holes in the punch-holder serving as a guide. The C-clamps are now loosened and the punch-holder removed; all of the punches are then taken out of the die and the holes are drilled to the required depth, after which the screw holes are tapped. When this work has been finished, the punches are replaced in their respective positions on top of the blocks in the die. Care must be taken to have all the chips removed and the work perfectly clean. The punches are secured with screws and the two bolsters again strapped together with four C-clamps; straight dowel-pin holes are then reamed through the bolster into the punches. In this way all of the punches and sub-pressure pins are in perfect alignment.

Pilots *D* are screwed on top of the three blanking punches to guide the metal during the blanking operation. These pilots enter the holes in the washers which were pierced by the preceding stroke of the ram, and prevent the work from twisting. The pilots are held in place by a screw and a dowel-pin. A stripper plate *E* made of  $\frac{5}{16}$ -inch cold-rolled steel surrounds the punches and is held in position by the tension of fifteen springs. This stripper plate is made to fit between the guides *I* (Fig. 4) on the die and is a free fit on the outside of the punches. The stripper plate is adjusted by the flat-headed screws and nuts *F*. It will be noticed that there is a small hole in the center of each spiral spring seat. These holes are made in the following manner: All of the holes in the stripper plate are laid out in the usual way and drilled through with a  $\frac{1}{8}$ -inch drill; the stripper is then placed on the bolster with all of the punches in position and the holes are transferred through onto the bolster. The spring seats can now be counterbored on the stripper and bolster and by this means all of the spring seats will be in perfect alignment with each other.

**Sectional Die for Linotype Type-bar Plates.**—A punch and die for producing the type-bar plates for linotype machines is illustrated in Fig. 7. These plates have one hundred rectangular holes 0.060 by 0.360 inch in size, and the bar is 0.03 inch thick. One of these plates is attached to the under side of each linotype



machine for holding the end springs which return the type bars after the keys are struck by the operator. It is necessary to have these type-bar plates made with considerable accuracy; the holes must be of the size specified, there must be the proper space between them, and their sides must be parallel and perpendicular, respectively, with the edges of the plate. Evidently these conditions would make it very difficult, if not impossible, to produce plates of this type with a single punch and die and a suitable form of spacing mechanism.

Several attempts were made to produce a punch and die for this purpose before a successful device was hit upon. In the first case, the punch and die appeared to be satisfactory after it was finished, but had only run a few days when one of the bridges caved in to such an extent that attempts to repair it were unsuccessful. The second punch and die was of similar design to the first, except that special means were taken to strengthen its construction. When this die was inspected after hardening, however, it was found that two of the bridges were cracked in the corners. It was then decided to make a sectional form of punch and die which would enable individual parts to be replaced when broken or worn in service, without necessitating the construction of an entirely new tool. The die section adopted for this purpose is indicated at *B* in Fig. 9. It will be seen that two  $\frac{5}{16}$ -inch holes are drilled and reamed through these sections, pieces of drill rod being used to hold the sections together in a 30-degree bolster; the sections were wedged in this bolster by means of a suitable gib and set-screws. This die also proved a failure because no provision had been made for guide-posts or pilots. The result of this omission caused the die to shift while in service, so that the punches were stripped to such an extent that they became absolutely useless. The difficulties met with in early forms of dies for producing these type-bar plates are mentioned in order that the same trouble may be avoided by other shops that are called upon to produce punches and dies of this type for similar classes of work.

Fig. 7 represents the form of sectional die which was finally developed for this operation. All parts of this tool which are

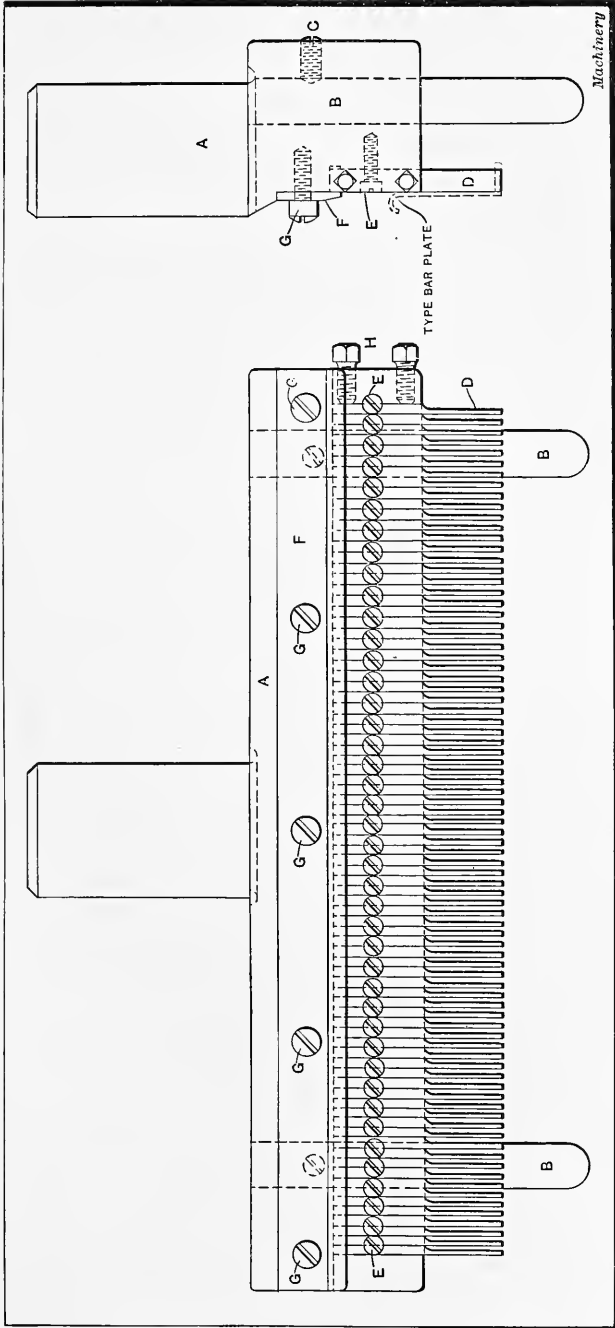

Fig. 8. Side and End Elevations of Sectional Punch

likely to be worn or damaged in operation are made interchangeable, duplicate parts being kept in stock so that they can be placed in service when required. The die pieces are machined to the required dimensions, allowing 0.005 inch for grinding and lapping. One of the die sections *C* is shown in Fig. 9. In order to machine these parts so that the slot would be the same distance from the inclined sides of the bolster, the milling fixture (also illustrated in Fig. 9) was designed for producing them. The cast-iron block of this fixture is held in an ordinary milling machine vise and the pins *E* and *F* are so placed that the blank for the die sections will be held at an angle of 60 degrees. The strap *G* holds the work in position while milling; all of the pieces are first milled at one end to an angle of 30 degrees, after which they are turned over in the fixture to have their opposite ends milled in a similar manner. Before starting the section milling operation, the machine is set to produce pieces of the required length, and it will be evident that this method of production insures having all the die sections of exactly the same size. The same fixture is used for milling the slot in the die section; for this purpose the fixture is swung around 30 degrees and a cutter 0.360 inch wide is used, the slot being cut 0.060 inch deep. The three sides of the slot are now relieved with a file and after being hardened and drawn to a light straw color, the sections are ground on both sides so that the section through the slot will just enter the 0.060-inch space in the gage *H*, and the thicker section will enter the 0.120-inch space. The bottom and angles are not ground, but the tops of all the sections are ground when they are assembled in the cast-iron bolster *I*, Fig. 7. Two set-screws *J* are provided to take care of the end-thrust on the die sections. The length of the die is 9 inches, but if it is found that this dimension is slightly exceeded, it is an easy matter to lap the sections off on the sides to reduce it the required amount.

The cast-iron bolster is held securely to the press bed by means of four  $\frac{5}{8}$ -inch hexagon screws. The gib *K* runs through the entire length of the die-bolster and is held against the die sections by four set-screws *L*. On top of the bolster, there are



two soft-iron plates *M* and *N*. The plate *M* is held in position by five fillister screws and acts as a stop-wall for the work to rest against in the die. This plate has slots milled along its edge which correspond with the die section, only they are a few thousandths larger than the punches; the plate *M* also acts as the stripper for the punch. The plate *N* slides back and forth on the bolster under the strap *P*, its movement being controlled by the cam and lever *S*. The hardened wedge *R* is driven into the middle of the plate for the cam *S* to rest against and when the cam is swung around to bring the flat section into engagement, the springs *Q* at each end of the die pull the plate *N* back so that sufficient space is made to lift the finished work out of the die.

There are two  $\frac{3}{4}$ -inch holes *O* provided in the bolster to receive the pilots *B* of the punchholder, Fig. 8. These holes have hardened bushings driven into them which can be replaced when they become worn to an objectionable extent. The punch sections are held in a machinery steel holder *A* shown in Fig. 8. This holder is finished all over, great care being taken

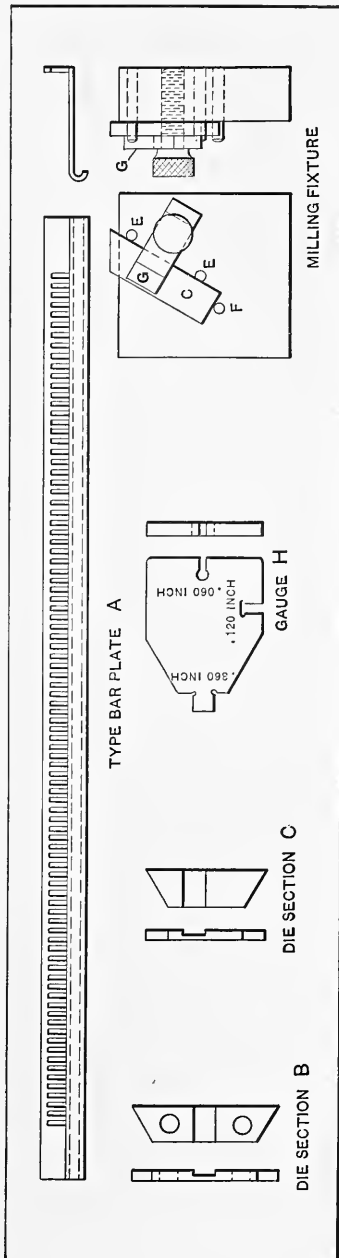

Fig. 9. Type-bar Plate A; Die Sections B and C; Gauge H; and Milling Fixture for Making Die Sections

to secure the necessary alignment. The guide pins *B* are hardened, ground, and lapped to exact dimensions and the same gage *H* (Fig. 9) that was used for measuring the die sections is also used in determining the accuracy of the punch sections. These punch sections are secured to the holder by fillister screws *E*, a single screw being used between two sections in the manner shown in the illustration. The clamp *F* runs the entire length of the holder and is held in position by the fillister screws *G*. Two set-screws *H* are provided to take up any end-thrust in the punch sections.

It may appear that this punch and die is rather complicated, but this design seemed to be the only one that could be maintained in working condition; moreover the working parts are relatively simple, and were not as expensive to make as it might appear. The forming of the type-bar plates *A* (Fig. 9) is done in two operations. The stock is rolled on a spool and held in the proper position to be received by a powerful trimming press. In the first operation, the stock is cut off and formed to the right angle; the downward stroke of a roller at the back of the die then curves the other edge of the plate upward to form a quarter segment. The second operation is done separately in a clamping die and forms the plate to the required shape.

**Making Sectional Die Parts.** — The making of sectional dies for armature disks and work of a similar kind calls for considerable ingenuity on the part of the toolmaker in devising means for producing these parts accurately and economically. It is necessary, if the best results are to be obtained, to secure a steel which will not warp or distort during the hardening process so that grinding of the parts after hardening may not be necessary. Should the die and punch sections warp or shrink, it adds greatly to the difficulty of manufacturing the parts and greatly increases the cost of the tool. In many cases grinding of the die and punch sections is necessary, so that special devices and tools have been devised for handling this work as expeditiously as possible. In the following, a number of the most interesting methods employed by the Columbus Die, Tool & Machine Co. will be given.

**Grinding the Die Sections.** — In order that the die sections will fit properly in place after hardening and give the required outside and inside diameters, it is necessary to leave a slight amount of excess stock on the sides of the sections that fit against each other in the die-holder. These sides are then ground to the required angle and thickness in a special fixture. The toolmaker figures out the required angle of the side sections and also the least or greatest thickness. The type of fixture used for grinding these die sections for armature disk dies is

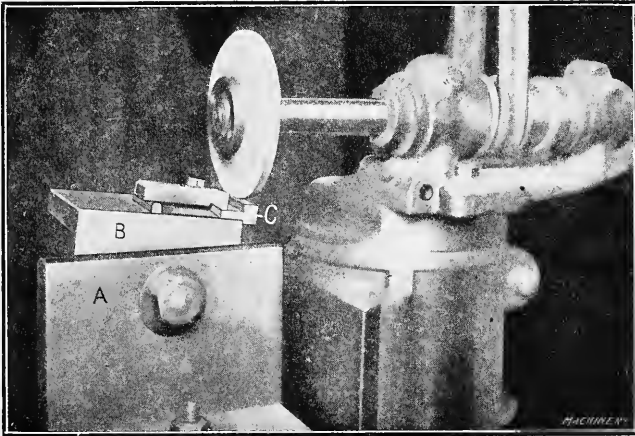

Fig. 10. Grinding Die Sections

shown in Fig. 10. It consists of an ordinary angle-plate *A* which is fastened to the table of a grinder of the surface type, and against which is held another angle-plate *B* that can be set around to the desired angle and carries the work to be ground. The work or die section *C* in this case is held in place by a special toe clamp, and when one side of the section is ground it is reversed and the other side is ground.

The sides of the punch sections are ground in a similar manner on the same fixture which, however, is swung around into the position shown in Fig. 11. The punch section *A* is held to the small angle-plate *B* as illustrated, and when one side is ground the section is reversed on the angle-plate and the other side finished. When the fixture has once been set up, however, all the punch or die sections are ground on one side first. Then

the setting of the machine is changed and the other side of all the sections ground. This enables the toolmaker to turn out the work much more quickly than if he were to reset the machine for both sides of the piece, thus finishing it complete without removing it from the fixture to put another in its place.

**Special Chucks for Holding Die and Punch Sections.**—In Fig. 12 are shown two special chucks which are used for holding punch and die sections while grinding the inside and outside

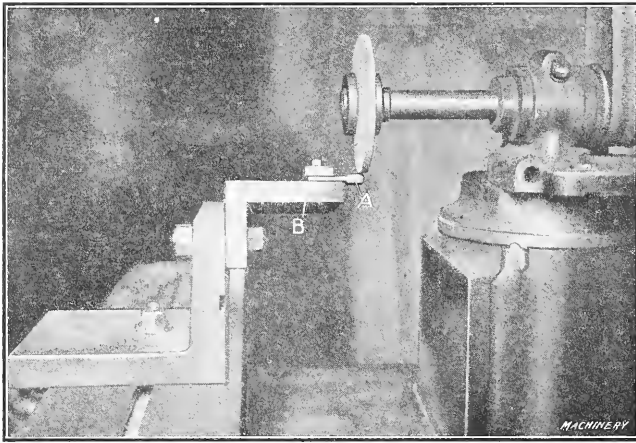

Fig. 11. Grinding Punch Sections

diameters and the top and bottom faces, so that all the important machined surfaces can be finished at the same setting. The special chuck for holding the punch sections is shown to the right of the illustration. This, as can be clearly seen, consists of a cup-shaped body *A* around the periphery of which are located set-screws *B*. These set-screws bear against the backs of the sections and bind them together, the beveled surfaces of the punch sections being wedged together by the action of the set-screws, and consequently held rigidly in place for the grinding operation. The grinding is done in a cylindrical grinding machine, the chuck being screwed to the nose of the spindle in the ordinary manner. The outside surfaces are ground tapered to an angle of 5 degrees to enable them to be held in place in the punch-holder by a retaining ring.

The special chuck for holding the die sections for grinding is shown to the left of the illustration. Here only four die sections *C* are shown in place, simply to indicate the manner in which they are held. The narrow portion of the die section is a drive

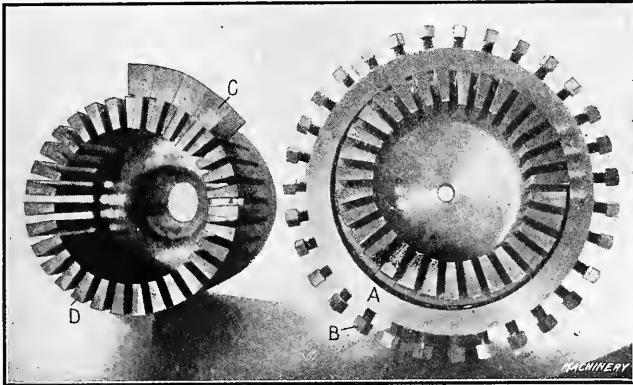

Fig. 12. Special Chucks for Holding Die and Punch Sections while Grinding

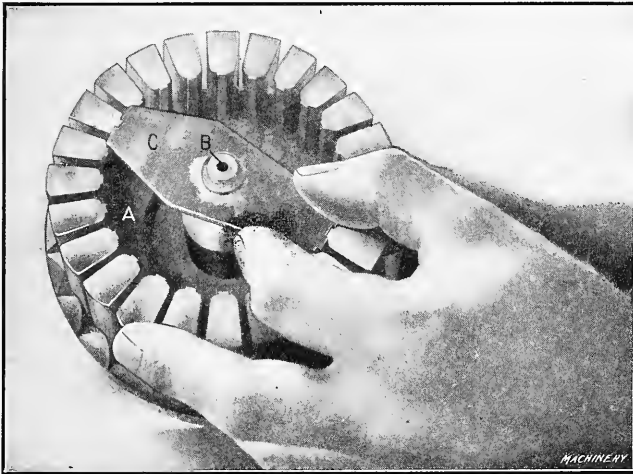

Fig. 13. Assembling a Sectional Armature Disk Punch

fit in the slots of the die-holder and these sections are tapped lightly into place until the beveled surfaces contact. The chuck *D* is also held in a cylindrical grinder, being screwed to the nose of the spindle as previously mentioned in connection

with the chuck for the punches. This chuck enables the inside and outside diameters of the die sections to be ground and also the top face. The lower face is ground by reversing the position

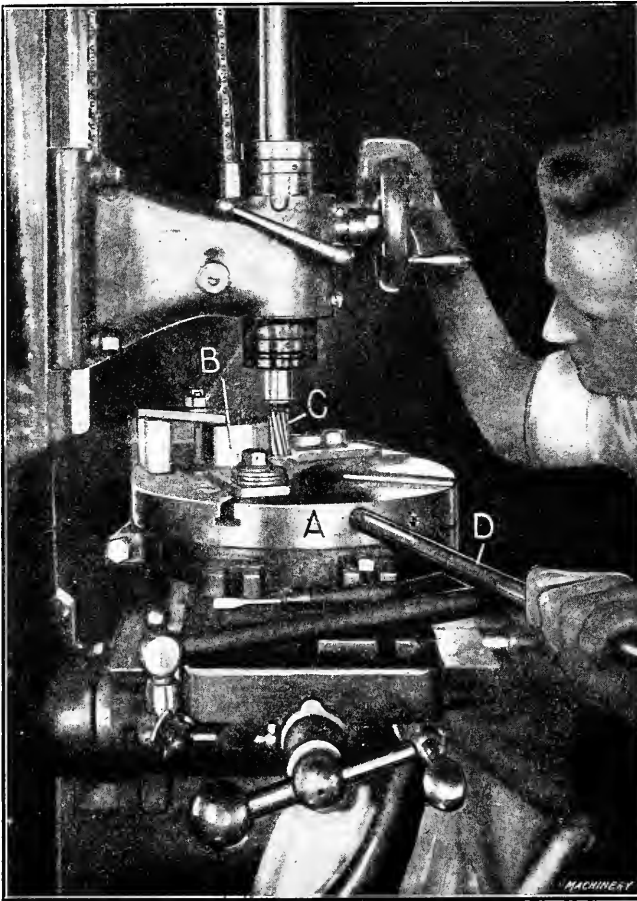

Fig. 14. Milling Segments for Pole-piece Punch

of these sections in the chuck, and then holding them in the manner in which they are held in the illustration.

**Assembling an Armature Disk Punch.** — After the beveled sides of the punch sections have been ground, as previously described, it is then necessary to test these sections to see whether the correct inside and outside diameters have been secured, and

also if the small projections on the inner surfaces of the punch sections are properly located axially. This, of course, proves whether the correct amount of stock has been ground from the sides of the punch sections. The fixture used for this purpose is shown in Fig. 13 and consists of a block *A*, circular in shape, in which a stud *B* is located. This stud acts as a means for holding the gage *C*, which, as can be seen, is cut to fit over the projections on the punch sections and is also fitted over the stud, being centrally located in this manner. In this particular

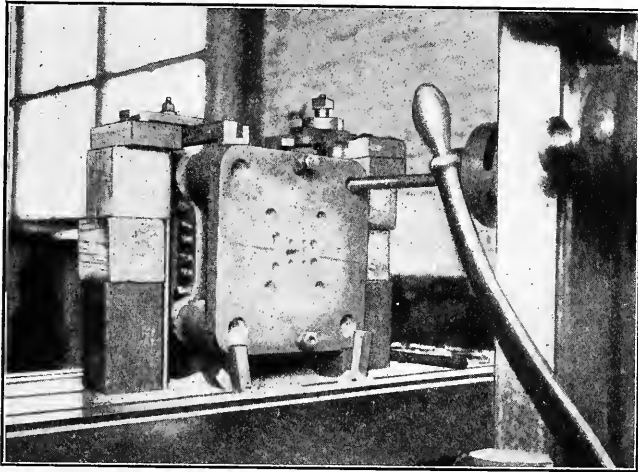

Fig. 15. Boring Sub-press Die Guide-pin Holes

case, a limit of only 0.0005 inch is allowed from the center of the plug to the inside face of the punch section. Also the blank must be reversible on the punch. When it is realized that these dimensions are governed entirely by the amount of metal removed from the sides of the sections, it will be seen that the grinding operation is one that must be very carefully handled and that requires considerable ingenuity on the part of the tool-maker if the parts are to assemble accurately.

**Milling Segments for Pole-piece Sectional Punches.** — Fig. 14 shows how segments for pole-piece sectional punches are milled both on their circular and angular faces. A Knight milling and drilling machine is used for this purpose, being equipped with a circular milling attachment *A*. The section *B*

of the pole-piece punch to be machined is clamped to the top face of the circular milling attachment by clamps as illustrated, and the machining is accomplished by an end-mill *C* held in the spindle of the machine. The circular attachment is operated by a bar *D* which can be located in holes provided around the periphery of the faceplate. For milling the beveled faces, the circular attachment is clamped to prevent it from rotating and the feed-screw for the table is operated.

**Boring Sub-Press Die Guide-pin Holes.** — After all the various members of the sectional punch and die have been completed, they are assembled in the punch- and die-holders and then the next operation is to bore the holes for the aligning pins, when the dies are of the sub-press construction, which is the usual type of construction adopted for complicated sectional punches and dies. The manner in which these guide-pin holes are machined is shown in Fig. 15. The punch- and die-holder are located in the proper relation to each other and are fastened together by through bolts as illustrated. Then these holders for the sectional members are located on the table of a milling machine and the holes are first drilled and then bored by a boring tool held in the spindle of the machine. The two lower holes are bored and counterbored first, the center distances, of course, being located by the micrometer dial on the feed-screw. Then the table is lowered and the top or two remaining holes are bored and counterbored in a similar manner. This method of boring the guide-pin holes enables them to be produced quickly and accurately with very little difficulty.



## CHAPTER VII

### AUTOMATIC FEEDING AND EJECTING MECHANISMS FOR PRESSES

Power presses for producing articles made from sheet metal are equipped with many devices for automatically feeding the strips of flat stock or blanks to the dies. In addition to the economy of a more rapid production, the application of automatic feeds to power presses assists in protecting the hands of the operator, because the automatic feeding mechanism makes it unnecessary for him to put his hands near the dies. Various forms of feeding mechanisms are applied to presses of every type, the kind of feed used depending upon the material to be handled. The types of automatic feeding mechanisms most generally employed are the single and double roll, grip, gravity, push, dial, and reciprocating feeds. There are numerous ways of applying these types of feeds to power presses in order to adapt them to the specific requirements. Frequently feeds of two types are combined to facilitate production. Some feeds are entirely automatic, the operator having only to keep the machines constantly supplied with the metal from which the punchings are made; however, on dial and other feeds which only automatically carry the work forward, under and away from the dies — especially on riveting, assembling, clinching, and forming operations on pieces previously blanked or cut out in another press — an operator is required to feed each separate piece into the feeding mechanism which then carries the work to the dies.

**Single-roll Feed.** — In Fig. 1 is illustrated a single-roll feed fitted, in this case, to a straight-sided press. This type of feed is used for feeding strip stock, but the particular feeding device illustrated is not built in the regular manner, as the work for which it is used requires a very accurate feed — more accurate

than could be obtained with the regular size of standard single-pawl feed. The difference in construction from the regular feed is in the ratchet *A*, which is operated by three pawls held to a segment disk *B*. This feature reduces the inaccuracy in feeding to a minimum without the use of a ratchet three times the circumference of the single pawl ratchet, which would be necessary to obtain the same result with the ordinary type of feed.

This ratchet feed can be adjusted for a wide range of length of feeds, the adjustment being made by means of an adjusting

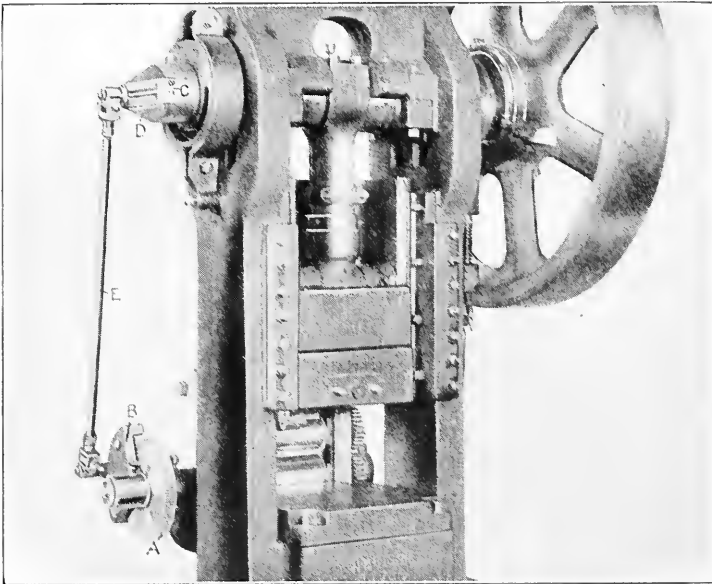

Fig. 1. Straight-sided Press Equipped with Single-roll Ratchet Feed

screw in the block *C*, held in the eccentric arm on the end of the crankshaft. Power is transmitted from the eccentric arm *D* to the roll shafts through the ratchet *A* and pawls, the connecting-rod *E* being fitted with universal joints. The roll shafts are connected by gears, as shown, and to avoid over-feeding, due to the momentum of the feeding parts, the lower roller shaft is fitted with a brake. The feeding device in this case is situated at the rear of the press, but it can also be arranged either in front or to the right- or left-hand sides, as desired.

Another type of single-roll feed, fitted to an inclinable press, is shown in Fig. 2. This feed differs from the one shown in Fig. 1 in the method of driving, the rack type of drive being used instead of the ratchet type. The rack type of drive is largely used for long feeding, as it gives a wider range of feed, with the same sized rolls, than can be obtained with the ratchet feed. It is not advisable to feed over 90 degrees, or one-quarter turn of the rolls, with a ratchet feed, but with the rack feed

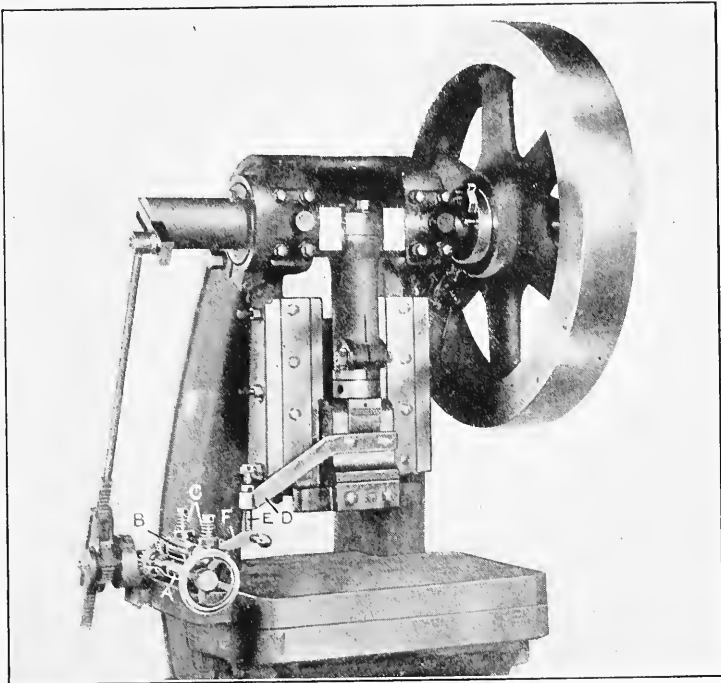

Fig. 2. Inclinable Press having a Rack-operated Roll Feed

several revolutions of the feed rolls can be made for one stroke of the press. This permits the use of small feed rolls, making a smaller and more compact attachment.

**Automatic Release for Feed Rolls.** — The feed rolls shown in Figs. 1 and 2 are provided with an automatic release, this being more clearly shown in Fig. 2. This automatic release of the rolls is necessary when pilots are used in the punches. The operation of the automatic roll release is as follows:

Referring to Fig. 2, the feed rolls *A* and *B* are held in contact by means of springs *C*. The lower bearing in which the roll *A* is held, is stationary, while the upper bearing carrying roll *B* is movable. The releasing device consists mainly of a bar *D*, attached to the ram of the press, in one end of which is a set-screw *E*. The point of this set-screw bears on an arm

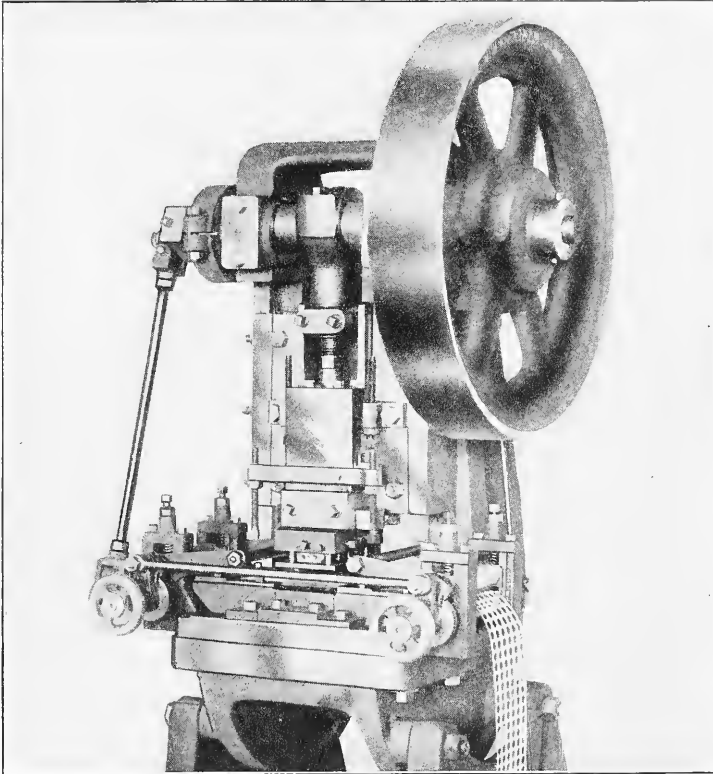

Fig. 3. Press Equipped with Double-roll Feed

*F* which is cast integral with the top roll bracket. As the ram of the press descends, the screw *E* comes in contact with the arm *F*, releasing the stock when the pilots in the punches enter the die. The stock is then free so that it can readily be shifted by the pilots if necessary. It will be noticed that the roll release arm *F* is provided with a handle so that the upper roll can be released by hand when starting a new strip.

**Double-roll Feeding Attachment.** — Fig. 3 shows what is termed a double-roll feed attached to an open-back inclinable power press. The press, when in use, is set on an incline, thus permitting the cut and formed work to automatically fall away from the dies by gravity. This style of feed is applicable to almost any type of press but, like most other feed mechanisms, it is adapted only to work produced from a flat sheet or coil, either with plain blanking or cutting dies or with combination cutting

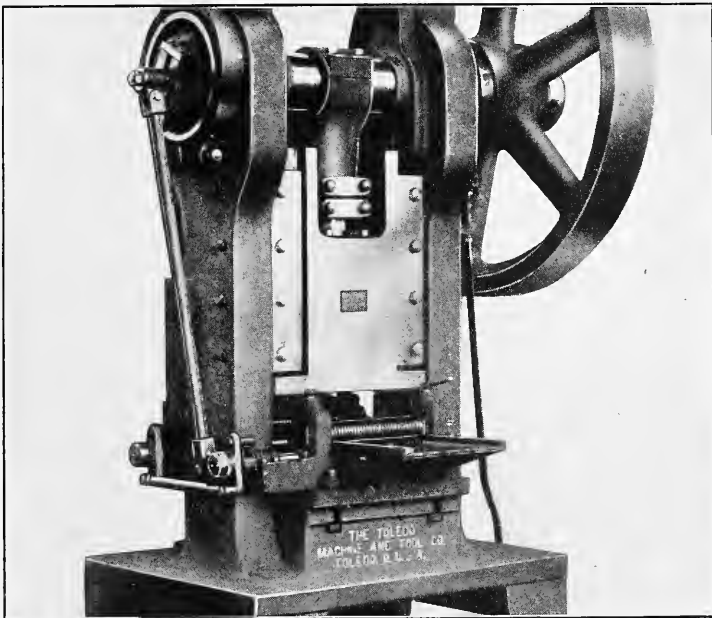

Fig. 4. Double-roll Feeding Mechanism applied to Straight-sided Press

and forming dies. Roll feeds consist of rolls of varying diameter and length, with a variable “feed-stroke,” and while they insure accurate feeding and a saving in material, their actual value to each individual manufacturer depends primarily upon the size and shape of the article made, the construction of the dies, and whether single or gang dies are used.

The feeding device attached to the press in Fig. 3 is adjustable by sixteenths for feeding up to  $1\frac{1}{2}$  inch at each stroke of the press. The journals or boxes for supporting the rolls are

adjustable to accommodate varying gages of metal. Pivoted releasing-levers or arms, bearing upward against powerful springs in each of the journals supporting the upper rolls, extend inwardly and under adjustable set-screws attached to the slide or ram of the press. Depending upon the manner in which they are attached, these roll feeding devices can be arranged to feed the stock from front to back or *vice versa*, or from right to left or *vice versa*. The stock is fed forward on the up-stroke or return of the shaft and slide, and as the slide descends, the set-screws mentioned, bearing down on the pivoted releasing-arms, lift up the upper rolls momentarily, releasing the pressure upon the strip of metal, so that, in the event of any unevenness in the thickness of the metal or any variation in the feeding, a pilot or guide pin on the dies may locate the strip before the dies actually perform their work.

Fig. 4 shows a special double-roll feeding mechanism operating on a straight-sided press equipped with gang dies for performing various operations on strip steel for expanded metal lath. The stock is fed into the machine in flat strips previously cut to the proper width. The first or forward set of rolls has a series of milled V-grooves for ribbing the flat ribs longitudinally as they are fed into the machine. Passing from this first set of rolls into the dies, the strip is gradually slitted and expanded, and then automatically discharged by the rear set of rolls; the latter have, besides the V-grooves, a series of slots cut in them to match the shape of the stock that is slitted. This feeding device is adjustable for feeding up to 2 inches at each stroke of the press, the machine operating at 250 R.P.M.

**Rack-and-pinion Double-roll Feed.** — In Fig. 5 is shown a small open-back inclinable press fitted with another special double-roll feeding mechanism. In this case, instead of having the eccentric or feeding arm connecting the cam on the shaft directly with the rolls, the drive is imparted from an eccentric on the shaft to a vertical-traveling rack, which, through its pinion and a series of bevel gears and an endless chain, acts as the drive for the rolls. This construction is what is termed a "rack-and-pinion" feed, and is resorted to in many cases where

the work is of such a nature that it is desired to have the front of the press as open and free from arms as possible, to insure complete accessibility to the dies and work. This is the prime reason for the use of this construction in this instance. The purpose of the press is the cutting out of corn plasters. The

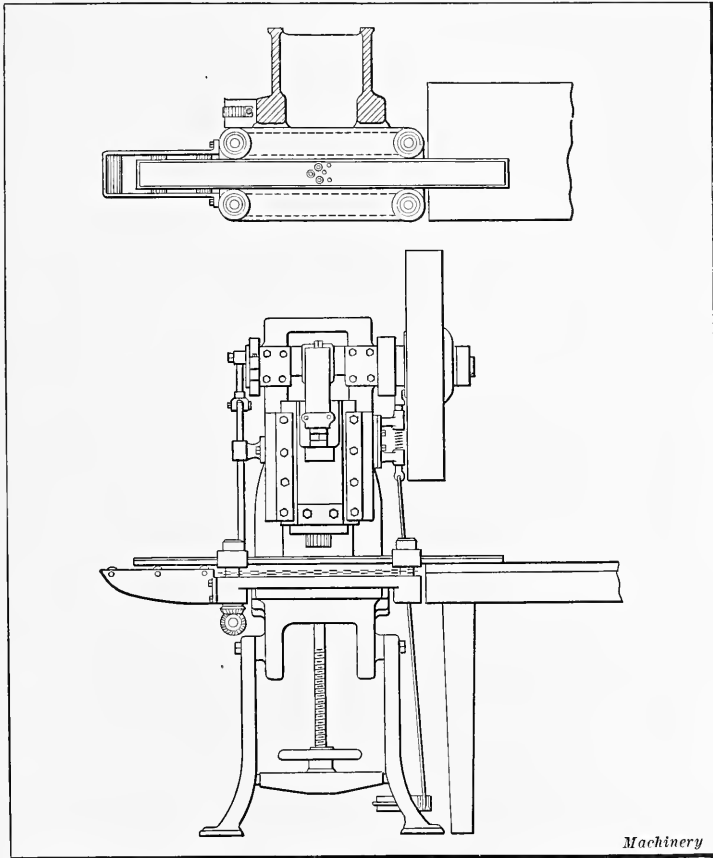

Fig. 5. Press Equipped with Rack-and-pinion Double-roll Feed

medicated cloth for the plasters, in strips about 4 inches wide and 48 inches long, is fed into the machine on a hard maple board of a slightly greater length and width, the board being fed forward about  $1\frac{3}{4}$  inch at each stroke of the press. The work is performed by a group of hollow punches of the same

construction as those regularly employed for cutting cloth, paper and other fibrous materials. The first set of three punches cuts out only the center or "corn" opening, while, at the following stroke of the press, as the stock is fed forward, the second set of three punches cuts out the completed cloth ring for the plaster. The punches for cutting the center opening are so constructed that the cloth is pushed up into them, and gradually automatically ejected through an opening in the back of the slide or

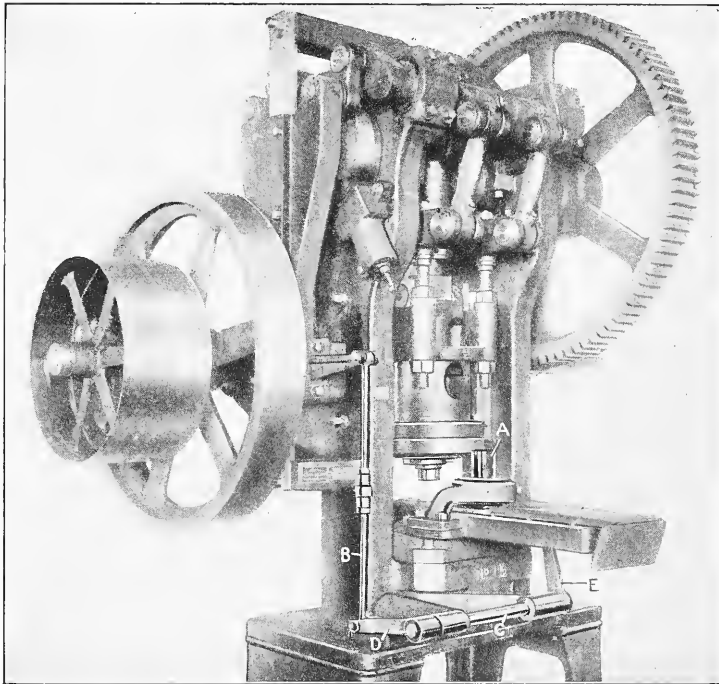

Fig. 6. Toggle Drawing Press having Push Feed and Magazine

ram to which the punches are attached. After the second operation the cut disks or rings are removed or stripped from the punches (or, more literally speaking, cutting dies); they are left on the maple board and taken back to the work-bench where the simpler operations are performed by hand to finish the plaster. In the meantime another board with its strip has been fed into the machine. The machine operates at 100 R.P.M., producing 300 rings per minute.



**Push Feed.** — The toggle drawing press shown in Fig. 6 is provided with a push feed, the operation of which is simple. The flat blanks (which have previously been cut out) are placed in the magazine *A*, from which they are removed one at a time to the dies, the feeding being accomplished by a traversing slide receiving its motion through rods *B* and *C*, and levers *D* and *E*.

**Slide Feeds.** — The feed mechanism attached to the small press in Fig. 7 is designed for use in connection with parts requiring forming operations, which, owing to the irregular shape of the pieces, make hand feeding necessary. Even experienced operators are at times careless in feeding or removing the work and also in starting the press. The slide feed shown eliminates accidents from such causes, as the only time that the operator's hands are near the dies is after the operation has been completed, the press stopped, and the dies returned to the front of the press for the removal of the finished piece and the insertion of another. After placing the piece in the dies and "tripping" or starting the press, the dies are automatically carried back to their proper position under the forming punch by means of the toggle-arms connected to the cam and eccentric collar on the end of the shaft. This cam provides not only a positive, quick feed, but also a quick return of the dies to the front of the press after the work is finished. This style of feed is extensively employed in connection with the manufacture of small odd-shaped automobile radiator tubing, bottle caps, jewelry, and gas fixtures.

**Ratchet Dial Feeds.** — Fig. 8 illustrates what is designated as a dial or rotating feed, because of the fact that the work is automatically carried forward to and away from the dies by a continually revolving dial or feeding-table. This table is operated by a pawl and ratchet connected with an eccentric attached to the shaft of the press. The feeding dials are provided with holes varying in number according to the size and shape of the work and the size of the bed of the press to which the feed is fitted. Into each of these holes is fitted a tool-steel bushing or chuck with a milled opening to match the shape of the piece to be operated upon. These bushings are removable, a different

set of bushings being required for each shape or size of piece. To prevent the pieces from dropping through these openings in the bushings until the dial brings them to the dies, a stationary cast-iron plate is bolted onto the bolster or bed-plate of the press, directly beneath the revolving dial. This plate has openings to correspond only to the dies used. In some cases the cut pieces, ready to be formed, are automatically fed into the dial or rotating plate by a hopper or tube rigidly secured to the press

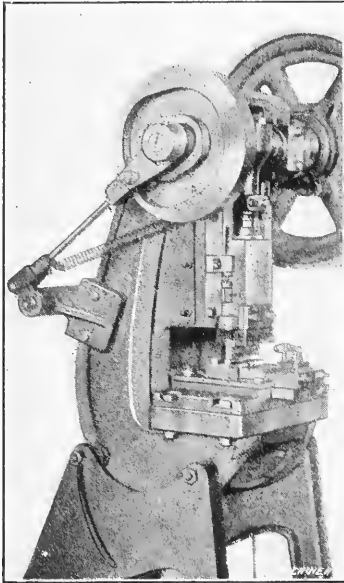

Fig. 7. Press Equipped with Slide Feed Mechanism

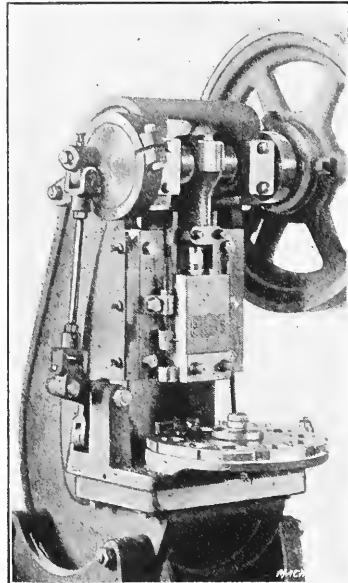

Fig. 8. Ratchet Dial or Rotating Feed Mechanism

bed. This, however, is feasible only on circular, square, or other regular shaped blanks. Irregular shaped blanks must in almost all cases be fed into the dial by hand, and as speed is the principal reason for the employment of this style of feed, it should be so arranged as to leave the front or feeding end of the press and feeding-table as accessible as possible for the operation. This is the distinctive feature of the dial-feeding mechanism shown in Fig. 8.

Dial-fed presses are widely used by manufacturers of curtain brackets, cartridges, locks, hardware stampings, and, in general,

for articles requiring several forming operations, the dial-feeding mechanism permitting the use of dies for performing from one to four successive operations on certain classes of stampings in one press. One western telephone manufacturer uses one press fitted with a double-roll feed and ten other presses fitted with dial feeds for performing twenty-nine operations on a single stamping of light gage steel and of a very irregular shape. The dial-fed press shown in Fig. 8 is also fitted with an automatic bottom "lift-out" (not shown) for ejecting the finished stampings from the dies, and with an automatic safety device

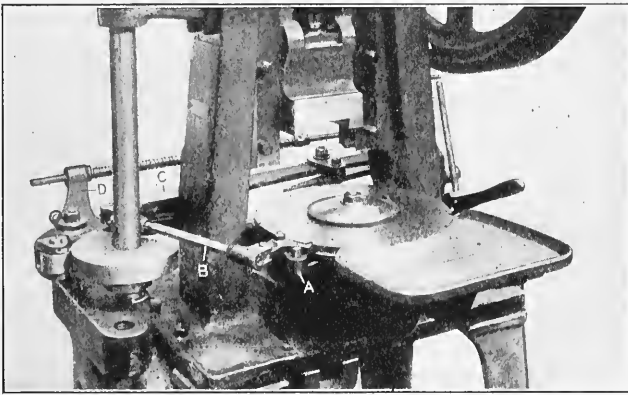

Fig. 9. Front View of a Dial Feed Operating Mechanism

attached to the trip-lever for the clutch, which automatically stops the press if the dial is not properly fed forward.

Presses equipped with the ratchet dial feed are generally provided with a safety device. This device is so connected with the clutch used in stopping and starting the machine, as to stop the ram on its downward stroke before it can do any harm, if it should so happen that the dial is prevented from assuming its correct relative position. A safety device of this kind is applied to the dial feed described in the following.

Another design of ratchet dial-feeding mechanism is illustrated in Figs. 9 and 10 which show front and rear views of the mechanism which controls the operation of the dial. Referring to these illustrations, it will be seen that the pawl is mounted on an arm *A* which causes it to move in a circle concentric with the dial.

The link *B* is connected to the end of the pawl which is shaped like a bellcrank, and there is a stop on the arm *A* which limits the motion of the pawl. The link *B* is operated by the arm *C*, which is pivoted at a point behind the right-hand upright of the press; this arm is, in turn, operated by the roll arm *D*, the two members being connected by an adjustable sliding block which may be regulated for the use of any number of notches in the dial from 12 to 24. The pawl, together with the complete dial driving mechanism, is returned by a spring which is located in such a way that it acts on both the levers *C* and *D*, eliminating lost motion from the mechanism.

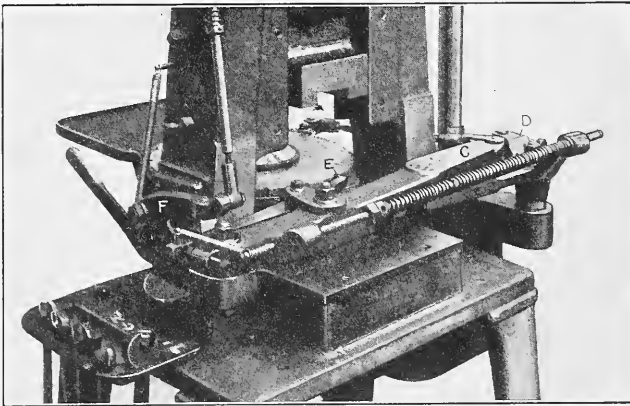

Fig. 10. Rear View of Dial Feed Operating Mechanism

The timing of the dial operating cam, which, as shown, is mounted on a side shaft and driven from the left-hand end of the crankshaft by bevel gears, is such that the dial starts to move forward when the ram is half way up and the indexing of the dial is completed at or before the time when the ram reaches the highest point of its stroke. The cam holds the pawl and dial in this position until the ram has practically reached the lowest point of its stroke, and by this time the tools have entered the dial so that, before the pawl releases it, all possibility of its shifting out of place has been eliminated. When the pawl starts to move back, the first part of the motion consists of lifting the pawl out of the dial notch, this motion being limited by the stop in the lever *A*. The lever *A* is then carried

back until the pawl has been brought into position to enter the next notch in the dial. During this time, the ram has moved up and if, through the breaking of any part or from some other unusual condition, the dial is not indexed to the right place, the locking lever *E*, which is mounted on the lever *C*, will not enter the slot in the dial, and as a result, the opposite end of the lever *E* will engage the stop on lever *F*, thus holding this lever up and making it impossible to engage the clutch for the next stroke of the press. The arrangement of this mechanism is clearly shown in Fig. 10.

In running a dial press, it sometimes happens that the knockout will fail to bring the work out of the die or that the bottom of a shell will be torn out in drawing it through the die, thus leaving a shell between the die and the dial. To avoid a serious accident in the event of an occurrence of this kind, the link *B* is so designed that it will be bent or broken before any other part of the press gives way, and as this link is simply a piece of cold-rolled stock, an accident of this kind is not serious. The clutch furnished on these machines is of the standard key type and the knockout is operated from cams carried on an under motion shaft, the cams acting directly on the end of a straight knockout rod.

**Friction Dial Feed.** — This type of feed mechanism has a plain disk which revolves continuously, instead of having an intermittent motion like the ratchet dial feed. The disk is used in combination with stationary guides and gages above it, so that the work placed on the revolving disk is accurately carried around under the punch. In order to insure reliable action, a finger or gripping mechanism is usually provided which locates and holds the work in the right position for the descending punch. The friction dial feed is adapted for re-drawing short shells or parts which are not liable to topple over.

**Friction Dial and Push Feeds.** — In Fig. 11 is shown an inclinable power press to which is fitted an automatic friction dial and also a push feed. This press is used for reducing and stamping shells which have been previously cut out and drawn in another press. In operation, the shells are placed on the table *A*

from which they are removed to the revolving dial *B*, the top of which is flush with the table. The dial *B* carries the blanks to an automatic stop from which they are released one at a time by the cam and spring-actuated feed-arm *C*, carrying them to the dies. The arm *C*, which is pivoted to the bracket *D*, is actuated by a cam *E* on the vertical shaft *F*. This shaft derives its power through the bevel gears shown, one of which is attached to the end of the crankshaft. From the vertical shaft

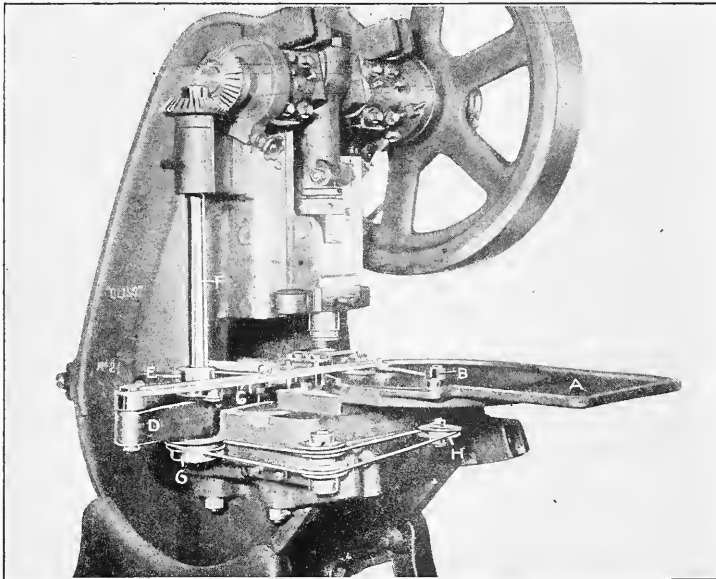

Fig. 11. Press Equipped with Combination Friction-dial and Push Feed

*F*, power is also obtained to drive the revolving dial *B* through pulleys *G* and *H*, by a round belt running over suitable idlers.

Another feature of this press which might well be mentioned, but which in a measure could not be considered a feed, is the method used in removing the finished blanks. This is accomplished by means of a continuous operating endless belt fitted between the sides of the press and driven by a belt running over the hub of the flywheel. After the first blank has been fed to the dies and operated upon, the blank following it is carried to the die by means of the feed-arm which pushes the

first blank off the die onto the conveyor, the latter depositing the blank in a suitable receptacle.

**Friction Dial and Reciprocating Feed.** — A combination automatic friction dial and reciprocating feed fitted to an inclined press is shown in Fig. 12. Three operations are performed simultaneously by this press. Presses fitted with this combination of feeds are particularly adapted for the production of pieces on which there is a series of operations. The shell to be oper-

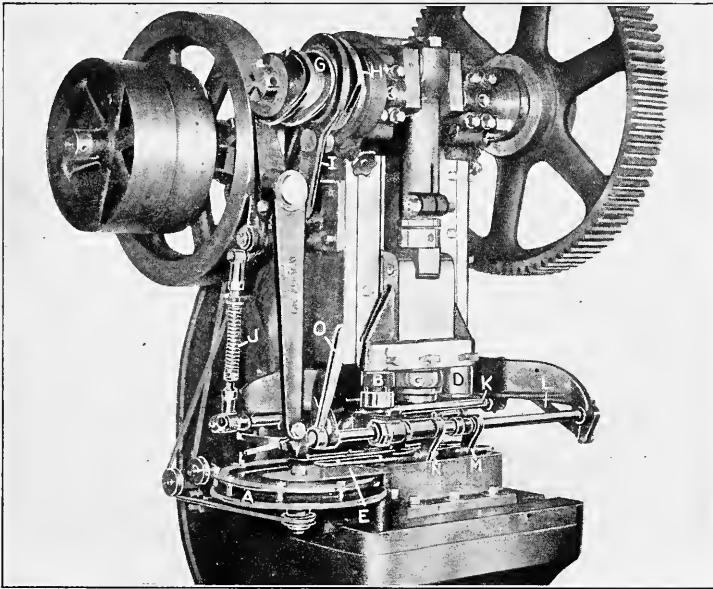

Fig. 12. Press having a Combination Friction-dial and Reciprocating Feed

ated upon in this press is previously cut out and drawn in another press fitted with a feed similar to that illustrated in Fig. 11. After the shells have been blanked and drawn they are placed on the continuously revolving dial *A* which carries them up to an automatic stop from which they are released one at a time. Here they are gripped by the traveling jaws of the reciprocating feed which automatically carry them to each of the three dies *B*, *C*, and *D* in consecutive order, finally discharging the finished product at the other end of the press.

The revolving dial *A* is driven by a round belt from a grooved

pulley on the flywheel shaft. This belt is changed from a vertical to a horizontal position to drive the pulley attached to the dial shaft by means of idlers. The reciprocating motion of the traveling jaws *E* is derived from lever *F*, which is actuated by the "race cam" *G* on the end of the crankshaft. The automatic opening and closing of the jaws *E* is accomplished by motion transmitted from cam *H* through bellcrank *I*, link *J*, rod *K*, link *L*, and levers *M* and *N*. By means of the handle *O*,

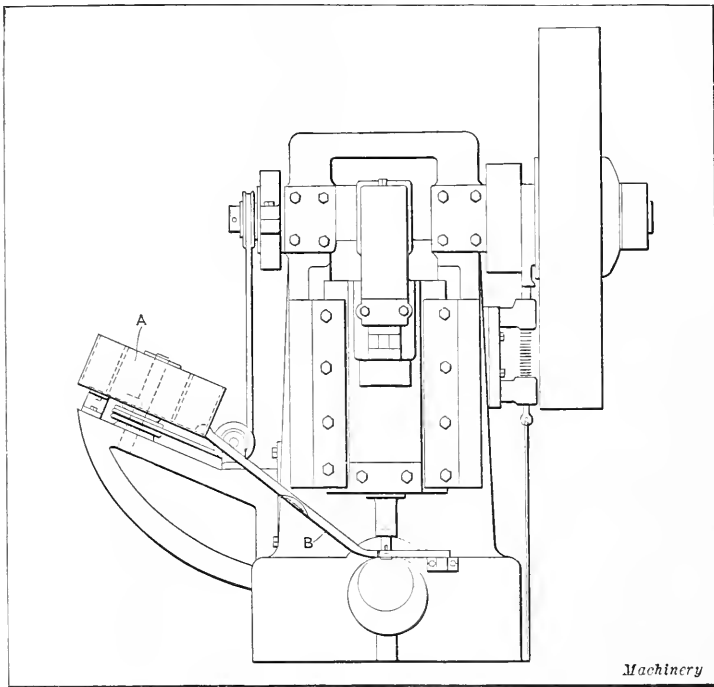

Fig. 13. Chute and Hopper Feed Arrangement

the traveling jaws *E* may be independently opened at any position. After the first three revolutions of the crankshaft, the press performs three operations at every stroke.

**Chute and Hopper Feed.** — The development of the automatic manufacture of tin cans and articles of pieced tinware has brought out many automatic feeds and other press attachments. An interesting automatic feed for this class of work is shown



in Fig. 13. A horning and riveting press is here shown fitted up for automatically assembling and clinching the ears on lard pails, for holding the wire which forms the pail-handle. Instead of the operator using one hand to hold the pail and the other to place the ear on the clinching die, he merely places the pail on the die, which is attached to the horn or mandrel shown, trips the press, and the punch, descending on the pail and ear (the latter being previously fed to and located on the lower die), securely clinches the two tightly together. The revolving hopper *A* is filled with ears, and as it rotates the ears fall by gravity through the various openings in the side or wall of the hopper

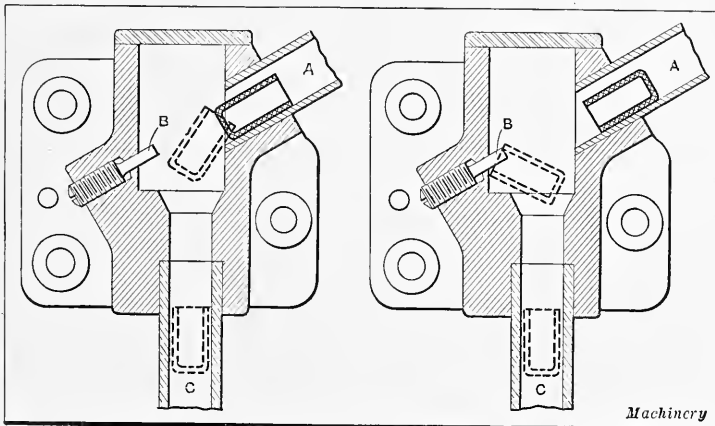

Fig. 14. Simple Feed Chute Attachment for Turning Shells which Enter Open-end Foremost

and into the chute *B*. The chute does not convey the ears directly to the die, but to a point about  $1\frac{1}{4}$  inch to the rear of the die. The press and dies are fitted with a sliding arm or feed finger located at the rear of the dies and connected with the slide or ram of the press proper by means of a pair of links. As the slide recedes from the work on the up-stroke, these links force the sliding feed-arm forward a fixed distance, and as the arm moves past the open end of the chute, it carries one ear forward and onto the dies. The arm remains in this position until the press is tripped. When the press is tripped and the slide descends, the motion of the links returns the feed-arm to

its normal position at the rear of the dies, permitting another ear to slide down in front of it. This arrangement gives the operator the entire use of both hands.

**Feed Chute for Drawing Press.** — An interesting form of feed chute that is used to prevent the breakage of drawing punches is shown in Fig. 14. The press on which this device is used is employed in performing a drawing operation on the cups shown in the illustration. These cups enter the chute *A* from a hopper and pass down quite rapidly; when the bottom of the cup strikes the pin *B* the cup rebounds and drops into the feed-pipe *C*, which leads to the feed fingers of the press. It is necessary to have the cups feed into the press with the closed end down, but sometimes a cup enters the chute *A* in an inverted position, as shown by the right-hand view. If the cup reached the die in this position, it would result in breaking the drawing punch. A simple and ingenious method of turning a cup is indicated by the illustration to the right. If the cup enters the chute *A* with the open end foremost, it slides down until it catches on the pin *B*, and, instead of rebounding, swings on the pin *B* and drops into the feed-pipe *C* with the closed end down in the manner illustrated. This feed chute is carried by a bracket which is attached to a stationary part of the press.

**Knockout for a Punch-Press.** — The mechanically operated knockout shown applied to a punch-press in Fig. 15 operates more satisfactorily than a rubber bumper — especially for brass forging dies and small redrawing dies — and is less expensive.

The view to the left shows the attachment in place on a punch-press. Referring to this illustration, *A* is a crank disk which is bored out to fit over the projecting end of the crankshaft to which it is fastened by means of two bolts shown at *L*. (See detail view at the right.) Adjustment of the length of the stroke is provided by means of a T-slot in which the crank-pin *K* is secured, and the knockout can be timed to suit the requirements of the work on which the press is engaged by loosening bolts *L* and turning disk *A* to the right or left with relation to the crankshaft. The hubs *B* at each end of the connecting-rod *C* are alike, except that one hub is threaded right-hand and the

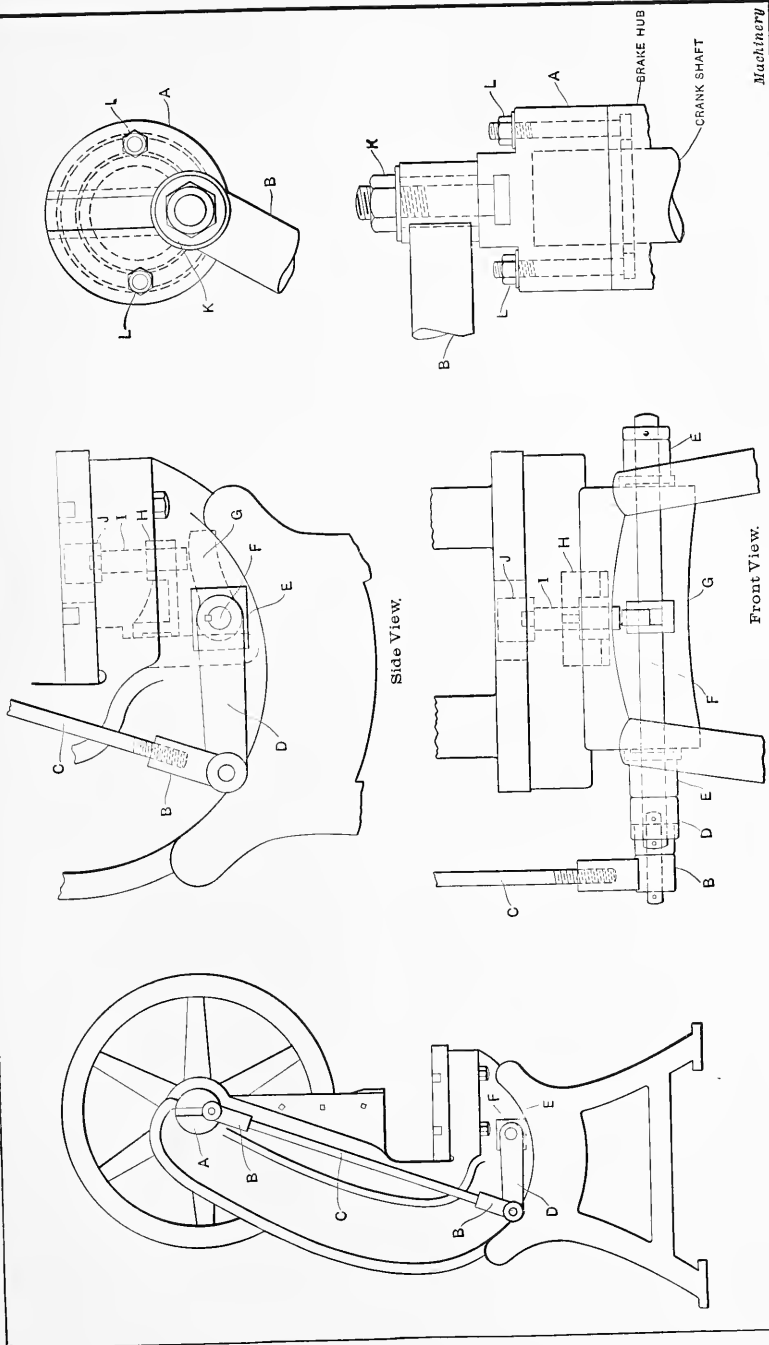

Fig. 15. Power Press Equipped with Mechanical Knockout, and Views showing Details of Design

other left. The connecting-rod *C* has a flat on it which can be engaged by a wrench, and by turning the rod a very fine adjustment of the knockout is secured. Further adjustment may be made by using different sizes of washers *J* and knockout pins *I*.

The collars *E* support bearings in which the shaft *F* turns and these collars have four short legs cast on them, it being possible to file the legs to compensate for irregularities in the frame of the punch-press on which the attachment is to be applied. The collars are fastened to the bed of the press by four half-inch cap-screws. The crank *D* is keyed to the shaft *F* and the same method is used in securing the cam *G* in place. The bracket *H* has four short legs cast on it so that it may be fitted to the rough bed casting and fastened by two cap-screws. The hole in this bracket is bored large enough so that the knockout pin *I* is a sliding fit in it.

The method of adjusting this attachment is as follows: When the ram of the press is in the upper position, the crank *A* is set with the slot vertical. The hub *B* is next fastened to the lower end of the slot by means of the stud shown at *K*. On the downward stroke of the ram, the crank disk *A* makes one-half revolution, thus raising the connecting-rod *C* and crank *D*. The cam *G* turns and lowers the knockout pin *I* and collar *J*. Then when the ram begins its up-stroke, the crankshaft completes the revolution, pushing down the connecting-rod *C* and the crank *D*, and raising the pin *I* and collar *J* through the action of the cam *G*. In this way, the work is ejected from the die. In some cases corrugations are milled on the inside of the crank disk and the brake hub, to prevent the collar from slipping.

**Ejecting Press Work with Air Blast.** — An arrangement for blowing work from a forming die in a punch-press, by means of compressed air, is shown in Fig. 16. It is simple and durable, and is used on about forty presses in a large plant, with satisfactory results. The illustration shows a plain forming die in position under the plunger of a press, while at the left of the plunger is the air valve *A* with its attachments. This valve is a Lunkenheimer whistle valve. It is held by the pipes which are screwed into each end, these pipes being held by the brackets

which are screwed to the frame of the press. Below the valve there is a union and some other connections, and a bent tube which may be turned so as to apply the jet of air most advantageously. In some cases two unions are used to facilitate the adjustments. The lever of the whistle valve has been removed and in its place the trigger is mounted. This trigger is so

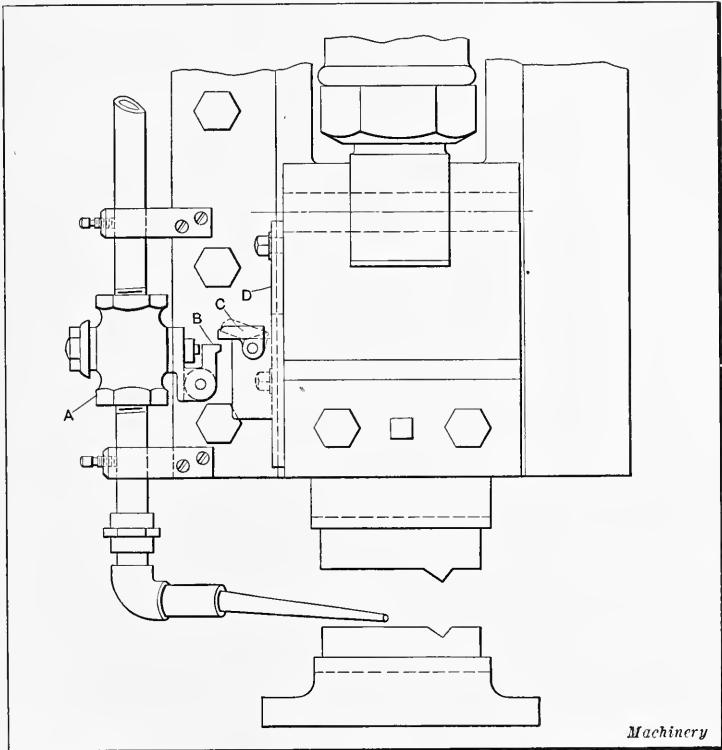

Fig. 16. Pneumatic Press Attachment for Automatically Removing Work

designed that it remains vertical when not in action; it is seen in position against the plunger of the valve. The trigger is operated by the pawl *C* which is mounted on the bracket *D*. The bracket is made of angle iron and is provided with two long slots for adjustment when the dies vary in thickness.

As the plunger descends, the end of the pawl *C* rises, as shown by the dotted outline, and passes below the head of the trigger

B. On the upward stroke the end of the pawl engages the cam on the end of the trigger and thus operates the valve. In this way a jet under full pressure is suddenly directed against the work, blowing it out of the operator's way before the plunger reaches its highest position.

Another arrangement for blowing away finished stock from a punch-press is illustrated in Fig. 17. As there was no compressed air of sufficient pressure available, an independent pump

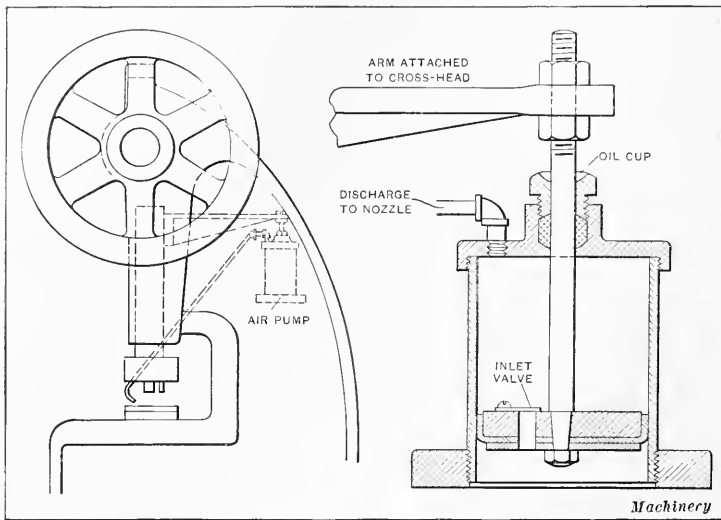

Fig. 17. Press Equipped with Air Pump for Ejecting Work — Enlarged Section of Pump

was attached to the press, as shown. The piston-rod of this pump is connected to the cross-head of the press, and, consequently, the pump has the same stroke as the throw of the crankshaft. The air is compressed on the up-stroke, and it is delivered against the work by means of a  $\frac{1}{8}$ -inch pipe which is fitted on the end with a nozzle. The pump cylinder is made of a piece of 3-inch brass tubing which is screwed into a baseplate, as shown in the enlarged sectional view. This tubing is fitted with a head containing a stuffing box, and a  $\frac{1}{8}$ -inch pipe outlet. The piston is a regular 3-inch hydraulic cup, and a piece of leather belting is used as packing. A piece of leather fastened by one screw to the inside of the piston, acts as an inlet valve.

## CHAPTER VIII

### TOOLS FOR PERFORATING CYLINDRICAL AND CONICAL WORK

The punches and dies used for perforating the sides of cylindrical work are similar to blanking punches and dies, except for the modifications necessary, owing to the fact that the metal which passes over the face of the perforating die is circular in form instead of being flat. Circular perforating tools are used in connection with this class of work because the nature of the work is such that, on account of both commercial and mechanical considerations, it cannot be carried out in any other way.

In Fig. 1 is shown a set of perforating tools together with a perforating attachment set up in a press ready for perforating a shell similar to the one shown in Fig. 3. The shell is first slipped over the die-holder (Fig. 4) in such a manner as to allow the elongated slot *A* in the bottom of the shell to engage with the projecting tongue of the driving arbor. The press is then tripped and the punches, at the first stroke of the press, cut out two of the irregular shaped perforations *B* in the shell. On the upward stroke of the press, a pawl *A*, Fig. 1, by the aid of a ratchet *B*, ratchet shaft *C*, and the bevel gears, revolves the driving arbor, which rotates the shell a part of a turn. As the slot in the bottom of the shell is engaged with the tongue of the driving arbor, the shell is indexed with the arbor before the punch descends again. These operations are continued until the press, in this case, has made fourteen continuous strokes, when it is automatically stopped and the perforated shell removed. The stopping of the press is effected by cam *D*, which automatically releases the driving clutch when the required number of strokes has been made. The construction of the tools and the manner in which they are made will be treated later.

In Fig. 5 is shown another set of perforating tools for per-

forating the gallery fence of a lamp burner shown in Fig. 6. The gallery fence of a lamp or gas burner holds the lamp chimney or globe in place by the spring pressure exerted by the perforated part. The metal must be hard in order to impart the required spring pressure and is, therefore, on the better grade of burners, burnished before perforating, which not only hardens and toughens the metal, but also produces a brilliant finish. On

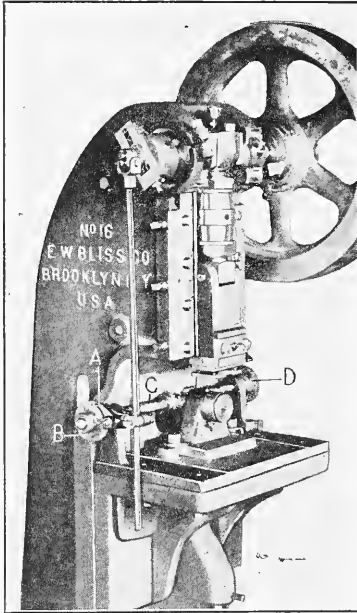

Fig. 1. Press with Attachment for Perforating Shell shown in Fig. 3

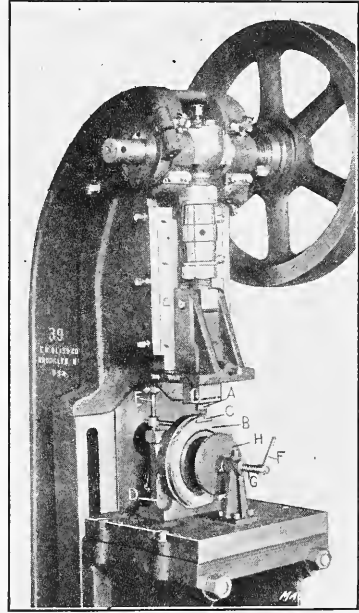

Fig. 2. Perforating Attachment with Special Device for Holding Shell in Place

the cheaper grade of burners, the shells from which the gallery fences are made are passed through an extra redrawing operation, the shells not being annealed, but left hard. The difference in the diameter of the shell before and after redrawing is about  $\frac{1}{32}$  inch, while the difference in the thickness of the metal is about 0.0005 inch. This treatment of the metal not only imparts the required springiness, but also makes the perforating operations easier, because hard metal is more readily perforated than soft.



The tools used for perforating the gallery fence shown in Fig. 6 are somewhat different in construction from those shown in Fig. 1. The ratchet *C*, Fig. 5, is keyed to the driving arbor, and when the tools are set up in the press they are set with the face of the die-holder turned towards the right, instead of facing the operator. The perforating operation, however, is similar to the one already described. The effect of the successive strokes of the press is indicated in Fig. 6. At the first stroke of the press, the four shaded areas at *F* are punched out. At *G* can be seen the appearance of the shell after the second stroke.

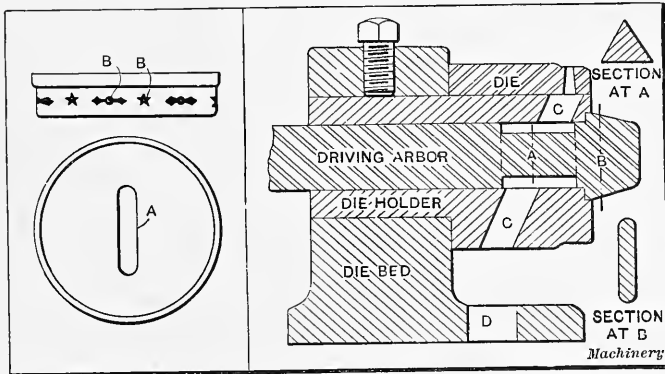

Fig. 3. Example of Shell to be Perforated      Fig. 4. Section of Die-bed, Holder and Die for Perforating Shell shown in Fig. 3

In order that no burr or fin may be left on the top points of the scallops, the die is made so that the punch will cut a trifle past the center of the point as shown at *H*. The shell is rotated towards the left by the driving arbor, and a simple holding device, not shown in the illustration, is used for holding the shell in place on the arbor.

An attachment for holding work in place while it is being perforated is shown in Fig. 2. This attachment is used in connection with the tools for perforating the sides of large narrow rings. The tool equipment consists of a perforating punch *A*, and a large die-holder *B* for holding the dovetailed perforating die *C*. The die-holder is held in die-bed *D*. The perforating attachment, which rotates the shell, is placed directly back of the die-bed and is operated by the adjustable connection *E*,

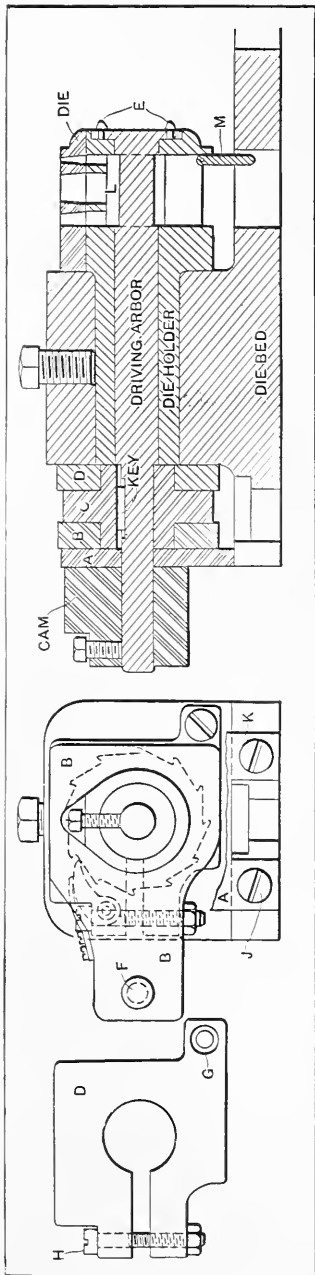

Fig. 5. Section of Die-bed, Holder and Arbor for Perforating Shell shown in Fig. 6

fastened to the gate of the press. After the ring is slipped over the die-holder, handle *F* is given part of a turn to the right which, by means of the spiral grooved arbor *G*, causes the circular disk *H* to come in contact with the ring, thus holding it in place. This circular disk rotates with the ring and is attached to arbor *G* by a pin in the hub of the disk which engages with a circular groove in the arbor.

**Construction of Perforating Tools.** — In Fig. 7 the perforating die for the shell in Fig. 3 is shown held in a dovetail channel in the die-holder. The die-holder is preferably made of a cheap grade of tool steel, and is held in the die-bed as shown in Fig. 4. The dovetail method for holding the dies is probably the best, and is the one most commonly used. The sides of the dies are beveled at an angle of from 5 to 10 degrees. For work such as shown in Fig. 3, the die is tapered lengthwise on one side with a taper of about 1 degree, and is driven into the die-holder from the back and left flush with the shoulder of the holder, so that, when in position, the die-bed prevents it from shifting back. When it is possible to do so, a pin or a fillister-head screw may be used to prevent the

die from shifting endwise. The shape of the shell and the design to be perforated sometimes govern the taper of the sides of the die. This, for example, is the case where shells such as shown in Figs. 9 and 11 are perforated, when a greater angle than 1 degree must be used on account of the irregular shape of the die-holder and dies.

The longitudinal cross-section of the die-bed, die-holder, and driving arbor used for the shell in Fig. 3 is shown in Fig. 4. Section *A* shows how the arbor is milled at the neck *A* in order to allow the scrap punchings to drop through. A section of the

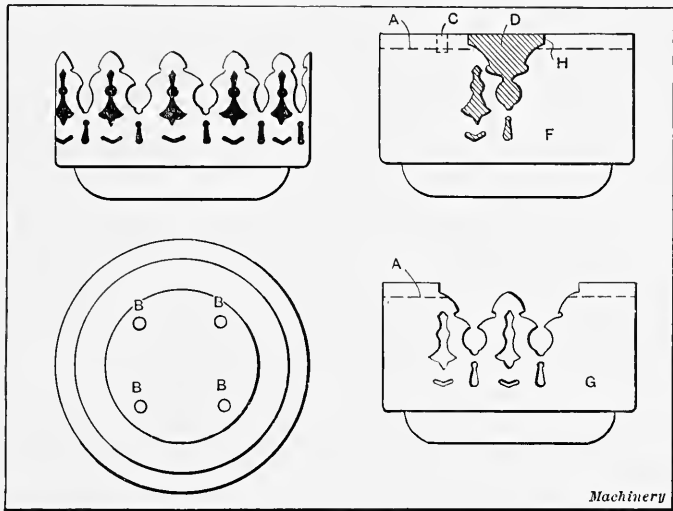

Fig. 6. Example of Shell Perforating

tongue of the arbor which engages the slot in the end of the shell, by means of which it is rotated, is shown at *B*. This tongue is tapered as shown, to facilitate the putting on and taking off of the work. A scrap escape hole *C* is drilled in the die-holder at an angle as shown, so as to prevent the scrap punchings from coming in contact with the shell while it is rotated around the die. An escape hole drilled in this manner can be used only on short shells and when the scrap punchings are small, or, if they are large, when they are few in number. Hole *D* in the die-bed permits the scrap punchings to readily fall out of the way.

The construction of the tools shown in Fig. 5 is somewhat different. Two small pins *E*, which are used in the face of the driving arbor, act as driving pins for rotating the shell. These enter into pierced holes in the bottom of the shell as shown at *B*, Fig. 6. The pawl which operates the indexing ratchet is

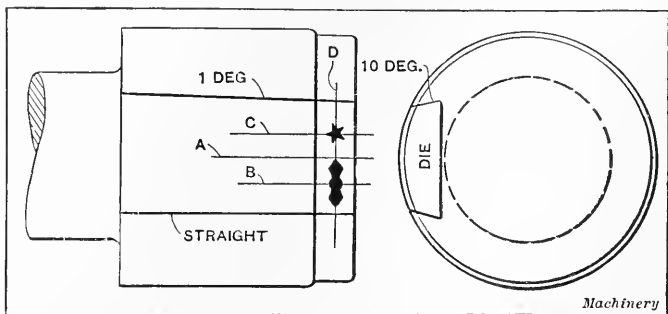

Fig. 7. Die in Position in Die-holder

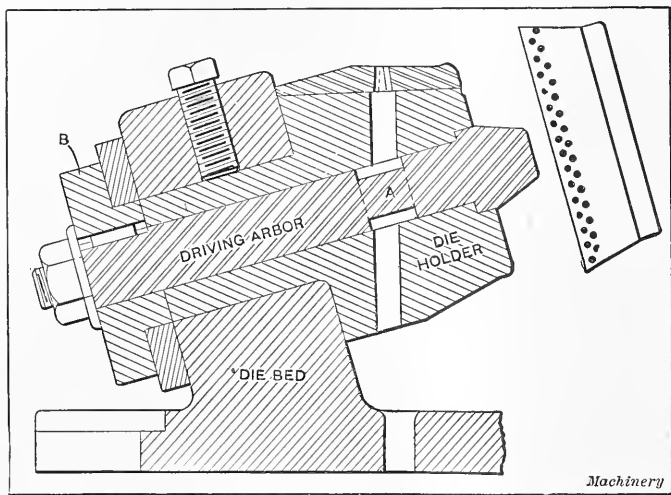

Fig. 8. Die, Die-bed and Holder for a Tapered Shell

fastened to part *B* in Fig. 5, which is made to fit the shoulder of the ratchet and works back and forth in order to provide for the required indexing. The back-and-forth motion is imparted to *B* by fastening a handle *F* to an adjustable connecting-rod which, in turn, is fastened to the crankshaft of the press. Part *D* is a brass friction which takes up the backlash of the driving

arbor. This friction is fastened to the die-bed by a screw at *G*. The hole in the center of the friction fits the shoulder on one end of the ratchet. The brake or friction effect is applied by screw *H*. Part *A* acts as a steadyrest for the driving arbor, and is fastened to the die-bed by screws *J* and *K*.

The cam fastened to the end of the driving arbor causes the press to stop automatically by coming in contact with a lever connected to the driving clutch. The driving arbor is relieved at *L* to prevent the congestion of the scrap punchings. The hole for the driving arbor in the die-holder is also recessed at this

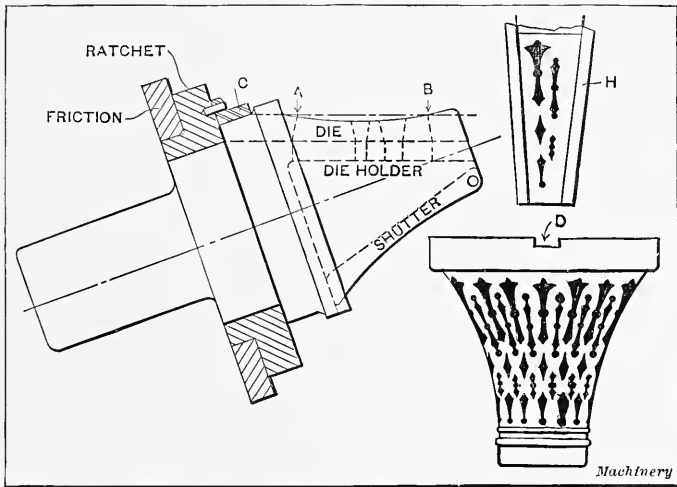

Fig. 9. Die and Holder for Perforating Shell shown to the Right

place in order to give the scrap punchings, which, in this case, are rather large, ample room to pass the arbor. When the device is in operation, a shutter *M* closes up the bottom of the scrap escape hole in the die-holder. When the shell is slipped over the latter, the shutter is forced up and thus acts as a trap, preventing the punchings from dropping through into the inside of the shell. If the punchings were allowed to drop through and should cling to the perforated holes, they would cause the shell to jam and prevent it from rotating. When the perforated shell is removed from the die-holder, the shutter drops down of its own accord, thereby allowing the scrap punchings to drop out.

**Perforating Shells of Tapered and Irregular Shapes.**— In perforating shells of tapered and irregular shapes the same general methods of procedure as already described are used, with the exception that the die-holder is held in the die-bed at an angle of 5 to 70 degrees or more with the bottom of the die-bed, the angle depending on the shape of the shell and the perforations to be made in it. In Fig. 8 is shown a die, die-holder, and die-bed for work of this kind. The angle at which the die-holder is set should be such that if the outer ends of the two extreme holes in the perforating die are connected by a straight line, this line would be parallel with the bottom of the die-bed, as indicated in Fig. 9, where the points *A* and *B* are on the line which should be parallel with the base of the die-bed.

In Fig. 8 may also be seen the shell which is perforated by the die. The shell is rotated around the die by the tongue of the driving arbor engaging in an elongated hole in the bottom of the shell. The arbor is relieved at *A* in the usual manner to allow the scrap punchings to escape. No shutter is used, as the open end of the shell does not come near the scrap escape hole. The ratchet *B*, which is operated by a pawl, not shown, is keyed to the driving arbor, while the friction used for controlling the backlash bears upon the shoulder of the ratchet as indicated. This shell has two rows of perforated holes, fifty-two holes in each row. Eight holes at a time are cut, or four holes in each row. The reason that four holes in each row are cut at each stroke, instead of five, six, or eight, is, in the first place, that the number of holes cut at each stroke of the press must be such that the total number of holes in each row is a multiple of it. In the second place, it is not possible to get good results if the end punches are too far away from the center of the work, as these punches would strike a glancing blow. These holes would be somewhat elongated and “burry” instead of being clean, round, and free from burrs. In this case, four holes in each row is as much as is practicable. Of course, if the holes are small in diameter and close together, a greater number can be cut at one time than when they are larger and further apart. If the diameter of the shells is large, a greater number of holes can also

be cut at one time than with shells of smaller diameter, other conditions being equal.

In Fig. 10 is shown another set of perforating tools set up in a Bliss press. These are used for perforating the sides of the tube shown at *A* with a series of rows of small holes. These tools are of a somewhat different type from those already described. No driving arbor is used, but the shells are rotated direct from the ratchet which is placed in front of the die-bed. There may be several reasons for using this construction: When

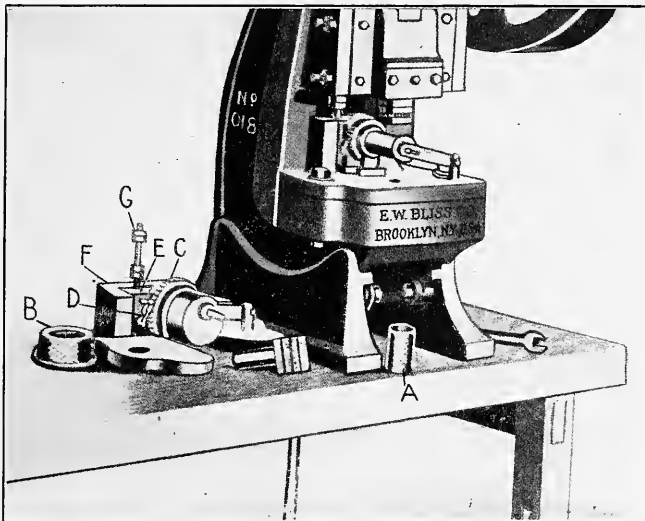

Fig. 10. Tools for Perforating Special Cylindrical Shells

the bottom of the shell is to be left intact, no driving arbor can be used; sometimes the required shape of the shell is such as to prevent the use of a driving arbor; when the scrap punchings are so large and so numerous as to prevent them from dropping through if a driving arbor is used, or when that part of the shell that is to be perforated is very small in diameter, it may also be impossible to use a driving arbor.

Referring again to Fig. 10, it will be seen that another set of perforating tools similar to the one set up in the press is shown to the left. This is used for perforating the shell shown at *B*. The ratchet and pawl are shown at *C* and *D*. The latter is

fastened to the dovetail slide *E* in the die-bed *F*. This slide is operated by the gate of the press by connection *G*. The holding-on attachment consists of a slotted stud in the die-bed to which a swinging arm is pinned. A circular disk which revolves with the work is fastened to this arm, as is also the small handle directly in front of the attachment. This handle is used by the operator to swing the arm up and out of the way preparatory to removing the perforated shell from the die-holder.

**Methods of Rotating Shell to be Perforated.** — A method commonly used in connection with perforating tools for rotating the shell to be perforated is the dog-notch method. A dog *C*, Fig. 9, is fastened to the ratchet by screws or dowel-pins. The end of this dog fits a notch *D* in the shell, called the "dog-notch." The shell is slipped over the die-holder in such a manner as to cause the dog-notch in the shell to engage with the dog on the ratchet. In this way the ratchet can index the shell directly around the die-holder.

There are also a number of other methods used for rotating shells to be perforated. Besides those already described, one may make use of an irregular shaped hole in the bottom of the shell in connection with the driving arbor. Sometimes an irregular shaped hole is required in the bottom of the shell, and in such a case the tongue of the driving arbor may be made to fit this hole, which affords a good driving means. Sometimes use is made of a coaster brake device fastened to the ratchet. The tools used in connection with this device are similar to those already described, having the ratchet in the front of the die-bed, as shown in Fig. 9, with the exception that instead of using a dog, a device working on the principle of a coaster brake, such as is used on an ordinary bicycle, is fastened to the ratchet. With this device, no notch in the shell is required, as the open end of the shell is simply slipped into this device and given a part of a turn, causing it to be tightly gripped. The press is then tripped and the shell rotated around the die in the usual manner. In cases where a dog-notch is used and where there is a tendency on the part of the shell to slip in between the dog and the die-holder, which would prevent the shell from being



properly rotated, the die-holder is turned down as shown in Fig. 9, and the dog is made to just clear the holder. This prevents the shell from slipping in under the dog.

The perforating die shown at *H* is held in the die-holder in the usual way, and is tapered lengthwise at a suitable angle as indicated. In order to afford a support for the die when in use, the bottom of the dovetail channel upon which the die rests is worked out so as to conform to some extent to the shape of the bottom of the die. This is done on dies where the holes are close together, so as to support the narrow bridges that separate

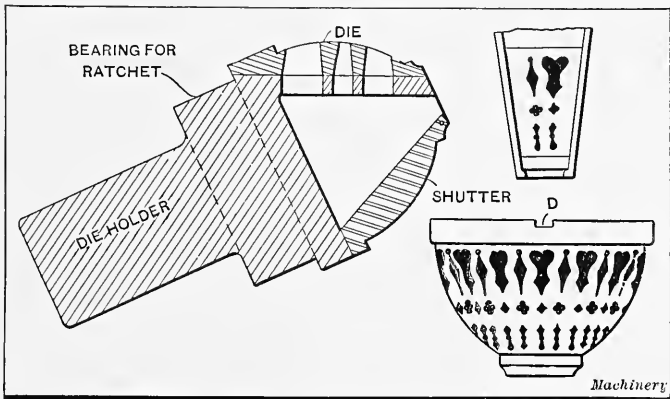

Fig. 11. Die and Holder for Perforating Shell shown to the Right

the irregular shaped holes in the die. The best way to do this work is to first work out an open space under the dovetail channel. This space is used for holding the scrap punchings that are prevented from dropping through by a shutter. In working out this space enough stock is left under the dovetail channel to support the die properly, as indicated in Figs. 9 and 11, after which the openings through which the scrap punchings from the die drop are worked out. The shutter, which is shown closed in Figs. 9 and 11, swings open on the shutter pin as soon as the perforated shell is removed from the die-holder.

The construction of the tools in Fig. 11 is similar to that of those just described. At the right is a plan of the die, showing the manner in which the die is tapered lengthwise, which in this case is six degrees on each side. When the tools shown in

Figs. 9 and 11 are in operation, two rows of holes are cut at every stroke of the press until the shell has completely rotated around the die and all the required rows of holes have been punched out. No device is used with these tools for holding the shells in place while they are rotating around the die, because the position of the die-holder in the die-bed makes it easy for the operator to keep the shell in place.

It sometimes happens that a perforated shell of the general type shown in Fig. 6 is required, with the exception that the bottom is left intact and therefore cannot be used in connection with a driving arbor for rotating the shell. In such a case, the shell is dog-notched and rotated in the manner already described, with the exception that the locating of the dog on the ratchet preparatory to perforating the shell forms an important part in the successful operation of the tools. The reason for this is that when cutting out the scallops of the shell the dog-notch *C*, Fig. 6, which is used for rotating the shell, must necessarily be cut away from the shell, and must, therefore, be placed in such a position that it will come in the center of the large scrap punching which will be cut out at the last stroke of the press, completing the operation. If the shaded portion shown at *D* is the punching resulting from the first stroke of the press, and if the blank is rotating from right to left, then the dog-notch must be located at *C*, central between the two scallops completed by the last stroke of the press, after the whole shell has been perforated.

In order to prevent the punch *A*, shown in the upper right-hand corner of Fig. 12, which cuts out the scrap punchings *D*, Fig. 6, from coming in contact with the dog, a short slot is milled in the center of the face of the punch at the back end near the ratchet, so that the punch will clear the dog when that part of the shell containing the dog-notch is cut out.

**Lay-out of a Perforating Die.** — Preparatory to laying out the die shown in Fig. 7, the die blank is carefully fitted to the dovetail channel in the die-holder, after which it is turned up in the lathe in place and highly polished. It is then removed from the die-holder and blued by heating, and again driven into the

die-holder, after which it is ready to be laid out. The die-holder is then mounted in the milling machine, the index-head in this case being set for twenty-eight divisions, as there are fourteen perforated holes of one design and fourteen of another. With a surface gage and by aid of the index head, the center-lines *B* and *C* are scribed. Line *A* is drawn merely to show the

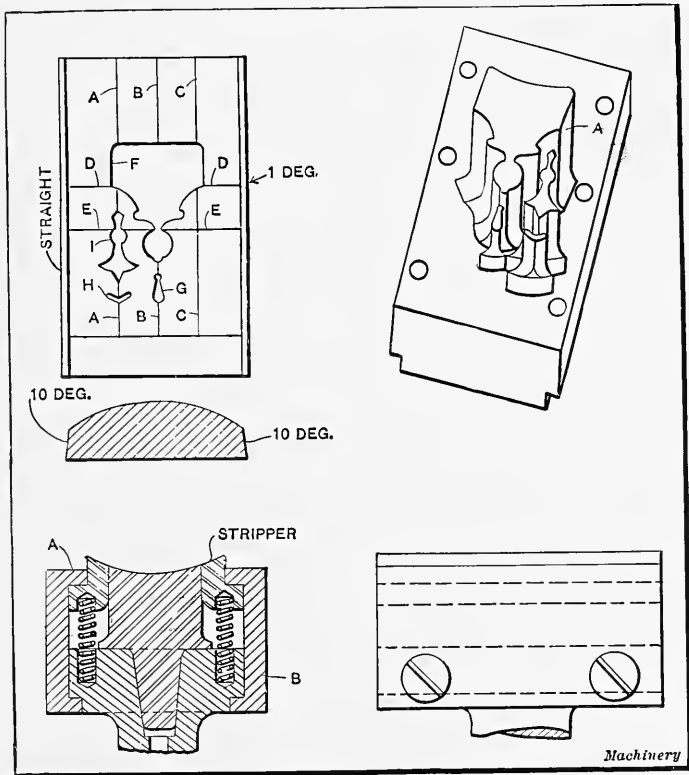

Fig. 12. Perforating Punch and Die

center of the die, and the center of each one of the holes in the die should be an equal distance from this line. Center-line *D* is next scribed the required distance from and parallel with the face of the die-holder.

In laying out the hole on the center-line *B* a small circle of the exact diameter of the circular opening in the center is first scribed. The diamond-shaped ends are next laid out and scribed.

The star-shaped hole on the center-line *C* is laid out from a master punch which conforms to the required size and shape. In cases where the required number of shells to be perforated does not warrant the making of a master punch, the dies are laid out from the star-shaped punch that is used in connection with the die.

In working out the die, the central hole from which the star design is made is first drilled and taper-reamed from the back to the size of the teat on the master punch, which is equal to the diameter of the circle passing through the bottom of the grooves in the star. The teat of the master punch is then entered into the die and the punch set and clamped to the die so that a point of the star is on line *C*. The outline of the punch is then scribed on the face of the die, after which the die is worked out and fitted to the punch. In order to facilitate matters, the punch is used as a broach after the die is filed to shape. In working out the other hole in the die, on line *B*, a hole is first drilled and taper-reamed from the back for the circular opening in the center. Two holes are drilled and reamed in the center of the diamond-shaped ends. The surplus stock between the drilled holes is then removed and the hole filed to the desired shape.

There are two ways in which a die such as that shown in the upper left-hand corner of Fig. 12 may be laid out. One is to lay out the die on a milling machine in a manner similar to that already described. The other, which is most commonly used, is to lay out the die by scribing the design on its face from a master shell slipped over the die-holder which has the shape to be perforated worked out upon it.

The master shell itself is laid out as follows: The shell is fastened to the die-holder by a few drops of soft solder to prevent it from moving. The die-holder is then mounted in the milling machine. The index-head in this case is set for twenty-four divisions. In Fig. 12 is shown the laying-out of the die, but the same method applies to the shell. With a surface gage used in connection with the index-head, the lines *A*, *B*, and *C* are scribed on the shell. Lines *A* and *C* represent the centers of two adjoining scallops, and line *A* is also the center for the two

holes *I* and *H*, while line *B* is exactly in the center between two scallops and constitutes the center-line for hole *G*. The lines *E* and *D* are next scribed on the shell, the former representing the height of the ears of the projecting scallops, while the latter shows the height at which the lower curved portions of the pointed scallops converge. After these construction lines are scribed on the shell, the design is readily laid out. The shape of the design is then worked out by drilling and the surplus stock is removed by means of a jewelry saw. The shell is then filed to the desired shape and when completed should be a duplicate of the portion cut out by the first stroke of the press, as shown at *F* in Fig. 6. In filing out a design, care should be taken to file out all the holes central with the center-lines *A*, *B*, and *C*, and also parallel with a plane passed at right angles to the center of the design, through the shell, in order that the holes may be at their exact required position on the inside of the shell.

It will be noted in Fig. 12 that the large hole *F* in the die is extended past the line *D*; this is done in order to make sure that the large scrap punching *D*, Fig. 6, will be completely cut from the shell. This is especially necessary when the shells vary in length. The dotted line *A*, Fig. 6, is drawn so as to more clearly show the length of the twelve pointed scallops and their relation to the top of the shell.

In drilling and working out the surplus stock in the die, Fig. 12, the same general methods that are used for working out an irregularly shaped blanking die are used. First, remove as much of the surplus stock as possible by drilling. When drilling out the surplus stock in the hole *F*, the smaller of the two circular openings between the scallops is first drilled out and taper-reamed from the back to the finish size. After this, the hole is plugged with a small taper pin that is filed to fit it, and the large hole is drilled and taper-bored in a lathe. The round corners at the opposite end of the hole are then drilled out. These corners are left circular in order to add to the strength of the die and to prevent cracking of the die in hardening. The remainder of the hole is drilled and worked out in the usual

way. In working out the small holes *G* and *H*, the opposite ends are first drilled and taper-reamed to the finish size, after which other holes are drilled and reamed and the surplus stock is removed with a small broach or jewelry saw preparatory to filing out the die. Hole *I* is drilled out and the surplus stock removed in a similar manner.

**Filing Out the Die Shape.** — A die used for perforating the sides of cylindrical work is rather awkward to hold, either in

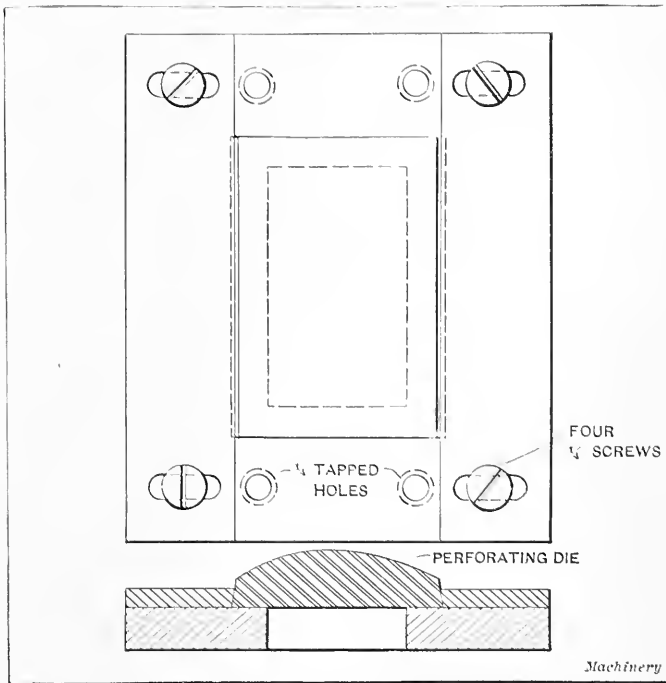

Fig. 13. Device for Holding Perforating Dies while Filing

the vise or in die-clamps, while being filed out, owing to the fact that the face of the die is circular in shape and the sides are dovetailed. For this reason, a die-holding fixture, shown in Fig. 13, is used to hold the die in the vise, die-clamp, or filing machine while it is being filed out. The device shown is adjustable to accommodate various widths of dies. The most essential points to be remembered when filing out a perforating

die are: Use a coarse file for the rough filing and finish with a smooth one. Take care to have the clearance filed straight in order to prevent the congestion of scrap punchings in the die; perforating dies as a rule are not very strong and are often cracked and broken because of neglect on this point. The clearance should not be filed over  $1\frac{1}{2}$  degree, in order to make the die as strong as possible; in cases where the holes in the dies are close together even less clearance is necessary, and a very narrow wall that separates two holes is filed almost straight on each side, with just enough of a taper to clear. Care must be taken when filing to prevent the back or the sides of the file from running into the finished part of the die.

**Making the Punch for a Perforating Die.** — The punch used with the die shown in Fig. 7 is comparatively simple in its construction. It consists of the usual form of punch-holder into which the two perforating punches are driven. The star-shaped punch, after it is fitted to the die and hardened, is driven into the punch-holder in such a position that when it is entered into the die the sides of the punch-holder will be in a straight-line and parallel with the die-bed. The tools are then set up in a hand or foot press so that the die and star punch are in proper alignment with each other. The foot treadle of the press is then disconnected from the gate so that the gate which holds the punch-holder in place can be withdrawn from the press without disturbing the punch-holder or the ways upon which the gate slides. The other punch, in its unfinished state, is then driven into the punch-holder and the face is coated with a  $\frac{1}{16}$ -inch thickness of soft solder. The gate of the press is then slipped back into place and the impression of the outline of the die is transferred to the solder on the face of the punch. The punch-holder is then removed from the press and the punch driven out and milled to conform to the soft solder outline of the die, after which the punch-holder is put back into the press, care being taken to see that the star-shaped punch is in proper alignment with the die. The milled punch is then put back in place and gradually sheared and fitted to the die. Each time after the punch has been lightly sheared into the die, the fins and

surplus stock are removed and the punch is again entered and sheared a trifle deeper, until it enters the die at least  $\frac{1}{4}$  inch.

The hand or foot press is very convenient to use when fitting perforating punches to their dies, because the construction of the press makes it possible to handle the gate conveniently and to keep the punches in proper alignment with the die.

In making perforating punches such as shown in the upper right-hand corner of Fig. 12, the punch-holder is first machined to the desired shape and size, after which the taper hole for the shank of punch *A* is reamed. The shank of the punch is then turned and fitted to the punch-holder and driven into place. The face of the punch is made to conform to the outside diameter of the shell and is then clamped to the face of the die and the outline scribed on it, after which it is milled to shape and sheared and fitted to the die. Before scribing the outline of the die on the face of the punch, care must be taken to see that the punch is set in the proper relation with the die, so that, when the finished tools are set up in the press, there will be no necessity for elongating or widening the slots in the die-bed used for clamping the die to the bed of the press, due to the punch not being laid out central with the die.

After the first punch *A* has been fitted to the die, the holes for the other three punches are laid out so that the cutting part of the punches will be as nearly central with the shanks as possible. Holes are then drilled and reamed for the shanks, and when this is done punch *A* is hardened. The reason that this punch is hardened before the other punches are fitted to the die is that if the punches were all sheared and fitted together and then punch *A* should spring in hardening, it would cause great difficulties in again bringing the punches into proper alignment with the die. After punch *A* has been hardened and driven back into the punch-holder, the shanks of the other three punches are turned up and fitted to the respective holes into which they are afterwards driven. The shanks of these punches may be made either straight or tapered, but should be a good driving fit and should have shoulders bearing against the punch-holder.

Before the punches are driven into place, the die and punch



*A* are set up in the foot press and properly aligned with each other. The gate of the press is then withdrawn, the three punches are driven into place, and the faces coated with soft solder. The gate of the press is then slipped back into place and the outline of the die transferred to the punches, after which they are driven out and milled separately in the milling machine. Sometimes the punches cannot be driven out from the back of the punch-holder, because if the holes for these punches were drilled through they would run into and weaken the shank of the holder. In such cases holes are drilled from the side to meet the shank holes, in order to allow a taper drift to be used for starting the punch so that it can be removed.

After the punches have been milled, they are driven back into the punch-holder and are sheared and fitted into the die, as previously described. The punches, of course, are lined up perfectly with the die so as to enter into their respective holes as one single punch. After the punches are hardened they are sharpened by holding the punch-holder in a special grinding fixture and drawing the punches back and forth across the face of a wheel of about the same diameter as the shell to be perforated. The bases of the punches are strengthened by milling the punches so that there is a liberal fillet between the shoulder of each punch and the milled-out shape. This also tends to prevent distortion in hardening.

**The Stripper of a Perforating Die.** — The stripper serves three purposes: It strips the metal from the punch; it supports the small punches by preventing them from springing; and it tends to keep the perforated shell in shape by preventing it from bending or becoming “kinked up.” The commonly used stripper construction is shown by the lower view, Fig. 12. The face of the stripper conforms to the outside diameter of the shell. It is drilled and worked out so that it is a sliding fit on the punches. The shoulder part of the stripper bears against the bottom lugs of the side pieces *A* and *B*, which are fastened to the punch-holder and prevent the stripper from being forced off the punch. Six spiral springs exert the required pressure on the stripper. When setting up the tools in the press, the stripper is

forced back about  $\frac{1}{8}$  inch and two pieces of, say, No. 31 drill rod are placed between the stripper and the bottom lugs of the side pieces, which keep the stripper out of the way while the punch and die are aligned with each other.

Perforating dies of the type described are sharpened on universal grinding machines. Owing to frequent sharpening it is sometimes necessary to raise them slightly by putting shims of sheet steel under the dies. These shims are drilled and filed out to conform to the holes in the dies, in order that the scrap punchings may drop through.

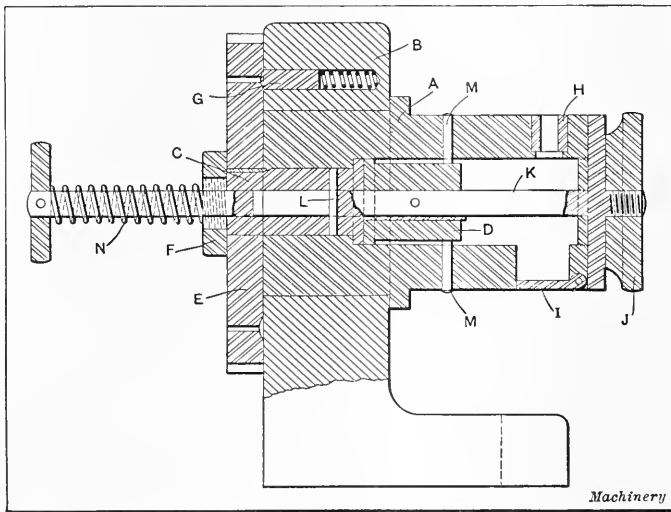

Fig. 14. Type of Die Used for the Spiral Perforating Operation

**Spiral Perforating.** — The die shown in Fig. 14 was designed to perforate shells similar to the one shown in Fig. 15, having holes extending along a spiral. It will be seen that the tool consists of a die-holder *A*, which is carried by the die-bed *B*. This die-holder is counterbored to receive the mandrel *C* and cam *D* which control the movement of the shell to obtain the desired location for the holes. An index ratchet *E* is keyed to the left-hand end of the mandrel and held in position by a nut *F* which holds it against the die-bed. This ratchet is operated by a pawl carried by the ram of the press. In order to

take up any backlash and secure accurate indexing, a spring pin *G* is provided. This pin enters counterbored holes in the ratchet, which are properly spaced to locate the holes in the desired positions in the shell; when the ratchet is moved on to the next station, the pin is forced back into the die-bed and then enters the next hole in the ratchet.

The piercing die *H* is driven into the die-holder and the piercings are held inside the drum, until all of the holes have been

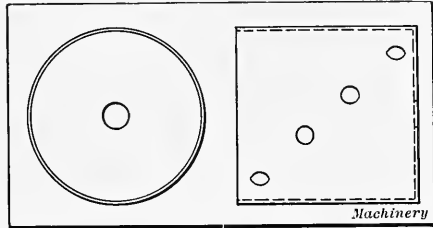

Fig. 15. Shell having Spiral Perforations

punched, by means of a trap door *I*. The shell is held in position by nut *J* carried at the right-hand end of the shaft *K*. Cam *D*, which controls the movement of the shell, is secured to the shaft *K* by means of a key and pin. (This cam is shown in detail in Fig. 16.) Four pins *M* extend into the bore of the

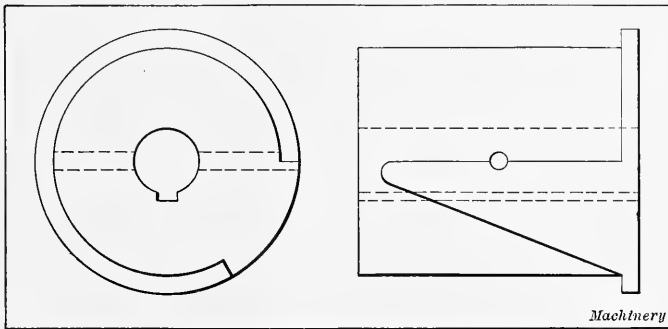

Fig. 16. Cam Used on Spiral Perforating Die

die-holder and these pins are engaged successively by the cam *D*. The left-hand hole of a series is first pierced; the ratchet then rotates the shell and the action of the cam moves it to the right. The indexing is effected as previously described, one hole being pierced at each station. After the four holes on one spiral have been pierced and the ratchet starts to index for the next hole, the pin *M* slips over the point of the cam and the tension of the spring *N* then returns the cam and the work to

the extreme left where the cam is engaged by the next one of the pins *M*. This process is repeated four times to complete piercing the holes on the four spirals in the shell. The longitudinal movement of the shell is limited by the pin *L* which fits in a slot in the shaft *K*. This die proved very satisfactory for this perforating operation.

**Tools for Clipping and Perforating Brass Shells.** — Several interesting forms of press tools for performing clipping and piercing operations on brass shells are described in the following. Fig. 17 shows the shell *A* which is to be clipped along the dotted line, and at *B* and *C* two views of the completed shell are shown. The die used for this clipping operation is illustrated in Fig. 18. The die *A*, over which the shell slips, is a hardened steel collar

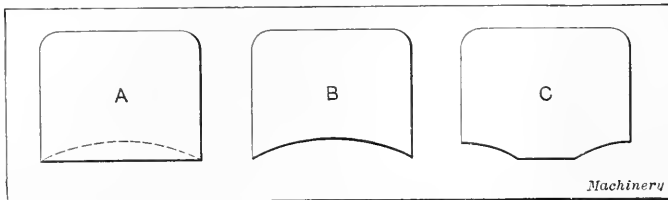

Fig. 17. Shell *A* to be Clipped along Dotted Line, and Two Views of Clipped Shell

which is made to fit the shell accurately. This die is driven onto the stud *B* and held in place by means of the dowel-pin *C*. The stud *B* is a press fit in the die-bed and is prevented from turning by means of the key *D* which serves the additional purpose of locating the stud in the desired position.

The clipping punches *E* are mounted on two dovetailed slides in the die-bed. This construction will be readily understood by referring to the cross-sectional view of the die-bed along the line *X-X*. Allowance is made for any adjustment of the punches that may be necessary on account of grinding by the provision of elongated holes for the screws which secure the punches to the slides. In case any adjustment is made, a shim of sheet steel of the required thickness is placed between the back of the punch and the slide. This gives the punch a bearing on the slide and relieves the screws from the pressure of the cut. The punches are made to conform accurately to the cutting edge of

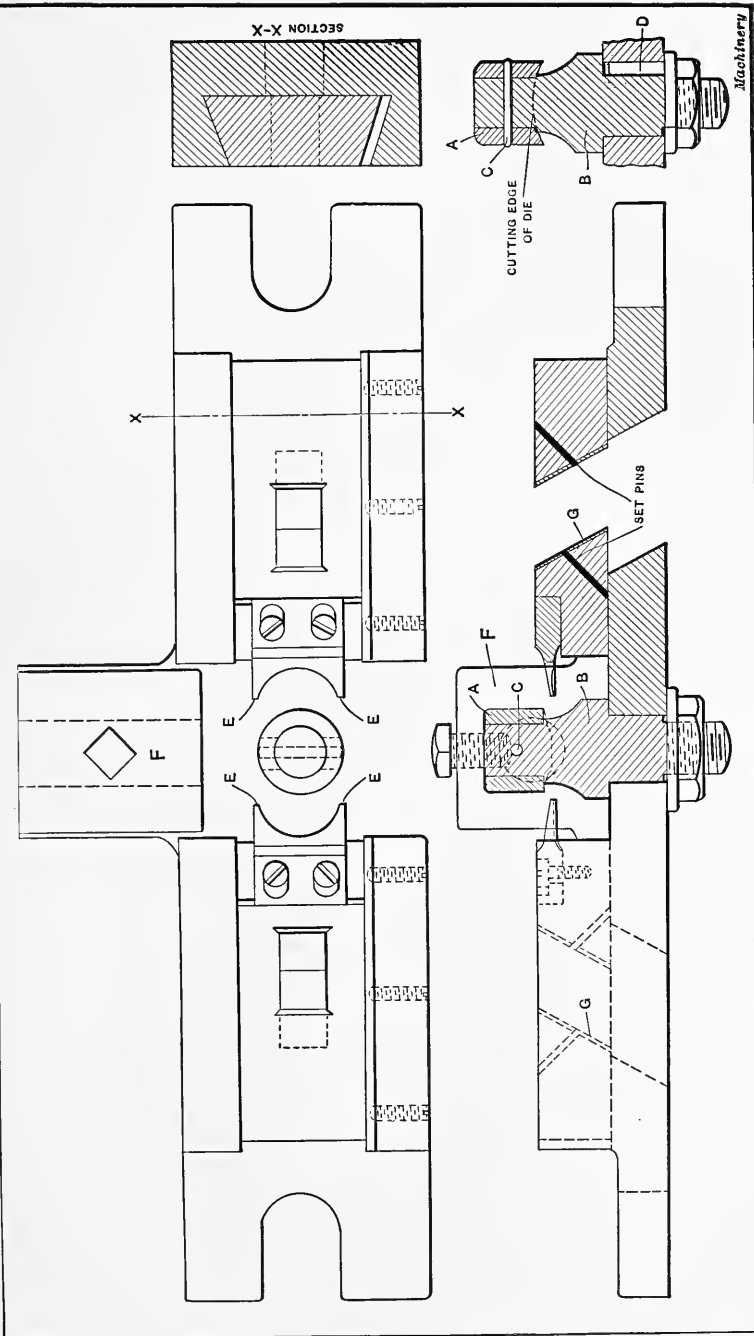

Fig. 18. Die-bed Equipped with Tools for Clipping Shell shown in Fig. 17

the clipping die. The faces of the clipping punches conform to the circumference of the shell and the points *E* cut a little in advance of the remainder of the punch in order to insure having the shell clipped without leaving a fin or burr of any kind.

In order to clip a shell with this set of tools, the work is placed over the die and the press is then tripped. The punch shown in Fig. 10 is held in the ram by means of the shank *A*. When the ram descends, the inner surfaces *B* of the arms, which are inclined at 30 degrees, come in contact with the steel pads *G*, Fig. 18, in the slides that carry the clipping punches and move

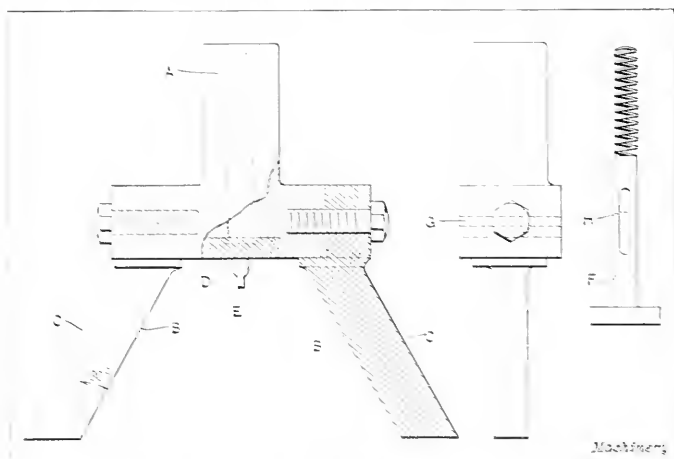

Fig. 10. Punch-holder with 30-degree Arms to Control the Movement of the Slides

them in toward the die. This brings the clipping punches into action and causes the shell to be clipped. When the ram starts its return stroke, the outer surfaces *C* of the arms on the punch cause the slides which carry the clipping punches to be returned to their original positions. It will be obvious that this method of actuating the slides is positive in action and does away with the use of springs for returning the slides. It will be seen that the punch-holder *D*, shown in Fig. 10, has a small piercing punch *E* mounted in it. This piercing punch is used in an operation that will be described later. When the tool is used for the clipping operation, the piercing punch *E* and the punch-holder *D* are removed from the punch and the "hold-

down" *F* is mounted in their place. This hold-down is held in place by means of a pin *G* which fits in the slot *H*, the length of the slot being sufficient to allow the hold-down the necessary amount of movement. This hold-down moves a little ahead of the clipping punches and thus comes into contact with the top of the shell and holds it securely in place so that it cannot be raised off the die when the clipping punches begin to cut.

**Construction of the Die-bed.** — The shells that are clipped or pierced on the die-bed shown in Fig. 18 are ordered in lots of not over 25,000. This fact made it desirable to make a die-bed

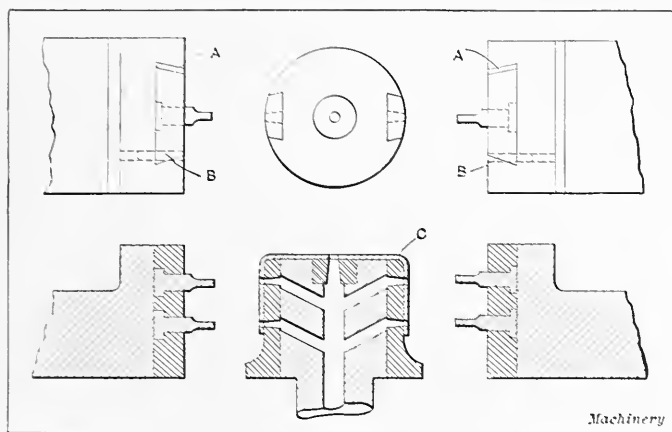

Fig. 20. Die Set up for Piercing Shell held in Vertical Position

that could be used for both clipping and piercing operations, and this advantage is obtained by the design shown. This would not be of much advantage, however, if the work had been ordered in large quantities which would require the same set of tools to work day after day. In some cases, it was found desirable to provide special slides for a given set of punches, and the clipping punches shown in place on the die-bed in Fig. 18 are an example of this kind. When these punches are removed, the slides are taken off with them and the regular slides can then be put in place on the die-bed in order to allow other tools to be set up. It will be seen that gibs are provided to enable any wear which may develop in the slides to be taken up.

The construction of the die-bed is such that shells can be held

in either a horizontal or vertical position. This will be better understood by referring to Figs. 20 and 21 which show shells mounted in the vertical and horizontal positions. The shell *C*, which is shown in position on the die in Fig. 20, has five holes pierced in it. Two of these holes are pierced in either side of the shell by means of piercing punches carried in the slides of the die-bed, while the fifth hole is pierced in the top of the shell by means of the piercing punch *E*, which is shown in position in the punch-holder in Fig. 19. The piercing punches for working on the sides of the shell are mounted in regular slides of the

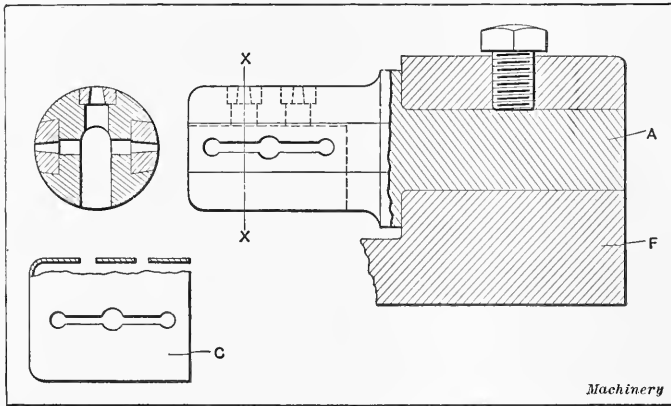

Fig. 21. Die Set up for Piercing Shell held in Horizontal Position

die-bed shown in Fig. 18. Referring to the top view in Fig. 20, it will be seen that these punches are mounted in dovetail holders which are held in the desired position by means of keys *A*. The pins *B* locate the punches in their proper positions and are particularly convenient in obtaining the desired alignment when setting up the tools after they have been removed for sharpening.

Fig. 21 not only shows the construction of the piercing die for piercing the shell *C* (shown at the left-hand side of the illustration) but also illustrates the way in which the work is held in a horizontal position in the same die-bed that is used for holding work in a vertical position. Referring again to the illustration, Fig. 18, it will be seen that the part *F* at the back of the die-bed has a hole in it to receive the shank *A* of the piercing die-



holder which is held in place by means of a set-screw. The shell *C* which is pierced on this die could be pierced in a vertical position but this would necessitate a three-slide die-bed. With the method now in use, the slot at either side of the shell is pierced by punches carried in the slides of the die-bed and the two small holes at the top of the shell are pierced by two punches carried in the punch-holder mounted in the ram of the press. In the case of the die used for piercing this shell, and all of the other dies referred to, it will be seen that a space is provided to allow the scrap and dirt to drop out at the bottom of the die.

## CHAPTER IX

### THE MULTIPLE PLUNGER PRESS AND ITS TOOLS

The multiple plunger press is designed for producing, by means of a series of simultaneous operations, a complete article at every revolution of the press. It is constructed in various styles and sizes, the number of plungers ranging anywhere from three to eight. The most common type, however, and that most extensively used for the general run of small work, is the one shown in Fig. 1, which is a six-plunger machine. This machine can be used for such operations as blanking, cupping, piercing, forming, embossing, stamping, curling, bending, lettering, perforating, clipping, etc., and in fact almost any light operation that is performed on sheet metal. Of course this machine can be used when only three or more operations are required, by having the remaining plungers run idle.

The machine is driven by tight and loose pulleys, as shown to the left of the illustration, and is back-geared; the ratio of the gearing is  $4\frac{1}{2}$  to 1, the larger gear shown guarded to the left being on the upper camshaft. This camshaft *S* is made from a crucible steel forging, while the cams held on it are made of tool steel and hardened. In addition to operating the plungers, this camshaft, through the gearing shown at *G*, operates the roll feed, the reel used for holding the metal being shown at *H*. The upper camshaft *S* also drives, through bevel gears, the vertical crankshaft *I*, which actuates the transfer slide and the lower camshaft *S*<sub>1</sub>. The plungers *A*, *B*, *C*, *D*, *E*, and *F* are made from tool steel of square section, and work in scraped bearings. The lower ends of the plungers *B*, *C*, *D*, *E*, and *F* are tapped out to receive the punch-holders, which are threaded into them. The blanking plunger *A* is bored out to receive a tapered split bushing into which the blanking punch is driven. The lower part of this split bushing is made square, so that, by turning it around

with a wrench, it can be removed and the blanking punch driven out. The blanking punch can also be made to fit directly into the plunger, if so desired.

The blanking plunger *A* is set one-half revolution in advance of the other plungers, so that the blank, after it is cut, is carried

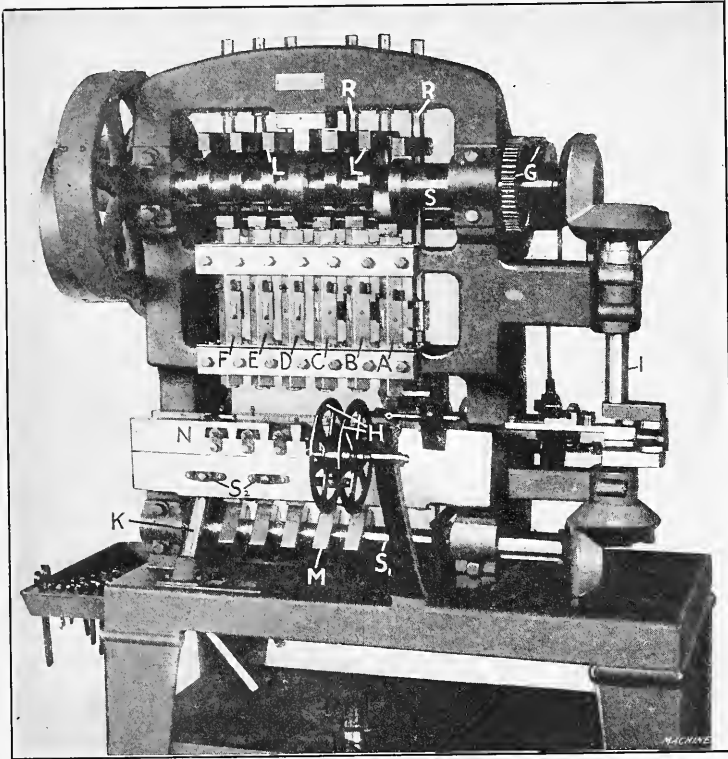

Fig. 1. Multiple Plunger Press

by the transfer slide over the first cupping die before the plunger *B* descends. This is accomplished by changing the position of the cam controlling the operation of the blanking plunger on the upper camshaft *S* in relation to the other cams. The plungers are operated by horizontal "lifters" *L*, one lifter being provided for each plunger. These lifters are clamped to round rods *R* located at the rear of the press, and knee pieces connecting these rods to the plungers effect their operation. The

usual form of wedge adjustment is provided for increasing the pressure of the plungers, the adjustment being effected by means of wedges which lower or raise the "bumpers" as desired.

The lower camshaft  $S_1$  is provided with five cams  $M$  as shown, these being split and held to the shaft by screws, so that they may be shifted around on the camshaft to the position desired and then clamped. These cams operate the knock-up plungers into which are lightly driven the ejecting-pins used in removing the work from the dies. The work is carried from one die to the other by means of a transfer slide actuated by the vertical crankshaft  $I$ .

**Transfer Slide and Auxiliary Mechanism.** — The transfer slide, or "carrier" as it is sometimes called, is made of tool steel, and is a sliding fit in the die-bed  $N$ . This slide holds the fingers, which are used for carrying the work from one die to the other, and also holds the nest or set-edge used in carrying the blank from the plunger  $A$  to plunger  $B$ , where the blank is cupped. A clear idea of the construction of a transfer slide, fingers, and dies can be obtained by referring to Fig. 2, where a plan of the slide and a sectional elevation of the dies and punches for producing a one-piece collar button are shown. The set-edge or nest is shown at  $A$  with the blank located in it. This nest may be removed and others substituted to suit the shape of the blank. It is cut out as shown, so that it will clear the first cupping punch when the slide recedes.

The fingers  $B$ ,  $C$ ,  $D$ ,  $E$ , and  $F$ , respectively, which are patented, are held in the transfer slide in smooth cylindrical bearings, the ends of the fingers being fitted into these bearings and held in place by screws  $G$  as shown. Each pair of fingers is actuated by coil springs  $H$ , which give them the desired tension on the blank, these springs being held in place by short pins driven into the fingers, and screws  $I$  located in the slide. The fingers are rounded at  $J$ , so that they will readily open when the slide recedes and the fingers slide past the punches. They are also rounded at the top and bottom as shown in Fig. 3, so that they will swing out of the way when they come in contact with the punch on the down-stroke or with the shell on the up-stroke.

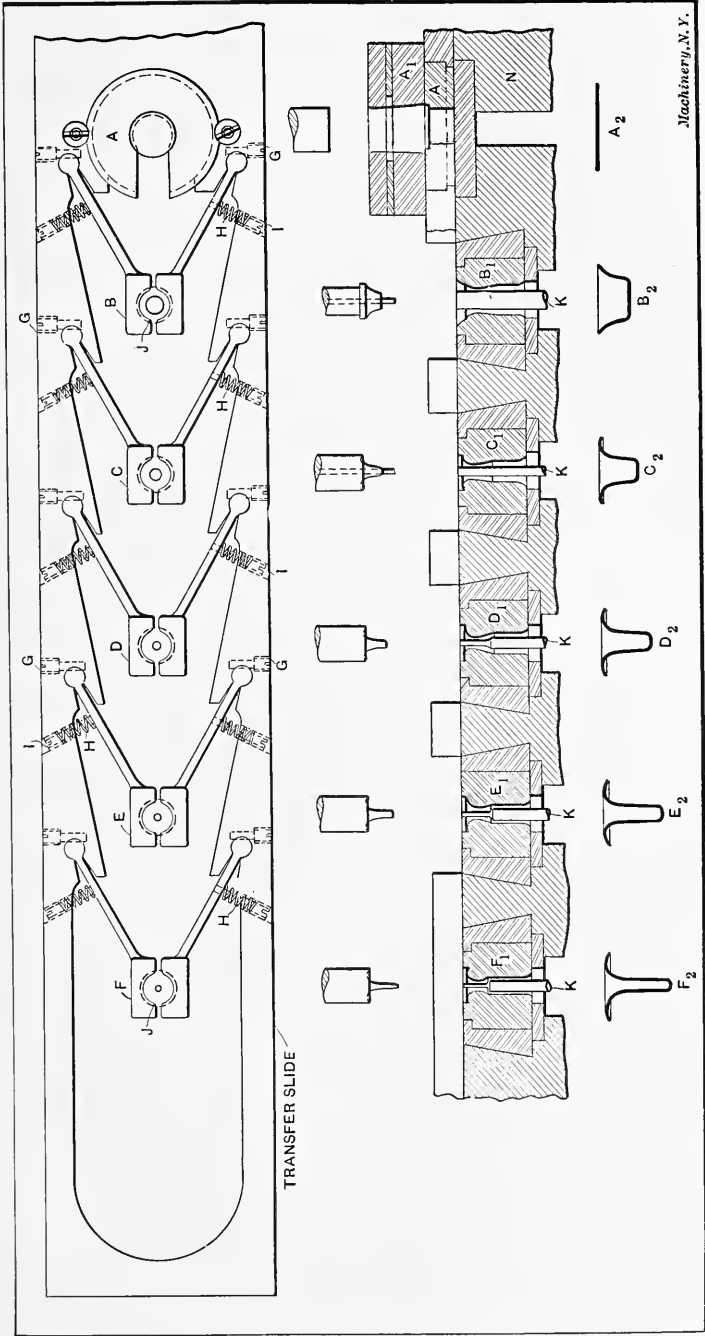

Fig. 2. Diagram Illustrating the Construction of the Transfer Slide, Ejecting-pins, and Dies, and also the Successive Operations on a One-piece Collar Button

The blanking die  $A_1$  is of rectangular section and is fastened by cap-screws and dowels (not shown) to the die-bed  $N$ , Fig. 2. The stock is placed on the reel  $H$  (see Fig. 1) and passes over a

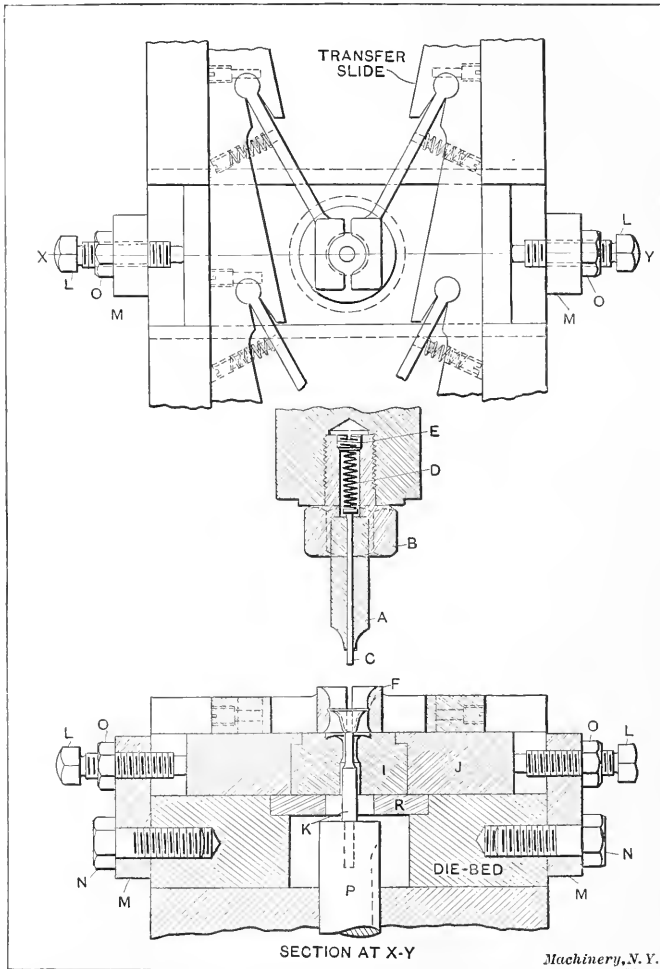

Fig. 3. Illustration Showing the Construction of the Punches and Dies and the Manner in which they are Held

lubricating sponge-box, and from there over the top of the blanking die in the usual manner. A pair of ratchet rolls located at the rear of the press and operated by the gears  $G$  on the upper camshaft  $S$  draws the stock over the die, after which it is wound

into compact form on a scrap-reel, also located at the rear of the press. The blanking punch forces the blank, after it has been cut, through the die and locates it in the nest *A*. After the blanking punch comes out of the nest *A*, the transfer slide advances, carrying the blank, and locates it over the cupping die *B*<sub>1</sub>, when the punch forces it out of the nest into the die. The blank, after being operated on, is removed from the dies by ejectors *K* which, in turn, are actuated by the cams *M* on the lower camshaft *S*<sub>1</sub> (see Figs. 1 and 4). The ejecting-pins *K* which are lightly driven into the knock-up plungers, when not being forced down by the punches, are retained flush with the top face of the dies, by means of flat springs *S*<sub>2</sub>, which are shown

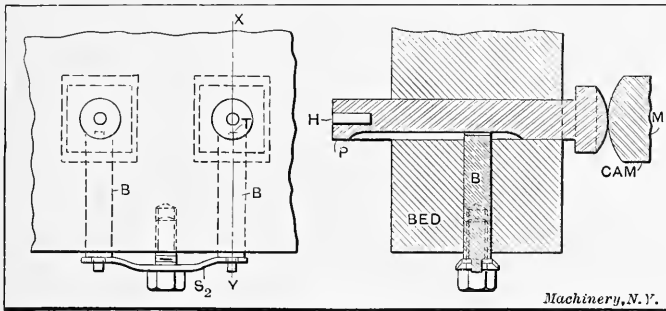

Fig. 4. The Knock-up Plunger and the Method of Operating and Retaining it

in Fig. 1 and in detail in Fig. 4. These springs fit over bronze plugs *B*, which bear against the knock-up plungers *P*. The bronze plugs *B* are provided with a teat *T* which fits in a slot cut in the plunger, thus preventing them from turning. The springs are held in position by cap-screws, and are provided with elongated holes, which fit over the reduced ends of the bronze plugs. The knock-up plungers are of square section on the lower end, and rounded so that they work freely on the lifting cams *M*. A hole *H* is drilled in the top of the plungers into which the ejecting-pins are lightly driven.

**Operation of the Transfer Slide.** — In operation, as the stock is drawn by the feed-rolls over the blanking die, it is blanked, and the blank is forced through the blanking die *A*<sub>1</sub> into the nest *A*, Fig. 2. When in this position the transfer slide advances,

and carries the blank from the die  $A_1$  to the cupping die  $B_1$ . Here the slide dwells until the cupping punch descends and forces the blank through the nest  $A$  into the die. The transfer slide now retreats before the punch has ascended out of the die, and for this reason it is necessary to cut out the nest as shown, so that it will slip by the punch. When necessary, the punch is reduced in diameter just above the working part in order that the nest can slip past it. On the up-stroke of the plunger  $B$  (see Fig. 1), the ejecting-pin  $K$ , Fig. 2, which is held in the knock-up plunger  $P$ , Fig. 4, forces the cup out of the die  $B_1$  into the fingers  $B$ ; then, as the slide again advances, the finger  $B$  carries the cup to the die  $C_1$ , this order of operation being continued in a similar manner until the fingers  $F$  carry the finished piece to the last die  $F_1$ , after which it is forced out of the fingers and passes out of the chute  $K$  (Fig. 1) into a box. It can therefore be seen that the work is at all times under perfect control, the ejecting-pin  $K$  and the fingers working in unison.

After the work has been operated upon for the last time by the punch in plunger  $F$ , and when the operation is a clipping or redrawing operation, the work readily drops into a box; otherwise, if some other operation is to be performed, the work is ejected by means of compressed air or some other simple ejecting device or fixture. The successive operations on the one-piece collar button are shown directly under the dies for producing them in Fig. 2, the operations being designated by the letters  $A_2$  to  $F_2$ , inclusive.

**Method of Holding the Punches and Dies.** — As previously stated, the cupping and stripping punches are held in punch-holders, which are screwed into threaded holes in the plungers. This is more clearly shown in Fig. 3, where the punch is shown held in the manner referred to. The punch shown here is the one located in plunger  $C$ , Fig. 1, and is used for performing the operation  $C_2$  on the collar button shown in Fig. 2. The punch  $A$  (Fig. 3) is made of the desired shape and is driven into the holder  $B$ , this holder being provided with an octagon head and threaded on the upper end so that it can be screwed into the



plunger. A push-pin *C*, for the punch *A*, is operated by a coil spring *D*, which is retained in the holder *B* by a headless screw *E*. This push-pin, however, is not used on all of the punches, other types of stripping fixtures being employed. For this class of work, the fingers are shaped as shown at *F*, so that they hold the cup by the flange alone, not touching the body of the cup at all. This holds the cup effectively, as the ejector-pin *K* is always in the up-position, except when being forced down by the punch *A*, thus additionally supporting the cup while in the finger and preventing it from tipping. The manner in which the ejecting-pin *K* is held in the knock-up plunger *P* is also clearly shown in this illustration.

The die *I* is driven into a tool-steel die-holder *J*, this holder being counterbored as shown, so that the die fits up against the shoulder, preventing it from being drawn out. The die *I* rests on a hardened tool-steel washer *R* located in the die-bed, and which resists the thrust of the punches. The die-holder *J* is fitted in a dovetailed groove formed in the die-bed, and is retained in the desired position by means of set-screws *L* located in blocks *M*, which are held to the die-bed by means of cap-screws *N*. The set-screws *L* are provided with lock-nuts *O*, which lock the screws in the desired position.

These machines work so successfully that they require very little attention. In fact, they will sometimes run for weeks at a time without requiring any special attention beyond that of oiling, starting in a new coil of metal, and occasionally sharpening and polishing the punches and dies.

**Tools for Multiple Plunger Presses.** — The multiple plunger press has become a most important factor in the economical manufacture of articles from sheet metal, and this type of press is now used for both large and small work; the presses for the large sizes of work are necessarily of stronger and more massive construction than those used for smaller work. The tools illustrated and described in the following are used for the smaller classes of work.

Before going into details concerning the construction of the punches and dies used in multiple plunger presses, it may be well

to lay stress upon the fact that, preparatory to constructing the tools, one of the first things to do is to make sure that the construction of the press is such that the tools will not only be interchangeable in a given press, but also with the tools in other presses. In trying out a new set of tools, it is often found that better results are obtained by changing the sequence of some of the operations; for instance, if plunger No. 2 does the cupping, No. 3 the forming, No. 4 the piercing, etc., it often happens that some of these operations must be reversed, and if the tools are interchangeable, this can be done without any extra time being spent in altering the length of the punches, or in making new ejecting-pins to fit the press. Moreover, if the tools for different presses are not interchangeable, they can only be set up and run in the press for which they were originally made; this means that some of these presses may frequently be out of use, simply because there are no orders for work which calls for the use of the tools that were made for the "dead" machine in question. On the other hand, there may be orders for work which must necessarily wait until another job has been run through on a given press that is in use, because the tools to be used were made for the press that is already in use, and are not interchangeable. This deplorable condition actually exists in some shops. The fact must be taken into consideration that the taper wedges used for adjusting the stroke of the plungers affords only  $\frac{3}{16}$  inch adjustment, and unless the presses are made so that the tools are interchangeable, the loss of time due to having "dead" machines is bound to occur again and again.

In adjusting a multiple plunger press to insure interchangeability, the first thing to do is to regulate the taper wedges used for adjusting the stroke of the plungers, so that they will all be in the same relation to each other. The press is then given a half turn, so that all the plungers except plunger No. 1 are down as far as they will go, so that the distance from the top of the die-bed to the face of the respective plungers can readily be measured. It seems hardly necessary to say that this distance must measure the same in each case. The same can also be said of the face of the knock-up plungers which, when raised

up as far as they will go, must all measure the same distance to the top of the die-bed. The depth of the ejecting-pin holes in these plungers must also be the same, as, on small work, the ejecting-pins rest on the bottom of these holes; and it is therefore essential that the depth of the respective holes be the same if the ejecting-pins are to be interchangeable. It is also important to have the holes for the dies in the dovetail die-holder perfectly central with the threaded holes in the plungers, and also bored out to fit plug standards, so that there will be interchangeability so far as the various dies and die-holders are concerned.

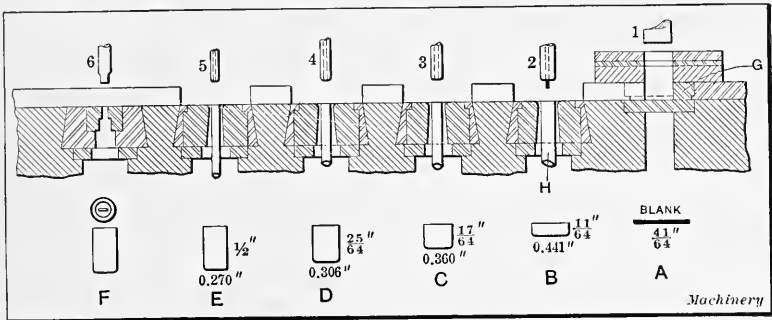

Fig. 5. Construction of Punches and Dies and Successive Operations in Drawing and Piercing Shell F

**Examples of Shell Work done on Multiple Plunger Press.** — Fig. 5 shows a set of tools for a six-plunger press used in making the shell which is shown completed at *F*. The diameter of this shell is 0.270 inch, the length is  $\frac{1}{2}$  inch, and it has a small elongated slot pierced out of the bottom. The metal is first fed between the guide plates, where the round blank *A* is punched out and forced into the nest *G* in the transfer slide by the blanking punch in plunger No. 1; the nest is made to fit the blank tight enough to retain it. The blank is then carried under the drawing punch held in plunger No. 2 and drawn up into the shell shown at *B*. The punch is made small enough so that it will just draw up the shell and keep it from wrinkling, thereby preventing the metal from becoming too hard to be successfully worked in the following operations. After the shell is drawn up, it is ejected from the die by the ejecting-pin *H* and then forced between the fingers in the transfer slide. These fingers

hold the shell in place while it is being carried under plunger No. 3. As the shell *B* does not hug the punch tightly, no stripper is necessary; the push-pin prevents the shell from clinging to the punch. When the shell *B* comes under plunger No. 3, it is redrawn to the shape and size shown at *C*, care being taken to have the redrawing punch small enough so that it will not pinch the metal any harder than is absolutely necessary. The same can also be said with reference to the following drawing operations, except the one done under plunger No. 5, which draws

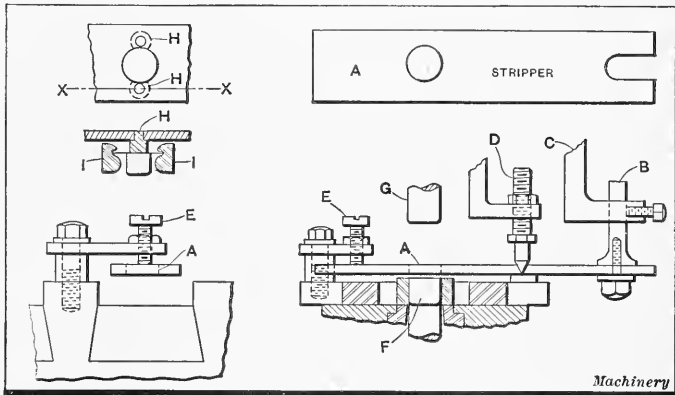

Fig. 6. Stationary Stripper and Method of Securing it to the Press

the shell *E* hard. The last operation is piercing out the narrow slot in the bottom of the shell, which is done by the piercing punch held in plunger No. 6 and the piercing die shown directly underneath it. The finished shell is then pushed from the press into a pan or box by a push-finger held in the transfer slide. It will be seen that no ejecting-pin is used in this operation, as the shell rests on the top of the piercing die while being pierced, and therefore the knock-up plunger can be removed in order to allow the scrap punchings to escape. In stripping the shell from the punches in the third, fourth, fifth, and sixth operations, stationary strippers similar to the one shown in Fig. 6 are used.

**Stripping the Work from the Punches.** — For the punches and dies used in a multiple plunger press, two forms of strippers are generally used. One of these strippers is known as the stationary stripper, while the other is called a traveling stripper and is

used in connection with a thimble for stripping the work from the punches. Fig. 6 shows the stationary stripper *A* held in position by the stud *B*, which, in turn, is held by a bracket *C* fastened to the rear of the press. The stripper has an elongated slot in one end to provide for adjustment. In addition to the stud *B*, the stripper is supported by the pointed screw *D* and the screw *E*, which are placed on each side of the hole used for stripping the shell *F* from the punch *G*. These screws, as well as the stud *B*, can be adjusted to different heights to accommo-

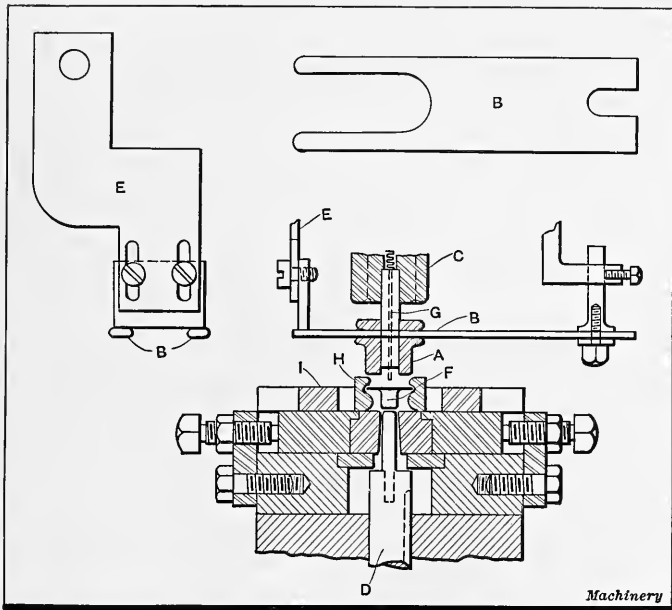

Fig. 7. Illustration Showing Use of a Traveling Stripper on a Multiple Plunger Press

date different lengths of shells. The pointed end of the screw *D* rests in a small countersunk hole in the stripper; this not only helps to stiffen the stripper but also tends to prevent it from shifting endways. Fig. 6 illustrates the manner in which the stripper strips the shell shown directly underneath it. The device used for stripping flanged shells from the punch with a stationary stripper is shown in the upper left-hand view. Two short shouldered pins *H* strip the work from the punch, so that

the flanged part of the shell can be readily grasped and retained in the circular grooves in the fingers *I*, as shown. These pins are made small and placed in the center of the open space between the fingers so that the projecting pins will clear the fingers and not interfere with their free action. The sectional view of this stripper is on the line *X-X*.

Fig. 7 shows the manner in which a traveling stripper is used in the multiple plunger press for stripping the work from the punches. The punch is made a sliding fit in the stripping

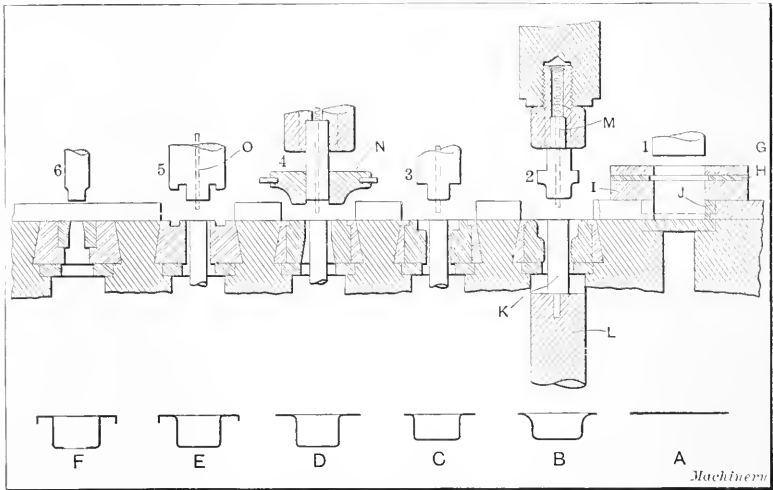

Fig. 8. Example of Flanged Work Formed on Six-plunger Press

thimble *A*, which has a circular groove that engages in the forked part of the traveling stripper *B*; this thimble is also used in forming up flanged shells, as the face of the punch-holder *C* forces the thimble down on the flange and keeps it flat, thus preventing the work from getting out of shape. Making use of the stripper thimble in this manner does away with the necessity of using a solid shouldered punch; and as these thimbles can be used over and over again, they effect quite a saving. When in operation, the thimble is forced downward by the punch-holder; on the upward stroke of the press the traveling stripper, which acts in the capacity of a flat spring, forces the thimble upward with the assistance of the knock-up plunger *D*. When

the fork of the stripper comes in contact with the adjustable stop *E*, as shown, it affords a substantial stripping arrangement for stripping the shell *F* from the punch. The stop *E* is fastened to the front of the press, and is made adjustable to allow for different lengths of shells, in order that the shells can be stripped from the punches at the right time on the upward stroke of the press. The punch is made slightly tapering so that the shells can be readily pushed off by the push-pin *G* and grasped by the fingers *H* in the transfer slide *I*.

**Examples of Flanged Shell Work.** — Another interesting example of shell work, as performed on the multiple plunger press, is shown in Fig. 8. These tools complete the shell shown at *F* in six operations, their construction and operation being somewhat similar to the tools described in connection with Fig. 5. The metal is fed under stripper *G* in the usual way, and guided by the plates *H*; *I* is the blanking die and *J* the nest in the transfer slide for carrying the blank under plunger No. 2, where it is forced into the die and cupped up as shown at *B*. In this operation no blank-holder is used to prevent the blank from puckering while it is being drawn up. On the downward stroke of the press, the cupping punch forces the blank and the ejecting-pin *K* downward. As the knockout plunger *L* which holds the ejecting-pin in place is held up by spring tension, the blank is prevented from shifting and is held central while being cupped up. The blank is first partly cupped by the round corners shown on the top of the die, after which it is drawn up into the desired shape by the lower shoulders on the die. On the upward stroke of the press, the ejecting-pin forces the cupped shell out of the die into the fingers of the transfer slide. No stripper is required, as the metal is not pinched hard by the punch, and the shell therefore does not hug the punch. The push-pin *M* merely prevents the shell from clinging to the punch on account of any settlement of oil in the bottom of the shell. In cupping up the shell in the manner previously described, it should be stated that a clean cut blank must be used which is free from all burrs, as otherwise the shell will pucker and wrinkle while being drawn into shape, inasmuch as no blank-holder is used.

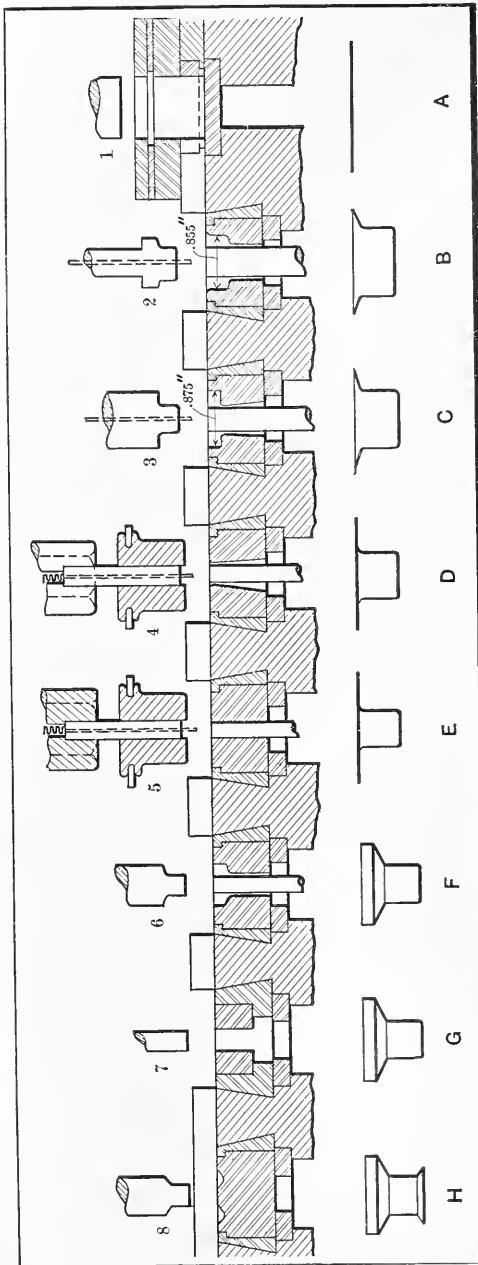

Fig. 9. Construction of Tools Used to Form Shell H on Eight-plunger Press

After the shell is cupped, it is transferred under punch No. 3, where it is drawn up and flanged as shown at C. Punch No. 4, with the aid of the thimble *N*, draws the barrel part of the shell smaller and longer, as shown at D, while punch No. 5 acts upon the flanged part of the shell only, and forms it into the shape shown at E. The teat of this punch is made a sliding fit in the barrel part of the shell and guides it into the die. As the shell does not hug the punch, no stripper is necessary; the push-pin *O* prevents the shell from remaining on the punch. The last operation is to pierce out the  $\frac{1}{4}$ -inch hole in the shell bottom, shown at F; this is done by punch No. 6, after which the finished shell is



stripped from the piercing punch by a stationary stripper. The work is then either blown out of the way by compressed air, or pushed off the press by a push-finger, and drops into a box under the press.

**Example of Shell Work on Eight-plunger Press.** — Fig. 9 shows a most interesting set of tools for making the shell shown at *H* complete from sheet metal on an eight-plunger press. The tools shown are made and operated in the same manner as those already described and therefore require very little explanation. The illustrations show the progress of each operation very clearly, as the shell is carried from one punch to the other. The blank *A* is cut from the metal, carried under punch No. 2, and cupped up in the usual way. The cupped shell *B* is then transferred and gradually drawn up into a flanged shell as shown at *C*, *D*, and *E*. In drawing up the shell to the form shown at *D* and *E*, the usual stripping thimbles are used in connection with traveling strippers. On the next operation, punch No. 6 cups the flanged part of the shell into the shape shown at *F*. The teat of punch No. 6 next engages the inside of the shell and forces it into the die. As the shell is drawn into the die, the flanged part is cupped up while being drawn over the corner of the die which is slightly rounded, after which it is formed into the desired shape by the beveled shoulder of the die. Punch No. 7 pierces the bottom of the shell; the shell is then stripped from the punch by the stationary stripper. On the last operation, the bottom end of the shell is flared outward, as shown at *H*, by being forced over the short tapered teat shown in the center of the die. The shell is then stripped from the punch and drops into a box under the press.



## INDEX

	PAGE
<b>A</b> ir blast, use of, for ejecting press work . . . . .	284
Air pockets in dies, formation of . . . . .	130
"Alligator skin" effect on drawn parts . . . . .	186
Angle of redrawing die, drawing edge . . . . .	119
Angular clearance for dies . . . . .	51
Annealing dies, value of . . . . .	27
Annealing drawn shells . . . . .	133
Armature disks, making sectional dies for . . . . .	258
Automatic press feeding mechanisms . . . . .	265-282
Automatic release for feed-rolls . . . . .	267
<b>B</b> aths for cooling dies when hardening . . . . .	69
Bending and twisting die, combination . . . . .	200
Bending dies . . . . .	19, 188
compound type . . . . .	190, 201
for forming staples . . . . .	197
for making five bends . . . . .	194
for making four bends . . . . .	192
simple types of . . . . .	188
Blank diameters, determining, for drawn work . . . . .	121-130
formulas for drawn shells . . . . .	127-129
table of, for cylindrical shells . . . . .	125
Blanked holes, amount of stock between . . . . .	94
Blank-holder, arranged to prevent excessive flange pressure . . . . .	167
hand-operated type, for single-action press . . . . .	164
of double-action die . . . . .	15
of inside type for redrawing die . . . . .	18
pressure compensating attachment for . . . . .	165
Blanking and piercing dies, examples of . . . . .	103
Blanking and shaving dies, combination . . . . .	106
Blanking die, laying out . . . . .	27
location of stop-pin . . . . .	94
machining opening in . . . . .	39
of plain type . . . . .	2
Blanking die templets . . . . .	36
Blanks, for elliptical shapes . . . . .	178
for rectangular flanged shells . . . . .	177
for rectangular tapering shells . . . . .	177
for rectangular work, shape of . . . . .	174
sub-press die, separating from scrap . . . . .	243

	PAGE
Bolsters or die-beds, types of . . . . .	96-103
Bridge between blanked holes, width of . . . . .	94
Bridge type of stop-pin . . . . .	84
Burnishing before perforating shells . . . . .	288
Burnishing die . . . . .	10
<b>C</b> am-actuated strippers . . . . .	77
Cartridge cases, drawing . . . . .	150
trimming to length . . . . .	157
Chute and hopper feed . . . . .	280
Chute feed for drawing press . . . . .	282
Clamp for diemakers . . . . .	38
Classes of dies . . . . .	1-24
Clearance, angular, for dies . . . . .	51
at corners of rectangular drawing dies . . . . .	171
between punches and dies . . . . .	49
for first-operation drawing die . . . . .	119
Cochrane-Bly filing machine for dies . . . . .	47
Cochrane-Bly universal die shaper . . . . .	43
Combination die, equipped with special blank-holder . . . . .	167
for deep drawing . . . . .	167
pressure compensating attachment . . . . .	165
why used for shallow work . . . . .	110
Combination drawing die . . . . .	13
Compensating attachment, pressure, for blank-holder . . . . .	165
Compound bending dies . . . . .	190-201
Compound blanking dies . . . . .	6
Compound dies, points on making . . . . .	80
Cooling baths for die hardening . . . . .	69
Crab-clamp for diemakers . . . . .	38
Curling dies . . . . .	20, 204
for edges of tin buckets . . . . .	209
for making hinges . . . . .	204
special design for typewriter part . . . . .	209
for small brass covers . . . . .	211
Cyanide of potassium, use of, when hardening . . . . .	184
Cylindrical hub drawn from pierced hole . . . . .	183
<b>D</b> epth of first drawing operation . . . . .	111
Diameter of first drawing die . . . . .	111
Diameter reductions of drawn shells . . . . .	112
Diameters of blanks for drawn work . . . . .	121-130
Die-beds or bolsters, types of . . . . .	96-103
Die diameter for first drawing operation . . . . .	111
Die diameter reductions for redrawing . . . . .	112
Die filing machine, Cochrane-Bly . . . . .	47
Diemakers' adjustable clamp . . . . .	38

	PAGE
Dies, bending, simple types of . . . . .	19, 188
blanking, laying out . . . . .	27
burnishing . . . . .	10
combination drawing . . . . .	13
compound, points on making . . . . .	80
compound type . . . . .	6
correcting mistakes made in machining . . . . .	74
curling . . . . .	20, 204
different classes of . . . . .	1-24
drawing . . . . .	11, 109
drawing, clearance for first-operation . . . . .	119
drawing, for cylindrical shell . . . . .	134
drawing, for spherical covers . . . . .	135
drawing, for tin nozzles . . . . .	137
drawing, shapes of edges . . . . .	115
embossing . . . . .	10, 147
examples of sectional construction . . . . .	244-258
follow, tandem or progressive . . . . .	3
for blanking and piercing, examples of . . . . .	103
formation of air pockets in . . . . .	130
for perforating tapered and irregular shapes . . . . .	294
for washers, laying out . . . . .	33
gang or multiple . . . . .	5
hardening . . . . .	66
hardening, cooling baths for . . . . .	69
hardening, when operation is required . . . . .	74
location of stop-pin . . . . .	94
perforating type . . . . .	7, 287
plain blanking . . . . .	2
reworking worn . . . . .	75
shapes of edges for redrawing . . . . .	118
shaving or trimming . . . . .	8
shear of cutting faces . . . . .	64
sub-press, construction and use of . . . . .	212
sub-press, general methods of constructing . . . . .	226-236
sub-press type and its advantages . . . . .	21, 212
swaging . . . . .	24
types of die-beds or bolsters for . . . . .	96-103
types of stop-pins for . . . . .	81-93
used in multiple plunger presses . . . . .	321
Double-action dies . . . . .	15
Double-roll feeding attachment . . . . .	269
Drawing and forming die construction, miscellaneous points . . . . .	181
Drawing and forming, lubricants for . . . . .	131
Drawing, cause of stock thickening . . . . .	119
formation of wrinkles in . . . . .	114
rectangular, amount of reduction between draws . . . . .	174
rectangular, determining depth for first-operation . . . . .	172

	PAGE
Drawing, rectangular, shape of blank for . . . . .	174
Drawing a brass shrapnel case . . . . .	159
Drawing a cylindrical hub from a pierced hole . . . . .	183
Drawing, blanking, and embossing die . . . . .	147
Drawing cartridge cases . . . . .	150
Drawing deep parts in combination die . . . . .	167
Drawing dies, classes of . . . . .	11-18
clearance for first-operation . . . . .	119
diameter for first-operation . . . . .	111
diameter formulas . . . . .	113
for cylindrical shell . . . . .	134
for flanged taper shell . . . . .	140
for rectangular work . . . . .	164
for spherical covers . . . . .	135
for tin nozzles . . . . .	137
ironing stock in . . . . .	120
length of straight or cylindrical surface . . . . .	182
of indexing type, multiple . . . . .	159
of sub-press type . . . . .	219
radius of drawing edge . . . . .	117
rectangular, determining number of drawing operations . . . . .	172
rectangular, how corners of first and second dies should be laid out . . . . .	173
rectangular, laying out . . . . .	170
rectangular, radius of corner of first-operation die . . . . .	173
rectangular, radius of drawing edge . . . . .	172
rectangular, with inserted corner pieces . . . . .	169
selecting type of . . . . .	109
special, for single-acting press . . . . .	144
Drawing edges for first-operation dies . . . . .	115
Drawing edges for redrawing dies . . . . .	118
Drawing, forming, and blanking die . . . . .	145
Drawing in multiple plunger press . . . . .	323-329
Drawing reductions for successive operations . . . . .	112
Drawn shell, causes of fractured bottom . . . . .	182
<b>E</b> dge of drawn shell, cause of unevenness . . . . .	117
Edges of first-operation drawing dies . . . . .	115
Edges of redrawing dies . . . . .	118
Ejecting press work with air blast . . . . .	284
Elliptical shapes, blanks for drawing . . . . .	178
Embossing, blanking, and drawing die . . . . .	147
Embossing dies . . . . .	10, 147
Emergency dies . . . . .	25
<b>F</b> eed chute for drawing press . . . . .	282
Feeding mechanisms for presses, automatic . . . . .	265-282
Feed-rolls, automatic release for . . . . .	267
Filing blanking dies by hand . . . . .	45

INDEX

335

	PAGE
Filing machine for dies . . . . .	47
Filing perforating die openings . . . . .	302
Fitting punch to die . . . . .	51
Follow die . . . . .	3
equipped with trimming punch . . . . .	108
locating punches in . . . . .	62
Forming and drawing die construction, miscellaneous points . . . . .	181
Forming dies . . . . .	18
method of locating punch relative to . . . . .	185
Formulas for blank diameters . . . . .	127-129
Fractured bottom of drawn shell, causes of . . . . .	182
Friction dial and push feed . . . . .	277
Friction dial and reciprocating feed . . . . .	279
Friction dial feed for press . . . . .	277
<b>G</b> age plates, method of securing, to dies . . . . .	185
Gang die . . . . .	5
Grain of steel, relation of, to bends . . . . .	183
<b>H</b> ardening dies . . . . .	66
cooling baths for . . . . .	69
determining hardening temperature . . . . .	67
drawing temper of . . . . .	71
points on method of heating . . . . .	71
when hardening operation is required . . . . .	74
Hardening punches . . . . .	72
when operation is required . . . . .	74
Heating die, points on . . . . .	71
Hub, cylindrical, drawn from pierced hole . . . . .	183
<b>I</b> nclined press, die-bed for . . . . .	98
Indexing type of drawing die . . . . .	159
Ironing stock in drawing . . . . .	120
Ironing stock in drawing rectangular parts . . . . .	170
<b>K</b> nockout for a punch-press . . . . .	282
<b>L</b> atch type of stop-pin for dies . . . . .	85-92
Laying out a perforating die . . . . .	208
Laying out blanking dies . . . . .	27
Laying out blanking die from templet . . . . .	38
Laying out blanks for elliptical drawing . . . . .	178
Laying out blanks for rectangular drawing . . . . .	174
Laying out washer dies . . . . .	33
Locating punches in follow dies . . . . .	62
Locating punches in punch-holder . . . . .	61
Lubricants for drawing and forming . . . . .	131

	PAGE
<b>M</b> achine steel, use of, for making punches . . . . .	26
Magnetic device for die hardening . . . . .	67
Milling machine for dies, Thurston . . . . .	44
Multiple die . . . . .	5
Multiple drawing die of indexing type . . . . .	159
Multiple plunger press, arrangement of . . . . .	314
examples of flanged work . . . . .	327
example of shell work on . . . . .	321
tools or dies used in . . . . .	321
 <b>P</b> erforating die stripper . . . . .	 305
Perforating dies . . . . .	7, 287
equipped with tools for trimming . . . . .	308
filing the openings . . . . .	302
for cylindrical work . . . . .	287-293
for spiral perforations . . . . .	306
for tapered and irregular shapes . . . . .	294
methods of laying out . . . . .	298
methods of rotating work . . . . .	296
Perforating punches, cause of breakage . . . . .	78
method of making . . . . .	303, 304
Piercing punches, types of . . . . .	58
Pilot on punch, size and shape of . . . . .	78
use of . . . . .	4
Pneumatic press attachment for ejecting work . . . . .	284
Pratt & Whitney vertical die shaper . . . . .	41
Press feeding mechanisms, automatic . . . . .	265-282
Press, mechanically-operated knockout for . . . . .	282
multiple plunger, dies used in . . . . .	321
multiple plunger, example of shell work on . . . . .	321
multiple plunger, stripping work from punches . . . . .	324
multiple plunger, tools for . . . . .	321
multiple plunger type . . . . .	314
Pressure-pads or blank-holders . . . . .	13, 114
Pressure-pads, rubber . . . . .	187
Progressive or follow type of die . . . . .	3
Punches, cause of lateral thrust . . . . .	80
fitting to die . . . . .	51
forming, method of locating . . . . .	185
for perforating die, method of making . . . . .	303
hardening . . . . .	72
hardening, when operation is required . . . . .	74
how stock is stripped from . . . . .	75
locating in follow dies . . . . .	62
locating in punch-holder . . . . .	61
methods of holding . . . . .	53
perforating, cause of breakage . . . . .	78
perforating, method of making . . . . .	304



INDEX

337

	PAGE
Punches, piercing, types of . . . . .	58
points to consider when locating . . . . .	80
shear of cutting faces . . . . .	64
tempering . . . . .	73
trimming, for follow die . . . . .	108
variation in length of multiple . . . . .	79
Punch-holder . . . . .	54
Punch plate . . . . .	54
Punch press, mechanically-operated knockout for . . . . .	282
Punch troubles and remedies . . . . .	78
Push feed for drawing press . . . . .	273
<b>Q</b> uill punches . . . . .	60
<b>R</b> ack-and-pinion double-roll feed . . . . .	270
Radius of drawing die . . . . .	117
Ratchet dial feed, for press . . . . .	273
safety device for . . . . .	275
Ratchet type of roll feeding mechanism . . . . .	265
Rectangular drawing, amount of reduction between draws . . . . .	174
determining depth for first operation . . . . .	172
method of reducing stock thickness . . . . .	170
shape of blank for . . . . .	174
Rectangular drawing dies . . . . .	164
clearance at corners . . . . .	171
determining number of drawing operations . . . . .	171, 172
equipped with inserted corner pieces . . . . .	169
how corners of first and second dies should be laid out . . . . .	173
laying out . . . . .	170
radius of corner of first-operation die . . . . .	173
radius of drawing edge . . . . .	172
Rectangular drawn parts, trimming . . . . .	180
Rectangular flanged shells, blanks for . . . . .	177
Rectangular tapering shells, blanks for . . . . .	177
Redrawing dies . . . . .	17
shapes of edges for . . . . .	118
Reductions in successive drawing operations . . . . .	112
Rubber pressure-pads . . . . .	187
<b>S</b> afety device for ratchet dial feed . . . . .	275
Sectional die construction, examples of . . . . .	244-258
Sectional die, for linotype type-bar plates . . . . .	252
for square washers . . . . .	247
grinding the parts of . . . . .	259
Sectional type of sub-press die . . . . .	223
Shaping and slotting machines for dies . . . . .	41
Shaving and blanking operation combined . . . . .	106

	PAGE
Shaving die . . . . .	8
nest of spring-operated type for . . . . .	240
Shear of punch and die faces . . . . .	64
Shearing punch into die . . . . .	51
Shrapnel case, drawing a brass . . . . .	159
Single-roll feed for punch press . . . . .	205
Slide feeding mechanism for press . . . . .	273
Slotting and shaping machines for dies . . . . .	41
Solder, use of, on punch when fitting . . . . .	52
Spherical cover drawing dies . . . . .	135
Spiral perforating die . . . . .	306
Staple bending die . . . . .	197
Steel, for deep rectangular drawing . . . . .	170
grain of, in relation to bends . . . . .	183
Steel used for dies . . . . .	26
Stock, amount of, between blanked holes . . . . .	94
Stoning a blanking die . . . . .	48
Stop-pin, bridge type . . . . .	84
classes of, for dies . . . . .	81-96
latch form, operated by stock . . . . .	87
plain fixed type . . . . .	82
position of, relative to die opening . . . . .	94
positive heel-and-toe latch type . . . . .	91
side-swing latch type . . . . .	90
simple latch form . . . . .	85
spring-toe latch type . . . . .	80
starting, for follow die . . . . .	93
Stripper attached to punch . . . . .	76
Strippers, cam-actuated type . . . . .	77
Stripper of a perforating die . . . . .	305
Stripper pins for drawing dies . . . . .	159
Stripping blanks that adhere to punches . . . . .	242
Stripping stock from punch . . . . .	75
Stripping stock uniformly, importance of . . . . .	79
Stripping work from punches of multiple plunger press . . . . .	324
Sub-press, amount that punch enters dies . . . . .	23
axial grooves in plunger and barrel . . . . .	226, 229, 236
construction and use of . . . . .	212
construction of the four-post or pillar type . . . . .	237
for drawing shallow cups . . . . .	219
form of large sizes . . . . .	221
general methods of constructing . . . . .	226-236
method of babbiting . . . . .	232-234
sectional construction . . . . .	223
typical construction . . . . .	213
use of, and advantages . . . . .	211, 212
Sub-press die blanks, separating from scrap . . . . .	243
Swaging die . . . . .	24

	PAGE
<b>T</b> andem or follow type of die . . . . .	3
Taper shell drawing . . . . .	140
Temper of die, drawing . . . . .	71
Temperature for die hardening . . . . .	67
Temperature range for hardening . . . . .	68
Tempering punches . . . . .	73
Templet method of laying out die . . . . .	38
Templets for blanking dies . . . . .	36
Thurston undercutting die milling machine . . . . .	44
Transfer slide or carrier of multiple plunger press . . . . .	316
Trimming drawn rectangular parts . . . . .	180
Trimming punch for follow die . . . . .	108
Triple-action dies . . . . .	16
Twisting and bending die, combination . . . . .	200
<b>U</b> ndercutting die milling machine, Thurston . . . . .	44
Universal die shaper, Cochrane-Bly . . . . .	43
<b>V</b> ent holes in dies . . . . .	130
<b>W</b> asher dies, laying out . . . . .	33
Wiring dies for small brass covers . . . . .	211
Worn dies, method of reworking . . . . .	75
Wrinkles, formation of, in drawing . . . . .	114









LIBRARY OF CONGRESS



0 003 324 091 0